



CEIDEN: La Plataforma Tecnológica de I+D de Energía Nuclear de Fisión

CEIDEN-NNL UK

1-2 February 2016

Topic 5: "Waste management and decommissioning"

Carlos Gómez - GNFE

January 2016



engineering



INDEX



- **TOPIC ITEMS**
- **WM & D&D in SPAIN**
- **JOSE CABRERA NPP DECOMMISSIONING STATUS**
- **RESEARCH AND DEVELOPMENT**

January 2016



engineering



Topic 5: Wastes Management & Decommissioning

Participants: EEAA, IDOM, ENSA, GNFEng, CSN, CIEMAT, CSIC-IETcc

Points from NNL presentation taken by CEIDEN:

- ILW/LLW thermal treatment research
- Radionuclide colloid behaviour
- Microbiological and geochemical aspects of Geological Disposal
- Photonics based remote characterisation (Raman spectroscopy)
- C14 in reactor graphite (characterization, decommissioning and disposal)
- Augmented virtual reality design
- Decontamination
- Robotics

Topic 5: Wastes Management & Decommissioning

Additional points from CEIDEN:

- Stored waste Characterisation
- Remote non-destructive waste characterization by tomographic analysis
- Properties of PWR/BWR spent fuel after several decades at dry storage conditions (ATC)
- Spent fuel behaviour in different storage condition (experimental/modelling).
- Evolution of failed fuel pins from discharge to disposal
- Aging Management and D&D.
- Low doses and Radiation Protection
- Future of Materials for neutron shielding, absorbers...
- Engineering Barriers for Geological Disposal
- Land Quality
- Education and Training opportunities WM & D&D

INDEX



- TOPIC ITEMS
- **WM & D&D in SPAIN**
- JOSE CABRERA NPP DECOMMISSIONING STATUS
- RESEARCH AND DEVELOPMENT

January 2016



engineering



WM & D&D in SPAIN



□ BOUNDARY CONDITIONS OF THE DECOMMISSIONING IN SPAIN

- During dismantling the license is transferred
- Regulatory framework for decommissioning
- Waste disposal available
- Decommissioning fundings
- Companies involvement
- Public involvement



WM & D&D in SPAIN



□ BOUNDARY CONDITIONS OF THE DECOMMISSIONING IN SPAIN



El Cabril Disposal

LILW

VLLW

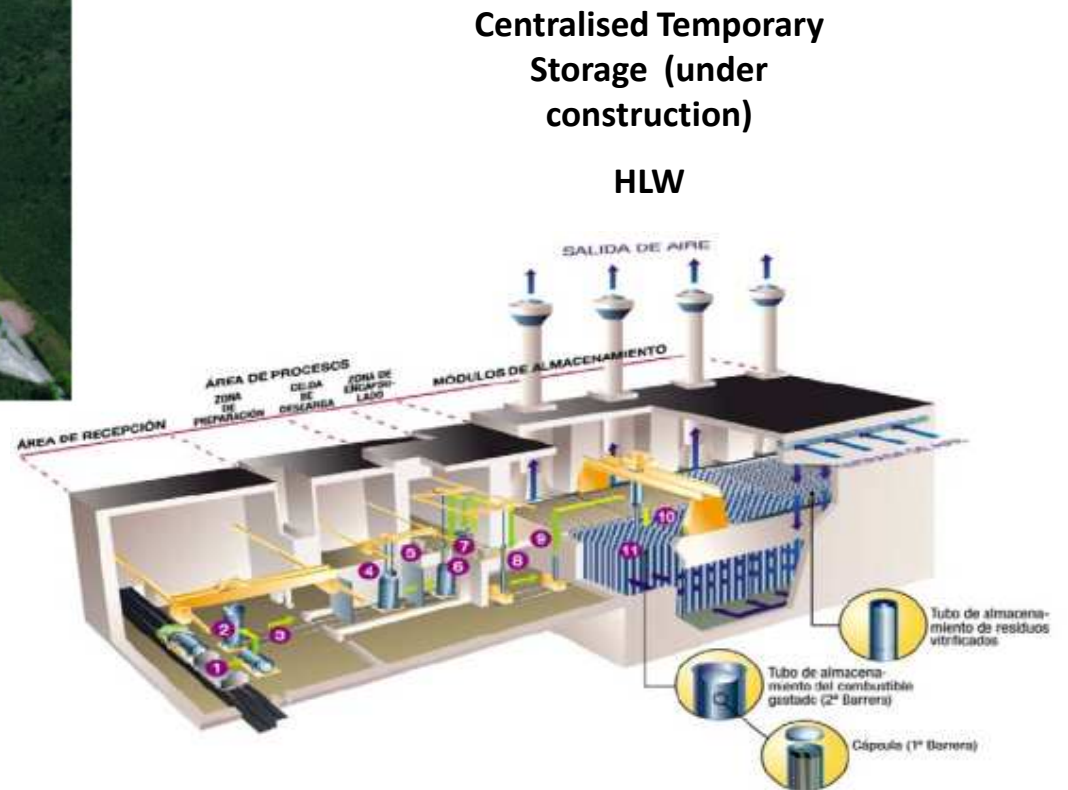

January 2016



engineering



WM & D&D in SPAIN



☐ SPANISH DECOMMISSIONING PROJECTS (ENRESA)

- ✓ Experience of Spanish decommissioning projects.

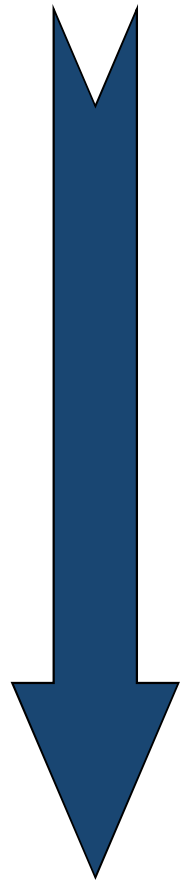

Lessons Learned



Vandellós I NPP



PIMIC

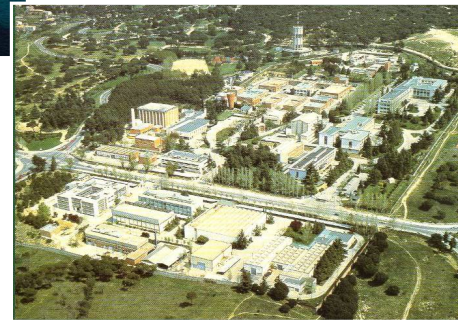

José Cabrera NPP



January 2016



engineering



WM & D&D in SPAIN

SPANISH DECOMMISSIONING PROJECTS (ENRESA)



January 2016



engineering



WM & D&D in SPAIN



☐ JOSE CABRERA NPP DECOMMISSIONING PROJECT

JC NPP Strategy selected.

- ✓ ENRESA selected as the more favorable option the immediate dismantling, **THREE YEARS** after the definitive shutdown.
- ✓ ENRESA proposed to undertake the total and immediate dismantling of the NPP, including the dismantling of all the structures, systems equipment and components, followed by the demolition of buildings, finalizing with the management of the generated wastes, and the restoration and liberation of the site

Regulations on Radioactive and Nuclear Installations, establishes that before the decommissioning Authorization, the owner will have to carry out:

- Unload the spent fuel of reactor and fuel storage pool
- Conditioning of radioactive waste generated during the operation

January 2016



engineering



WM & D&D in SPAIN



JOSE CABRERA NPP DECOMMISSIONING PROJECT

Life cycle of JC NPP

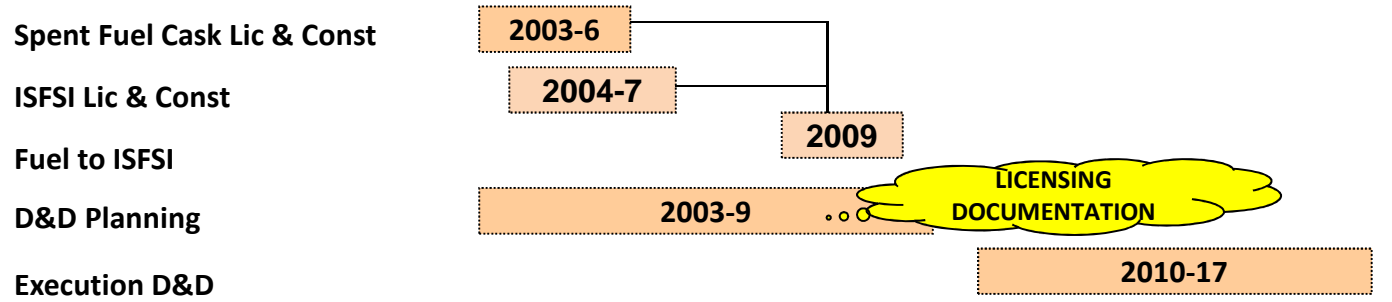
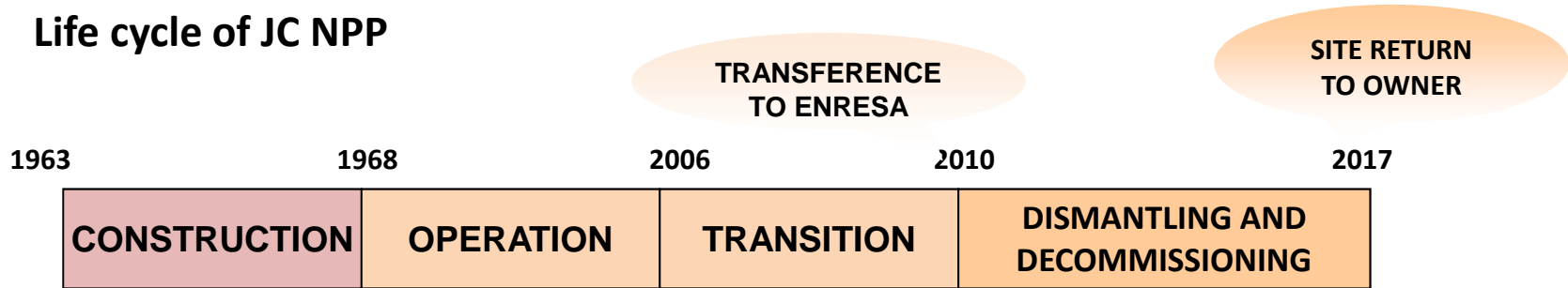

DISMANTLING AND DECOMMISSIONING PLAN

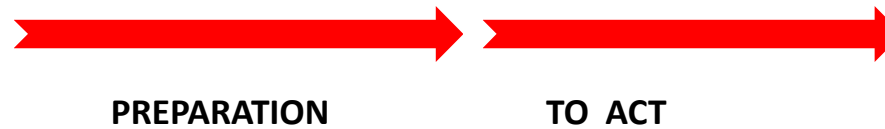

- ENRESA RESPONSIBILITY
- GNF RESPONSABILITY

January 2016



engineering



INDEX



- TOPIC ITEMS
- WM & D&D in SPAIN
- **JOSE CABRERA NPP DECOMMISSIONING STATUS (ENRESA)**
- RESEARCH AND DEVELOPMENT

January 2016



engineering



Pre Decommissioning Activities

❑ SPENT FUEL MANAGEMENT : 2003- 2010

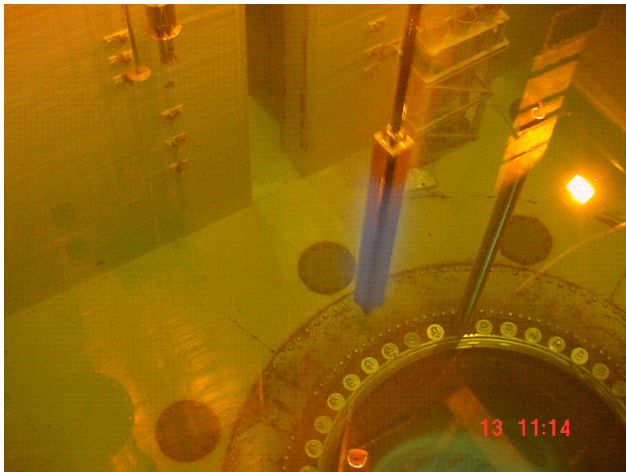

Design, licensing and implementation of
a Individual Temporary Storage

Container System licensing

NPP Design Changes

Fuel characterization and container load

SPENT FUEL TO ISFSI



January 2016



engineering

gasNatural
fenosa



Decommissioning Activities JC NPP



JOSE CABRERA NPP DECOMMISSIONING PROJECT

Decommissioning works after transference to ENRESA (February 2010 until today)

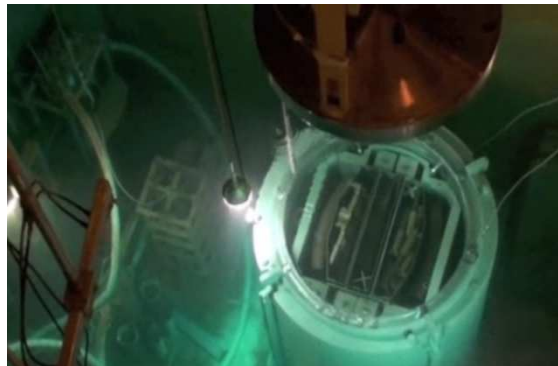

January 2016



engineering



Decommissioning Activities JC NPP

NEW INSTALLATIONS AND IMPROVEMENTS (2010-2012)



January 2016



engineering



Decommissioning Activities JC NPP



JOSE CABRERA NPP DECOMMISSIONING PROJECT

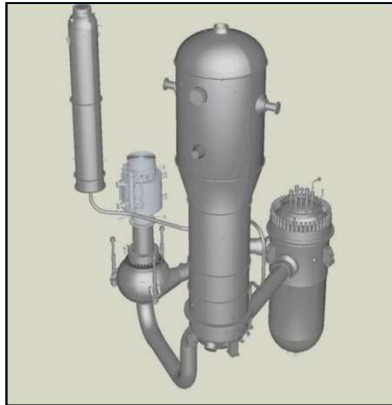

CE-2



Destination: El Cabril

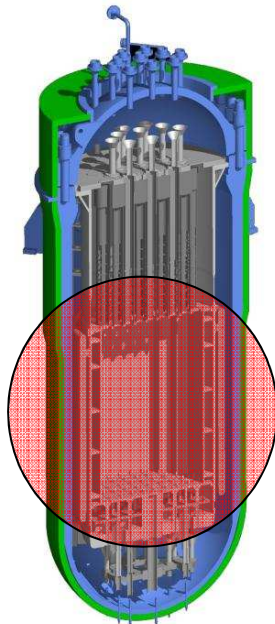

Max. activation zones

CE-2



Destination: ISFSI / ATC



GTCC/ SF Container



LARGE COMPONENTS DISASSEMBLY (2013-2015)

January 2016



engineering

gasNatural

fenosa

Decommissioning Activities JC NPP



☐ JOSE CABRERA NPP DECOMMISSIONING PROJECT

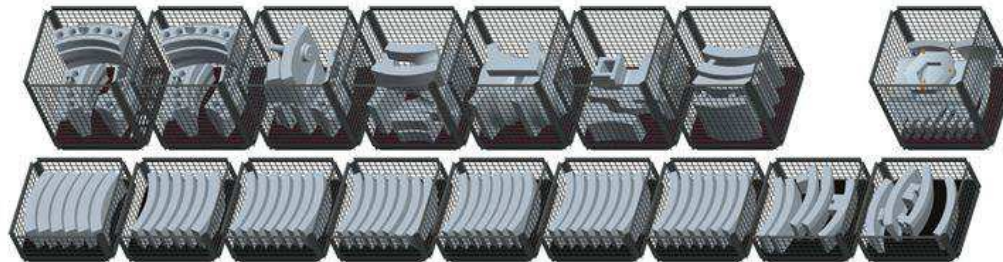

January 2016



engineering



Decommissioning Activities JC NPP



JOSE CABRERA NPP DECOMMISSIONING PROJECT

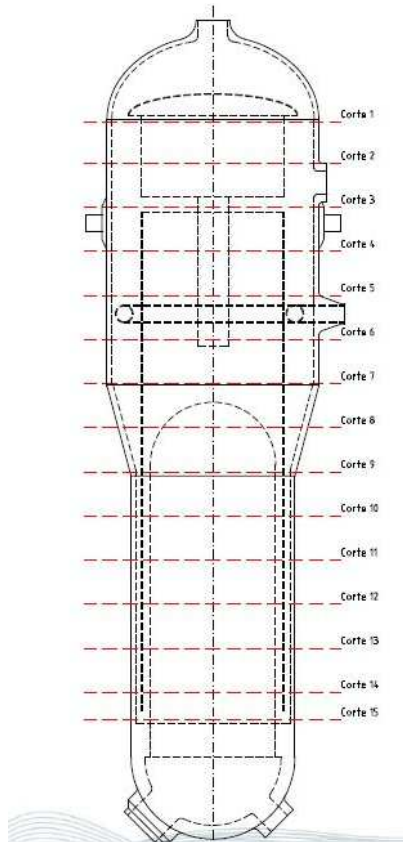

January 2016



engineering



Decommissioning Activities JC NPP



JOSE CABRERA NPP DECOMMISSIONING PROJECT

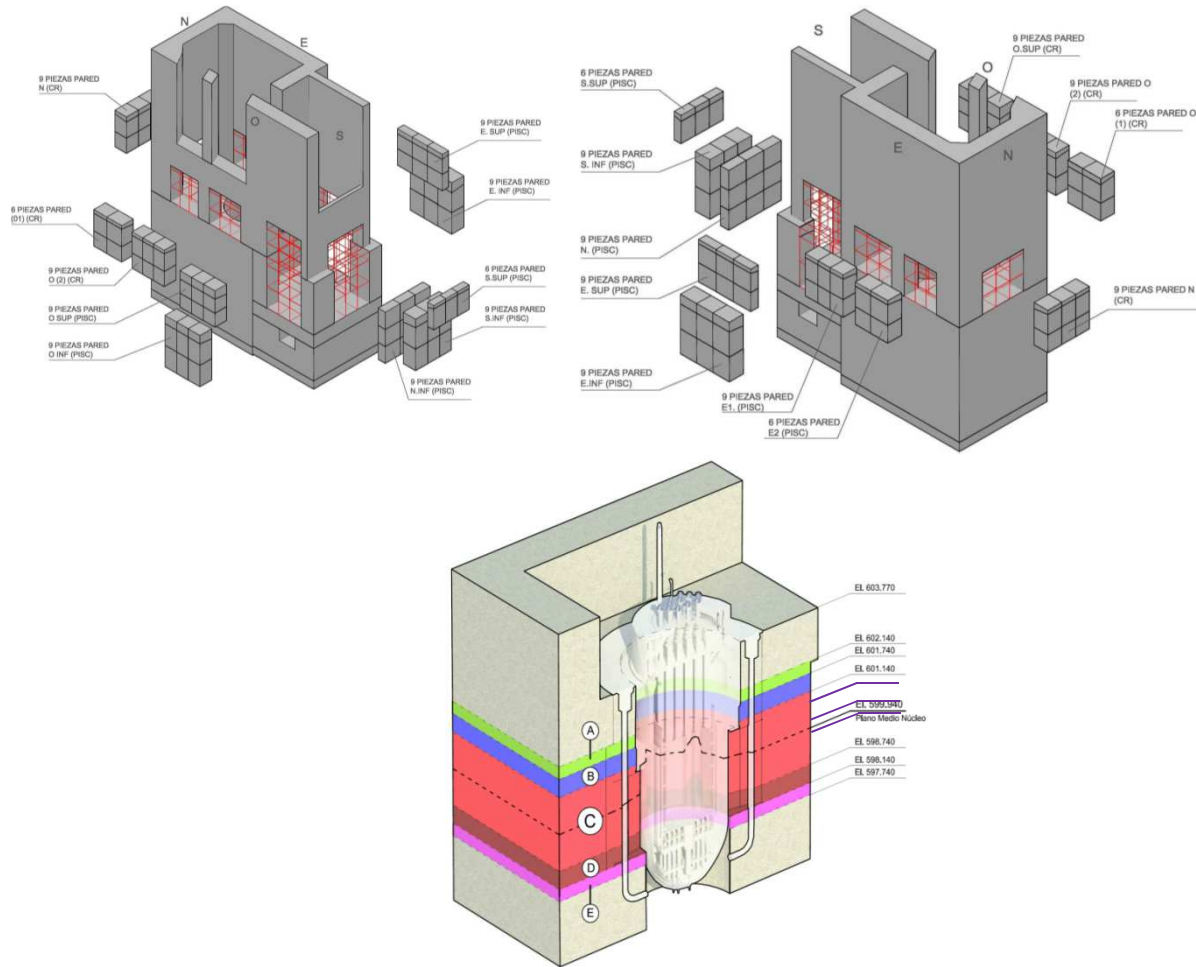

January 2016



engineering



Decommissioning Activities JC NPP



☐ JOSE CABRERA NPP DECOMMISSIONING PROJECT



January 2016



engineering



Decommissioning Activities JC NPP



☐ JOSE CABRERA NPP DECOMMISSIONING PROJECT



January 2016



engineering



Decommissioning Activities JC NPP



☐ JOSE CABRERA NPP DECOMMISSIONING PROJECT

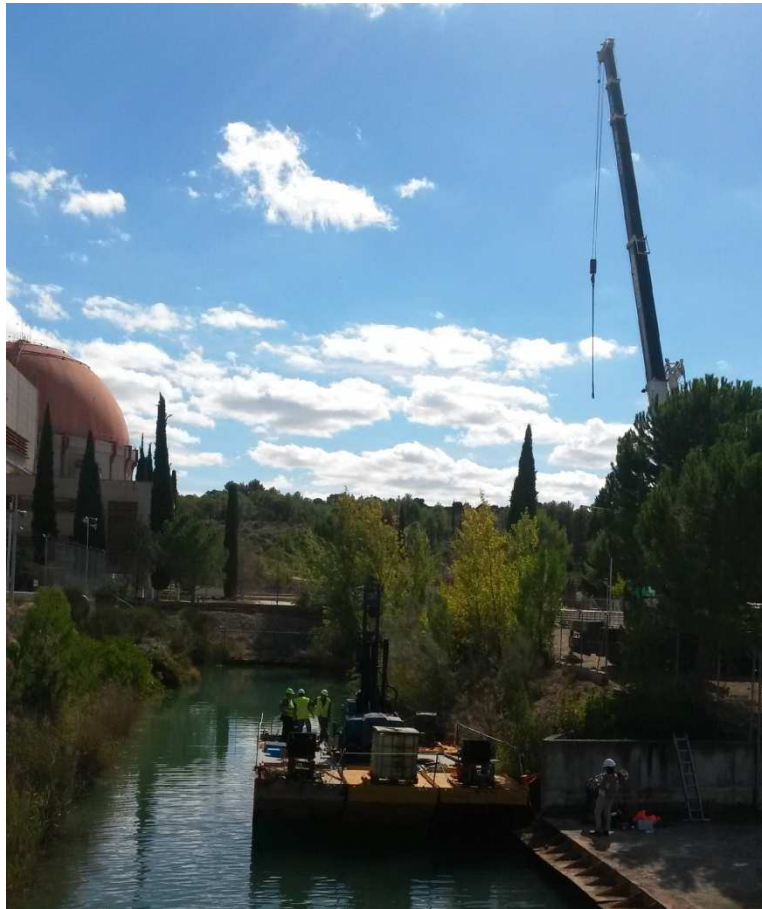

January 2016



engineering



Decommissioning Activities JC NPP



☐ JOSE CABRERA NPP DECOMMISSIONING PROJECT



January 2016



engineering



Decommissioning Activities JC NPP



☐ JOSE CABRERA NPP DECOMMISSIONING PROJECT



The future....



January 2016



engineering



INDEX



- TOPIC ITEMS
- WM & D&D in SPAIN
- JOSE CABRERA NPP DECOMMISSIONING STATUS
- **RESEARCH AND DEVELOPMENT**

- **CEIDEN**

January 2016



engineering



Decommissioning as opportunity...

- Research projects associated with dismantling works

Launched

- ✿ Reactor Internals - ZIRP
- ✿ Concrete harvesting
 - ✿ Biological Shielding :
 - ✿ SFP concrete , reactor cavity concrete

Other potencial

- Cable aging
- Underground pipes
- Land Quality

ZIRP Activities

ZIRP – Zorita Internals Research Project

8 samples will be extracted from the Reactor Internals :

- 2 samples of core barrel welding
- 6 samples of baffle

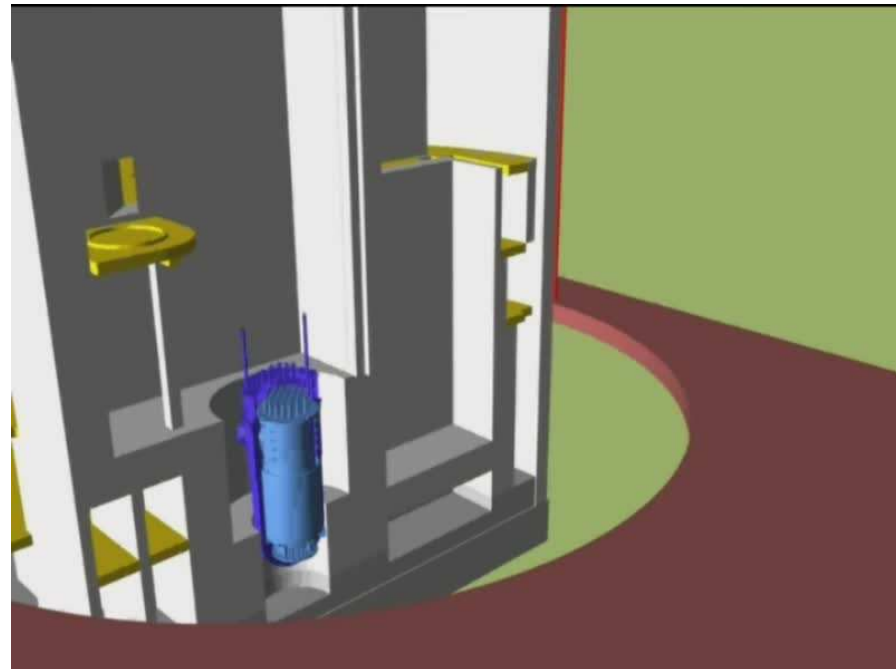

January 2016



engineering



ZIRP Activities

ZIRP – Zorita Internals Research Project

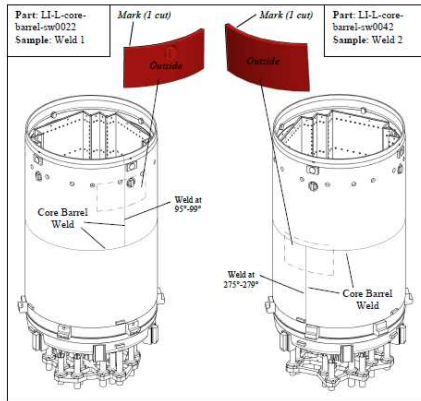

Core Barrel Weld

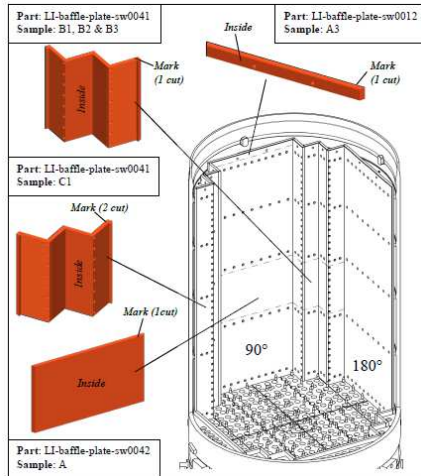

Baffle samples

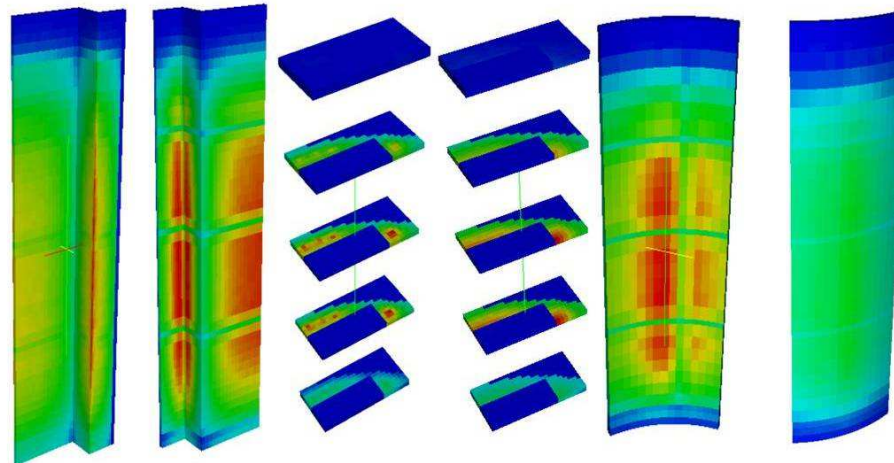
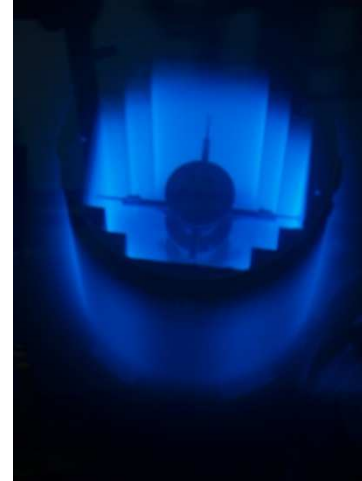

January 2016



engineering



ZIRP Activities

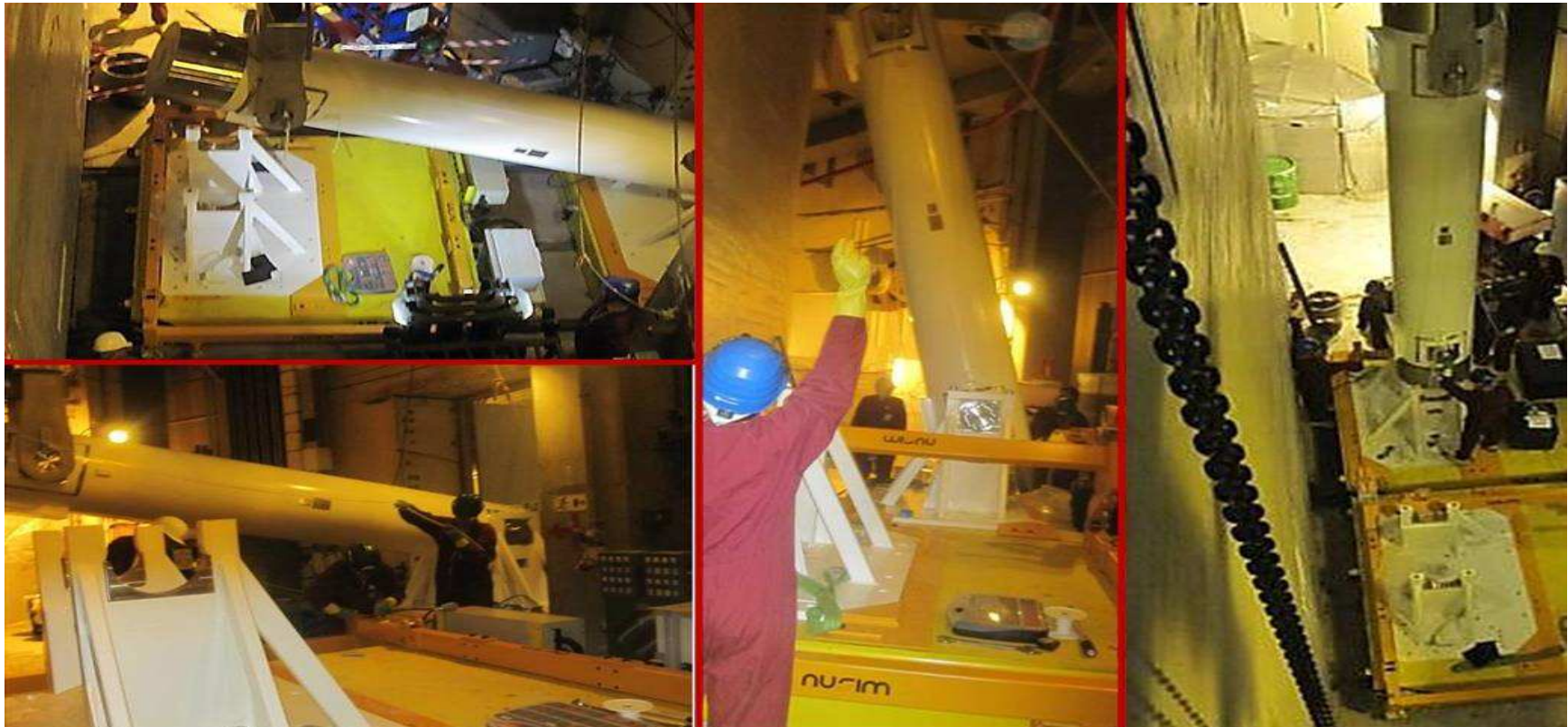

January 2016



engineering



ZIRP Activities

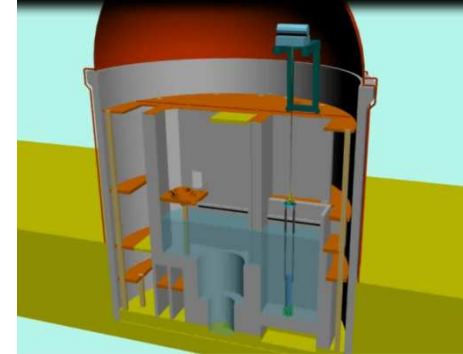
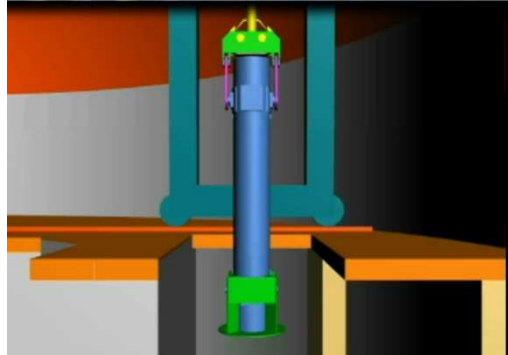

Task	2007	2008	2009	2010	2011	2012	2013	2014	2015	2016
Project Inception	★									
Feasibility Study										
Project Planning Cutting Plans Equipment Design & Manufacturing On-site Preparations										
Material Extraction On-site Logistics Shipping										
Radiation and Temperature Analyses										
Material Inspection, Inventory, Documentation										
Materials Testing										
Reporting										★

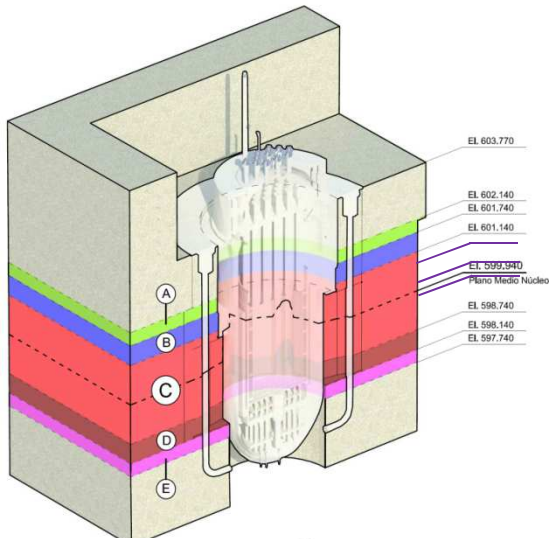

Zorita NPP Concrete Harvesting

Analyze the ageing of the main concrete elements subjected to high irradiation and temperatures, as well as chemical atmospheres, during the plant operating life

Five zones with different radiological classification according their levels

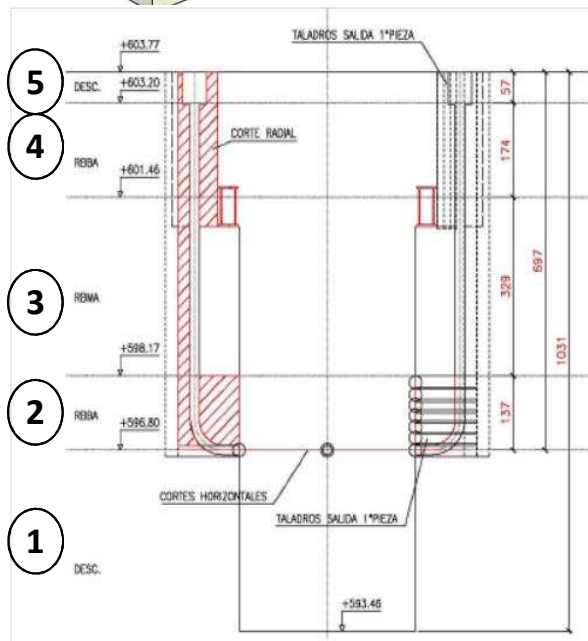

1. From bottom to level +596.79 → Desc.
2. From level +596.80 to level +598.16 → VLLW
3. From level +598.17 to level +601.45 → LILW
4. From level +601.46 to level +603.19 → VLLW
5. From level +603.20 to level +603.77 → Desc.

January 2010



Segmentation Plan

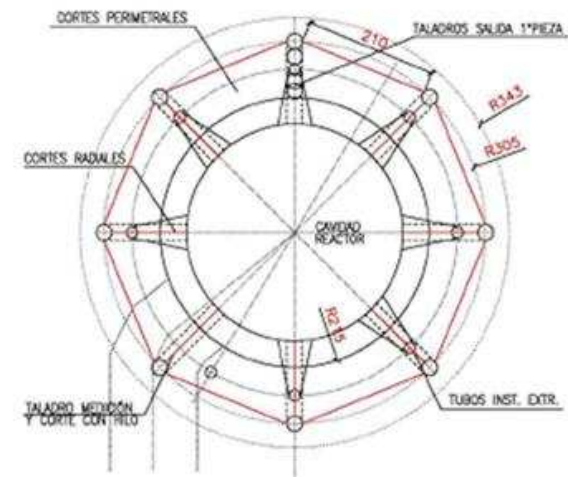
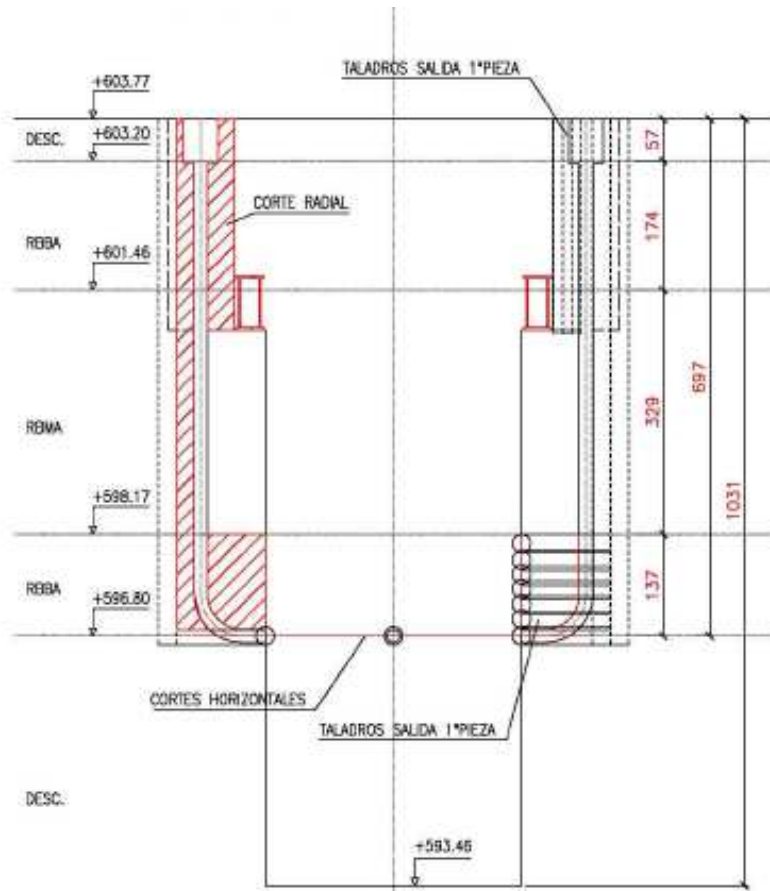

January 2016



INDEX



- TOPIC ITEMS
- WM & D&D in SPAIN
- JOSE CABRERA NPP DECOMMISSIONING STATUS
- **RESEARCH AND DEVELOPMENT**

- **CIEMAT**

January 2016



engineering



CIEMAT- R&D on the Topic

- **Radiological Protection of the Public and Environment**
 - Development of methodologies, models and tools for environmental impact assessment of radioactive waste management
 - Radiological Impact of Natural and Artificial Sources of Radiation
 - Radiological Protection in Intervention Situations
 - Analysis of the physico-chemistry of actinides and fission products
- **Physic-chemistry of Actinides and Fission Products → Disposal**
 - Analysis of the physico-chemistry of actinides and fission products
 - Characterization of colloids and nanoparticles: Relevance on contaminant migration
- **Radiation Dosimetry**
 - Radiation Dosimetry Service & R+D Dosimetric Methods and Models
- **Environmental Radioactivity and Radiological Surveillance**
 - Environmental Radiological Surveillance Programm (ERSP)
 - CIEMAT (normal operation, dismantling, closure, post- closure)

January 2016



engineering

gasNatural
fenosa



CIEMAT- Waste Management

- Waste Characterization to establishing Nuclide Vectors
 - Radiological characterization by DA of primary waste fluxes (resins, concentrates, sludge, i-graphite, concrete, steel, soils, wipes,...)

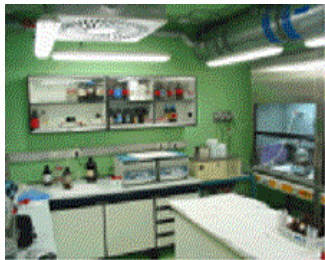

- Radiological characterization by NDA. 220 L drums by gamma scanning
- Basic Chemical characterization (liquid wastes)
- Structural Characterization
- Matrix Characterization (Mechanic & Physic-chemical)



Janu



engineering



gas natural
fenosa



Thanks for your attention

January 2016



engineering

