

Fukushima Daiichi Nuclear Accident;

based on the Final Report of Atomic Energy Society of Japan

Prof. Naoto Sekimura, Ph.D

Department of Nuclear Engineering and Management

The University of Tokyo

Contents

- ***The Earthquake and Tsunami on March 11, 2011***
- ***The Accident in Fukushima Daiichi Nuclear Power Plants after the Earthquake and Tsunami on March 11, 2011***
 - ***Loss of Power Source and Ultimate Heat Sinks***
 - ***Core Damage and Integrity of RPV and RCV in Units 1, 2 and 3***
 - ***Release of Radioactive Materials***
 - ***(Spent Fuel Pools in Unit 4)***
 - ***(Decontamination of Radioactive Materials)***
- ***Root Causes of the Accident from the viewpoint of Defense-in-Depth for Nuclear Safety***
- ***Recommendations made by the AESJ Investigation Committee***

The Main Shock (and Aftershocks) of the Earthquake on March 11, 2011

March 11 to May 13, 2011

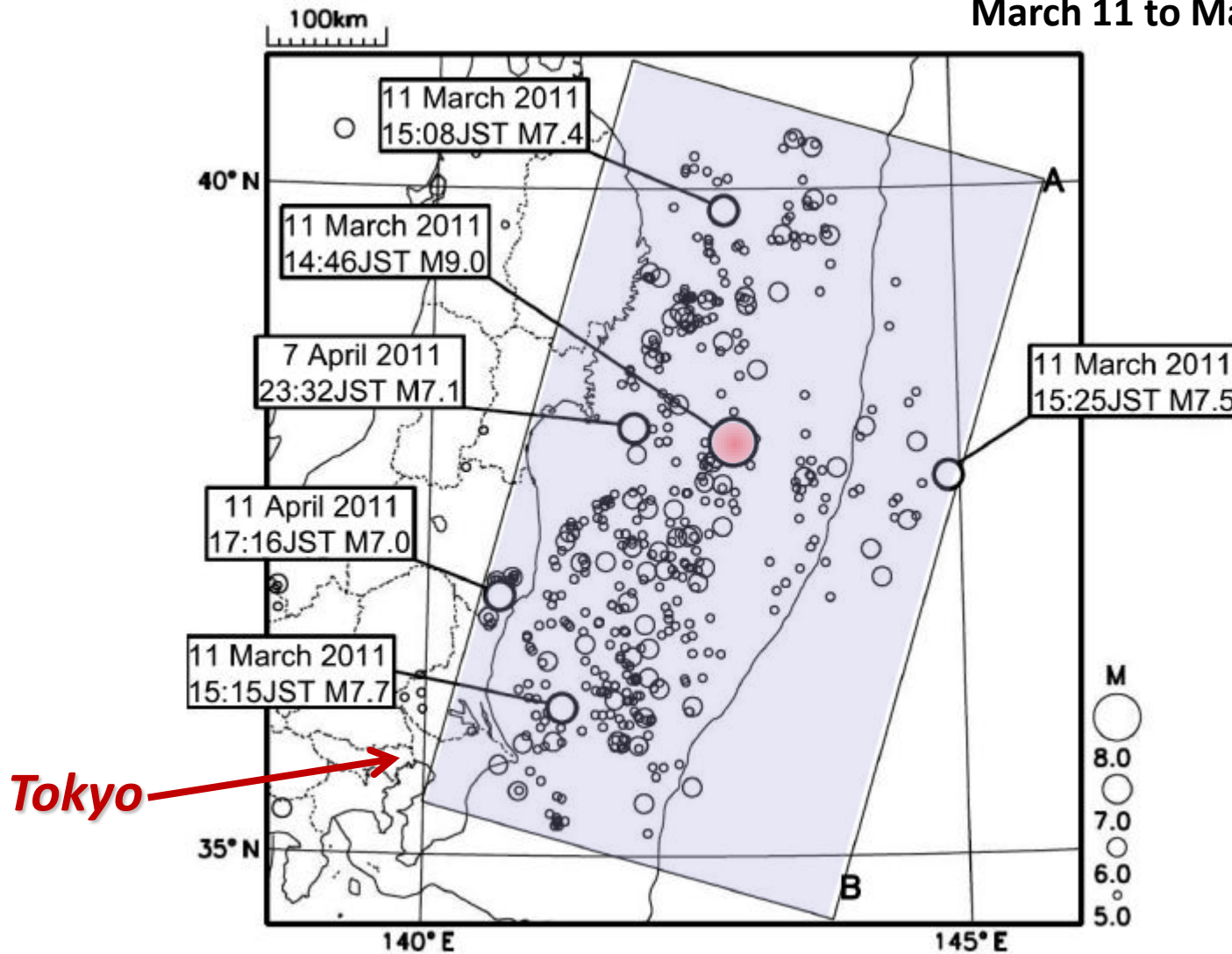

Tsunami after the Earthquake on March 11, 2011

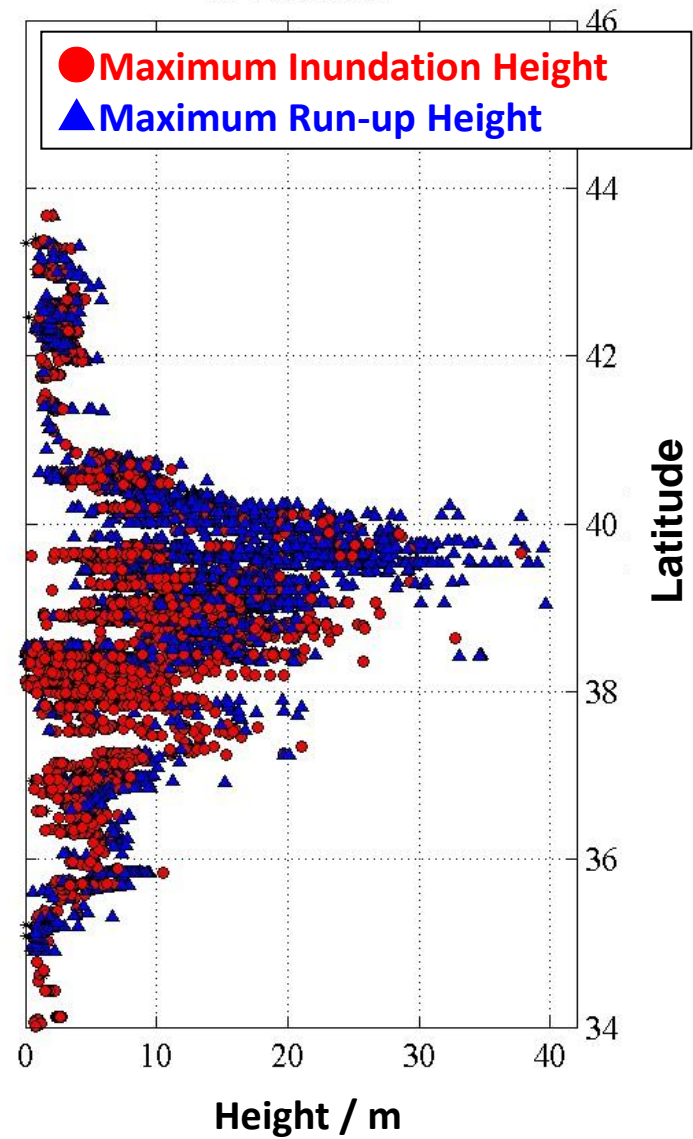
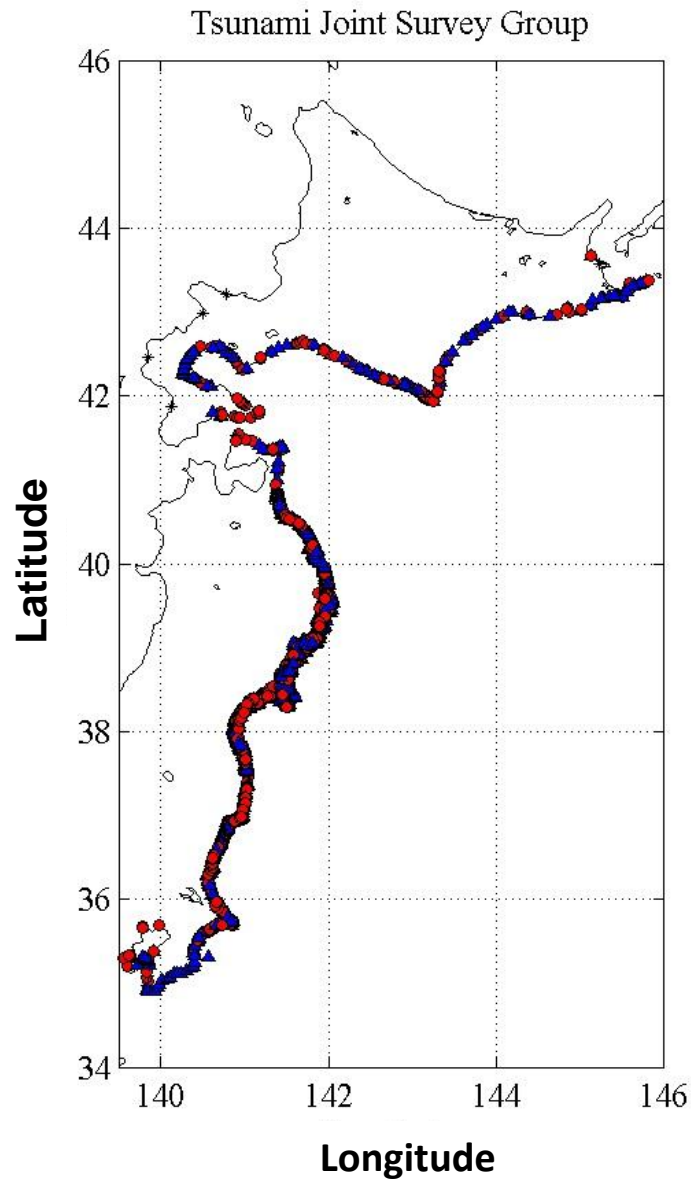

Fukushima Daiichi Nuclear Power Plant operated by TEPCO

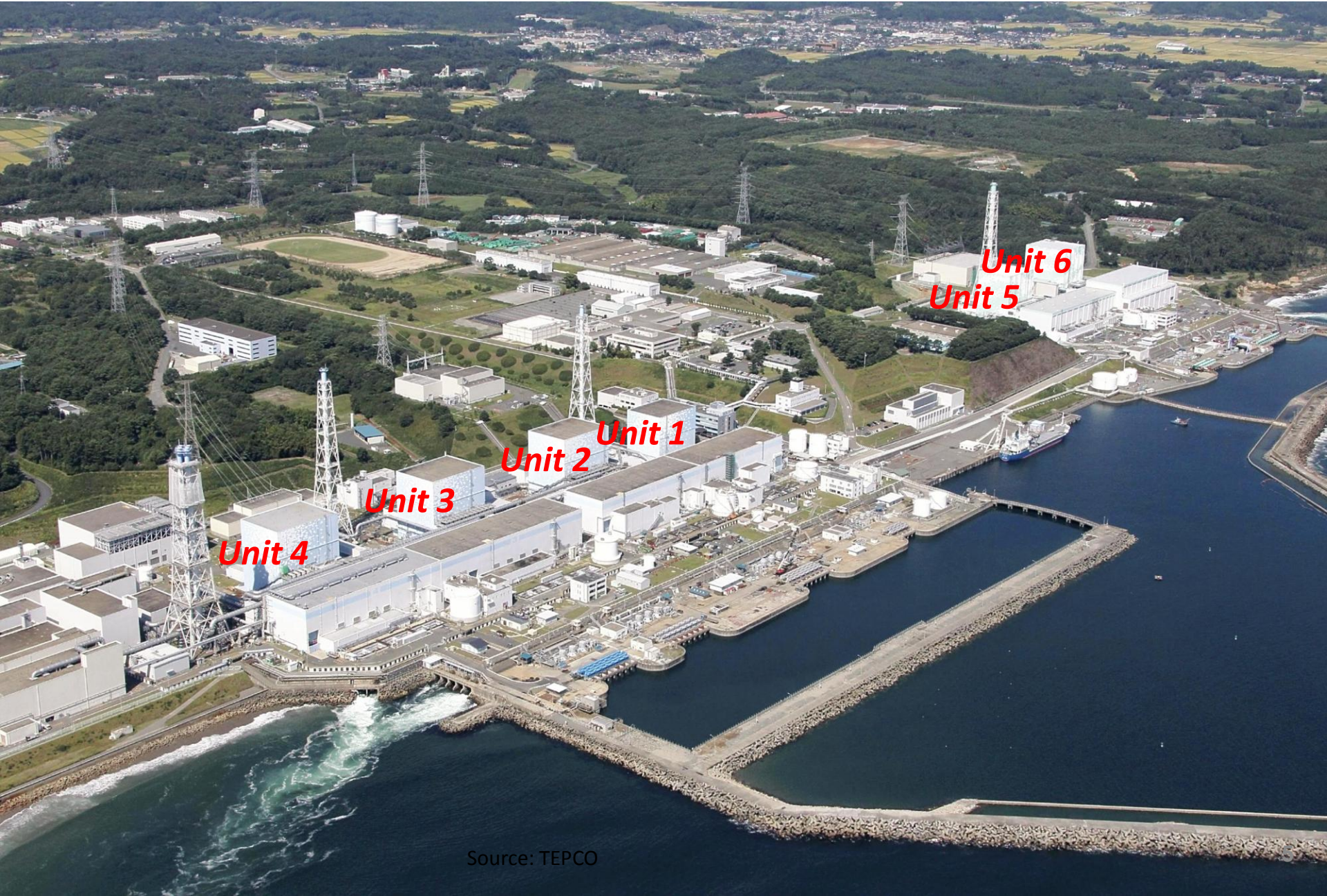

Mark-I and Mark-II Primary Containment Vessel (6 BWR Units in Fukushima Daiichi)

***Unit 1
(Mark-I)***

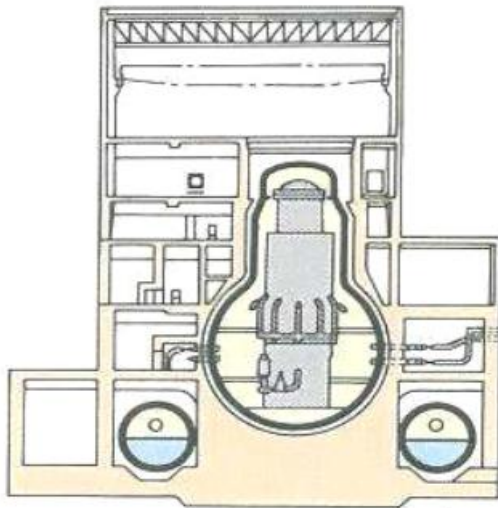

460 MWe

***Units 2,3,4 and 5
(Mark-I)***

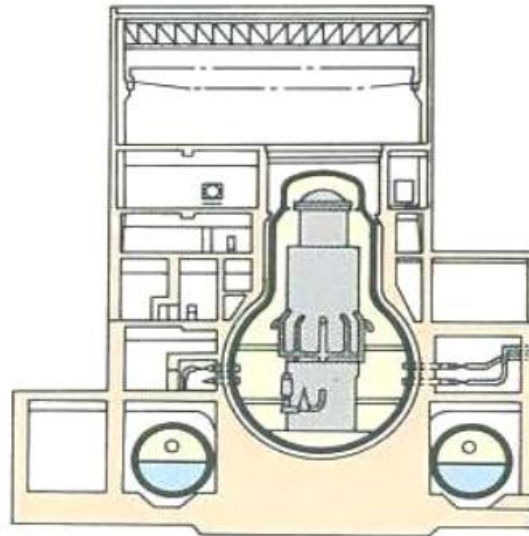

784 MWe

Unit 6 (Mark-II)

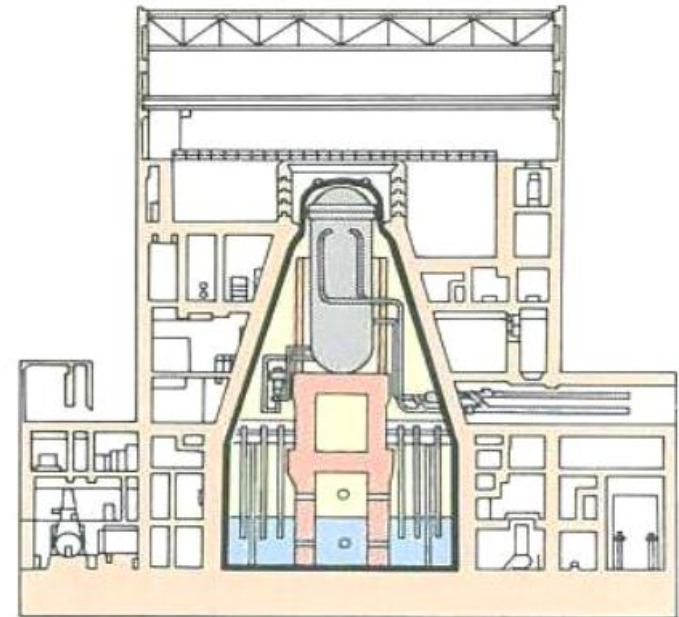

1,100 MWe

- Volume of Mark-II containment vessel is larger than that of Mark-I.
- Units 1-3 were operating at the time of the Earthquake.
- Unit 4-6 were in refueling outage

BWR with Mark-I Type Containment Vessel (Fukushima Daiichi, Units 1,2,3,4 and 5)

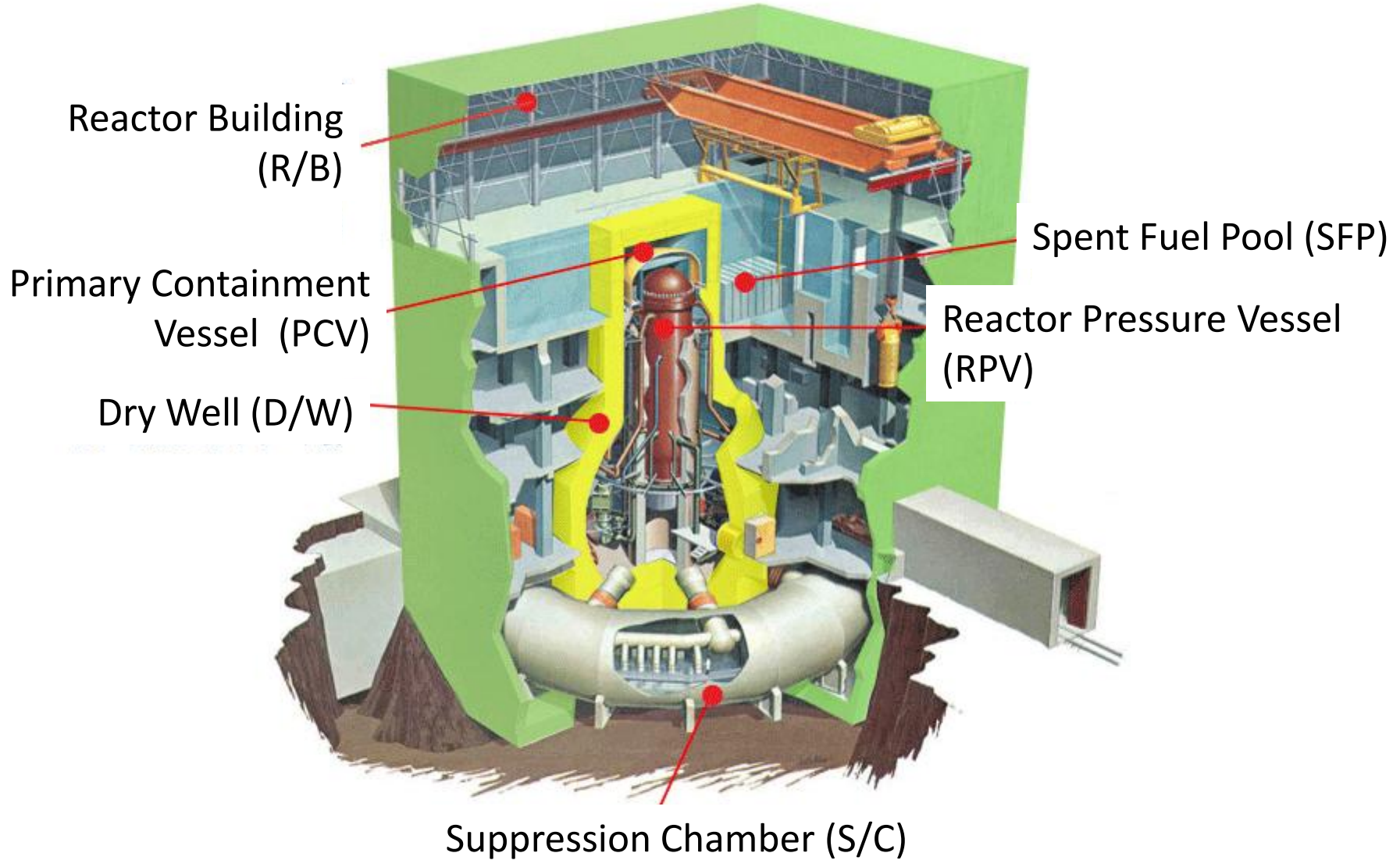

Tsunami on March 11, 2011

Fukushima Daiichi



Tsunami, March 11, 2011

15:36:10



15:36:16



15:36:56



15:37:06



15:37:24



15:37:48



15:38:14



15:38:28



15:39:40



15.5 m above
the sea level



Source: TEPCO

Inundation height of the Tsunami in Fukushima Daiichi was about 15.5 m above the sea level.

(Correction of Time based on TEPCO)

Tsunami Flood in Units 1-4

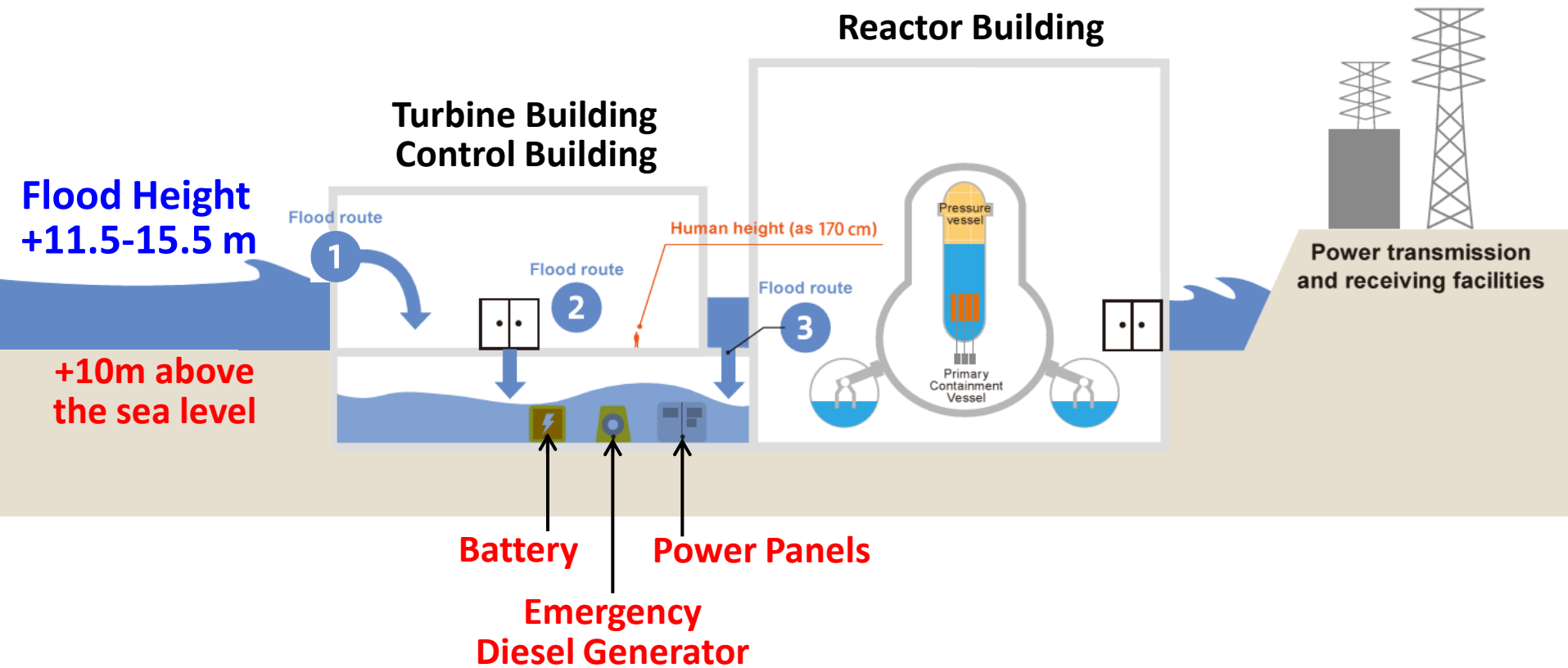

Assumption of Tsunami Height was Max. 6.1 m before the Accident.

Flood Route to the Basement of Turbine Building

- ① Air Supply Louver for Emergency Diesel Generator
- ② Turbine Building Entrance
- ③ Component Hatch

Loss of Power Supply in Units 1-4

Loss of the External Power Supply

Breakers were broken due to the earthquake

Okuma 3L : Under modification

Loss of all the EDG Functions either by

- 1) Damage in Generator
- 2) Loss of Sea-Water Cooling System
- 3) Damage at Power Panels
by the Tsunami flood

Loss of DC Battery except for Unit 3

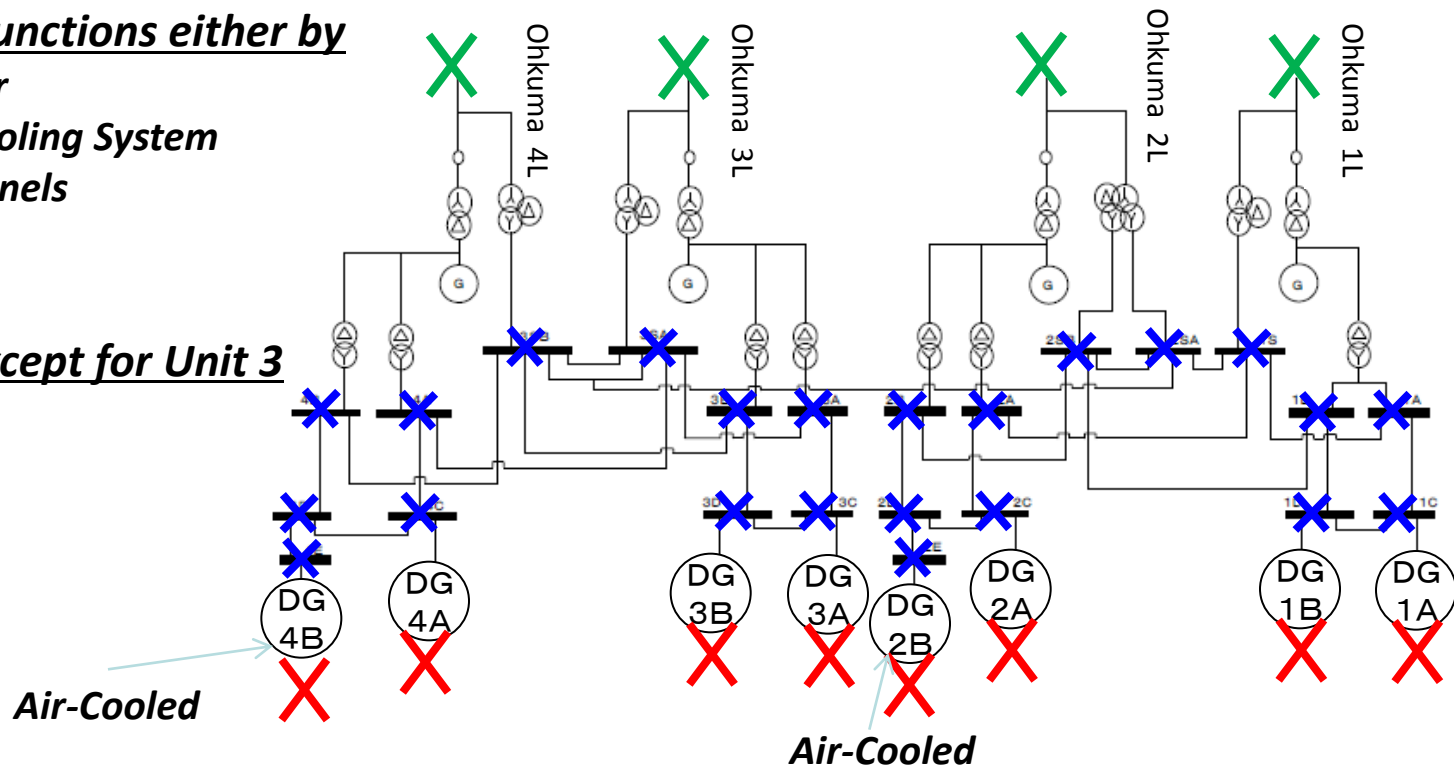

(EDG : Emergency Diesel Generator)

* Recovery of Off-site Power Supply

Unit 2 on March 20, Units 1,3 and 4 on March 22

One Air-Cooled DG (DG6B) survived in Units 5 & 6

Loss of Off-site Power Supply

- Collapse of Pylons by the Earthquake



Survival of One Air-Cooled Diesel Generator

Survival of DC Battery

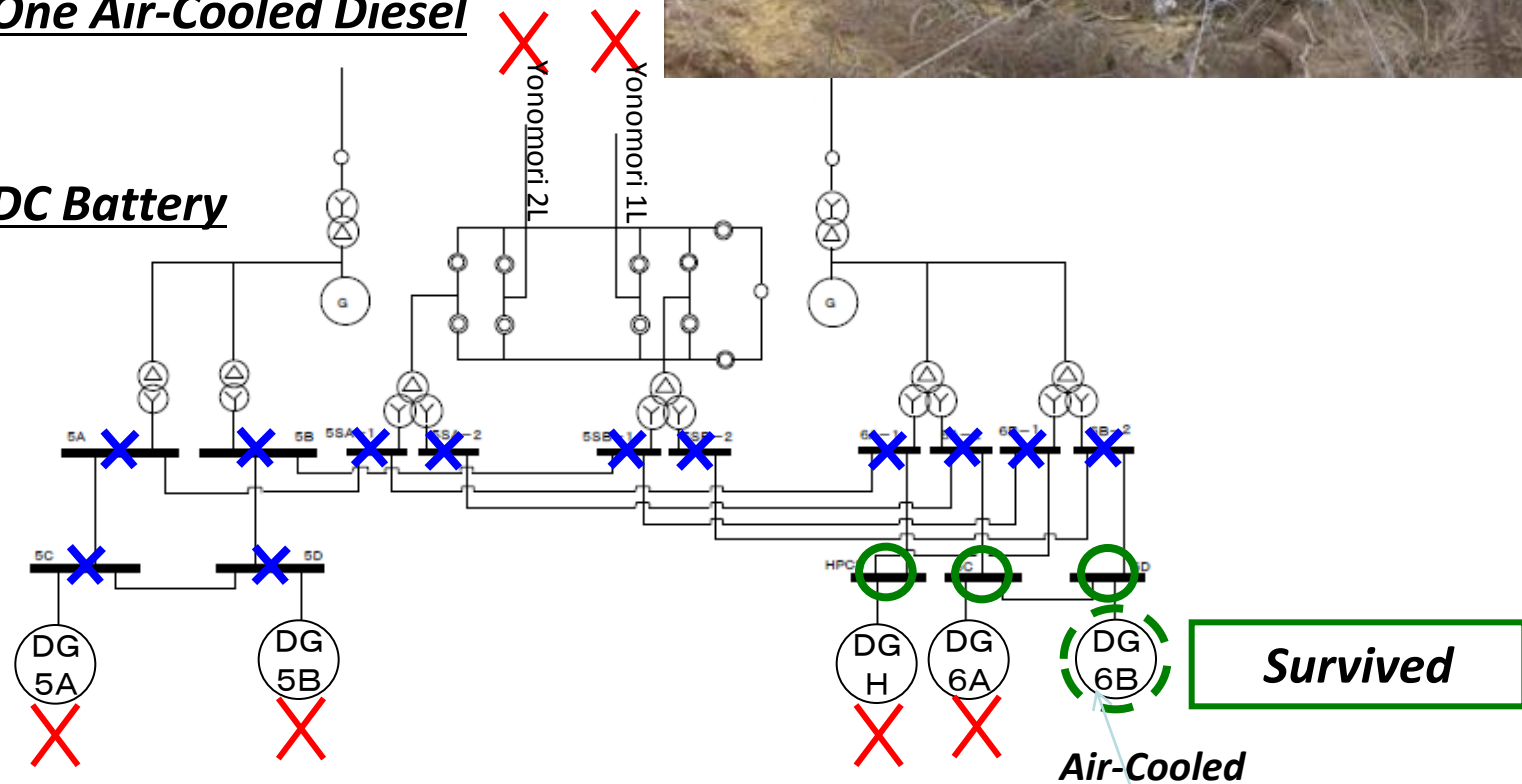

Damage in sea-water cooled EDGs by the Tsunami

* Recovery of Off-site Power Supply on March 20-21

Photographs from One of the Fukushima 50



Source: TEPCO

- **After the Tsunami,**
 - **No lighting available**
 - **What they can get are flashlights, batteries (some are removed from automobiles), fire trucks and some compressors**
 - **Very difficult to measure the major safety parameters like water level, reactor pressure, CV pressure**
 - **No communication tools between the Emergency Response Room and workers at the field**

Fundamental Safety Functions for Light Water Reactors

Shutting Down by interrupting fission chain reaction through insertion of control rods

Cooling Down the fuels through continuous water injection and circulation

Confining radioactive materials inside the boundary (RPV and PCV)

Decay Power and Radioactive Materials in Units 1, 2 and 3

Decay Heat after the Shut-down

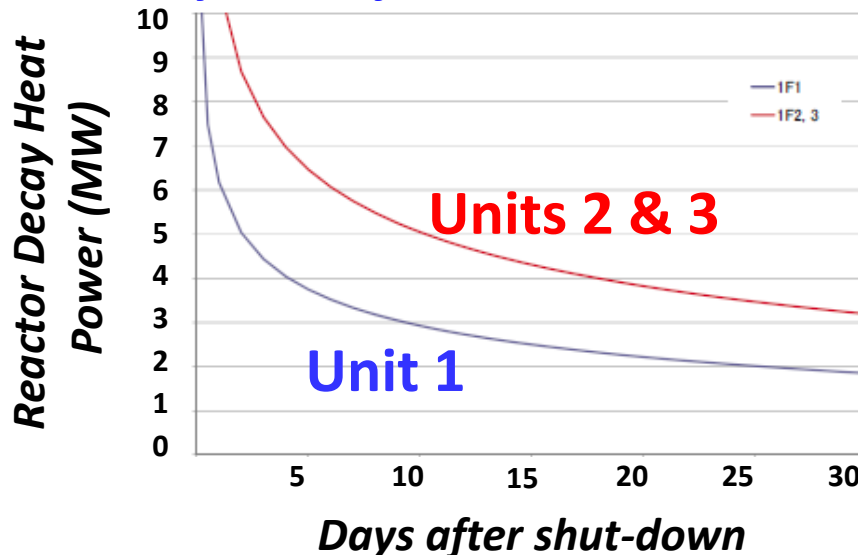

Source Term just after the Shut-down

Unit 1

I-131 : 1.9×10^{18} Bq

Cs-137 : 2.0×10^{17} Bq

Unit 2

I-131 : 2.7×10^{18} Bq

Cs-137 : 2.4×10^{17} Bq

Unit 3

I-131 : 2.7×10^{18} Bq

Cs-137 : 2.4×10^{17} Bq

Isolation Condenser (IC) in Unit 1

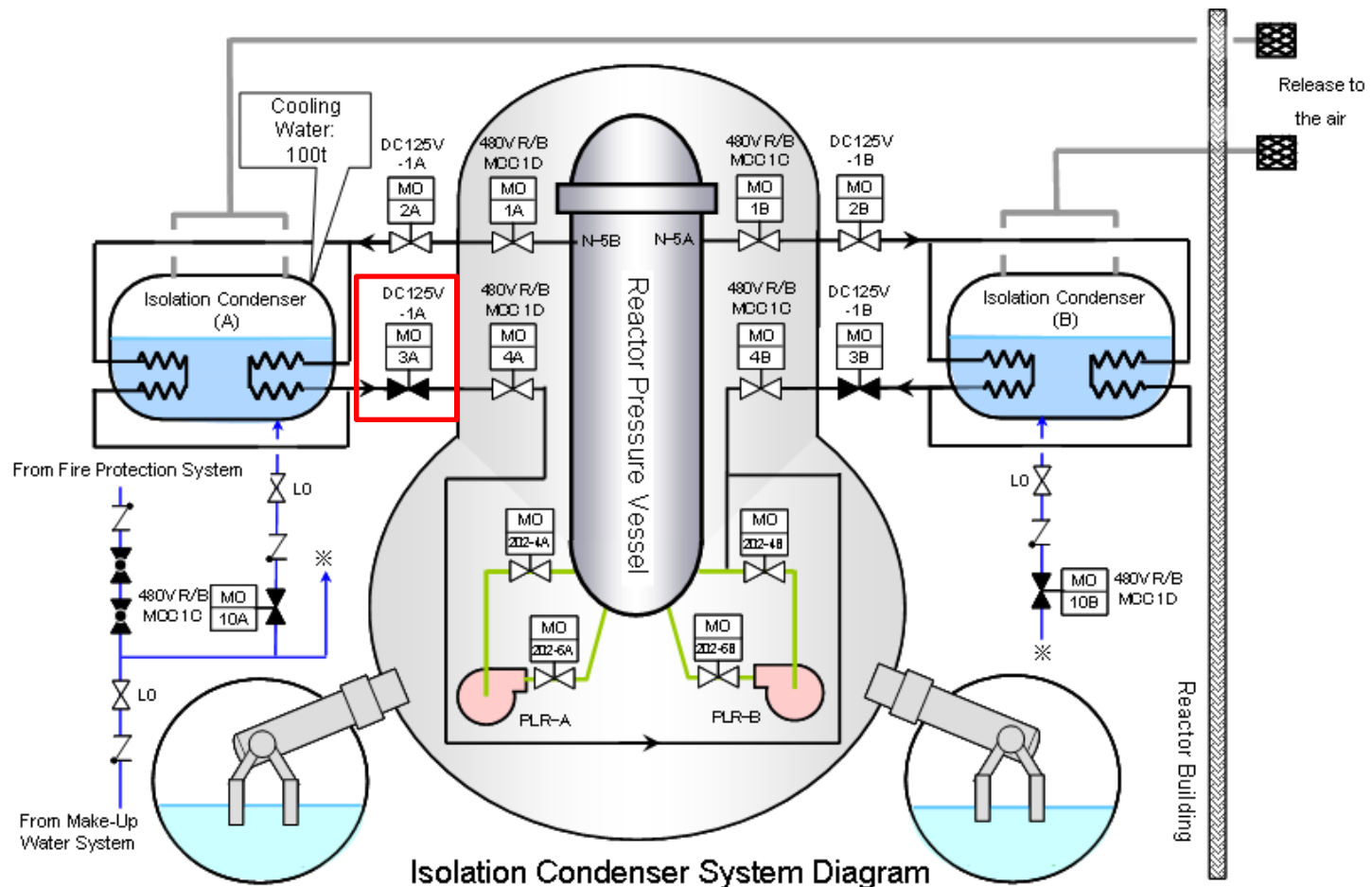

Core damage in Unit 1 progressed in a short period of time after the tsunami. The status of the IC, which is used to cool the reactor in the initial stages after shutdown, have affected the event progression.

Fuel Rods, Fuel Assemble and Core of BWR

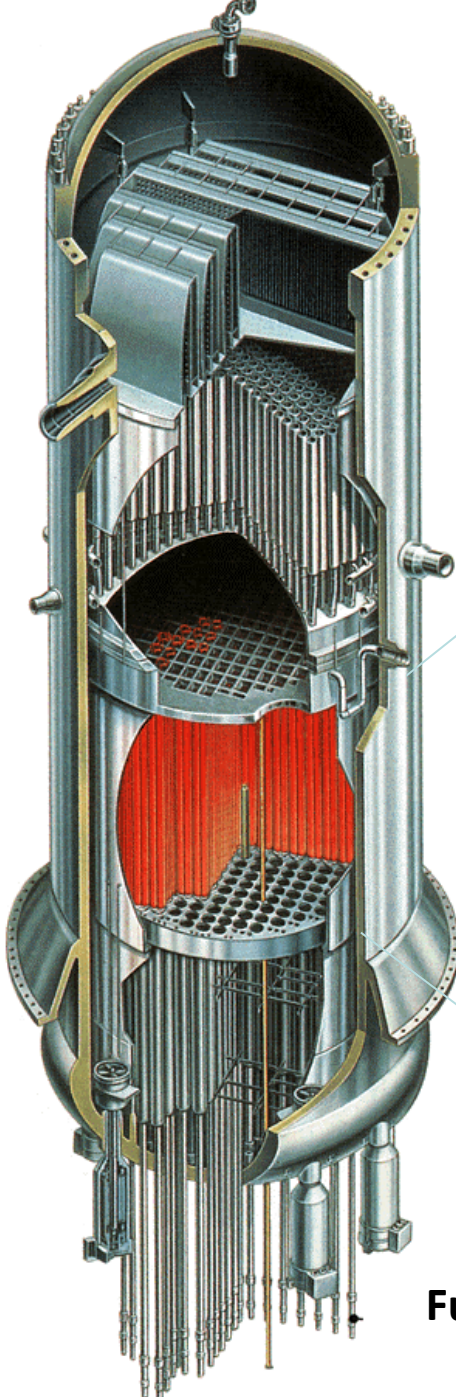

Fuel Assembly

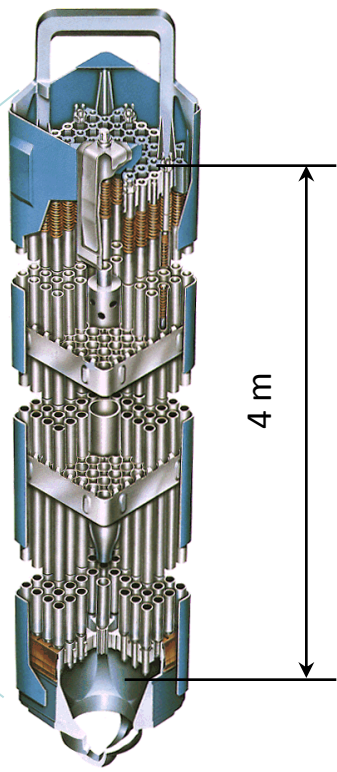

Fuel Rod

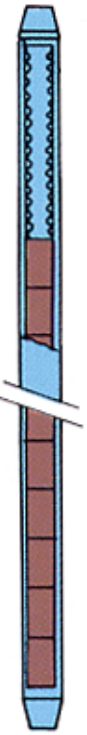

Cladding tubes (Zirconium alloy)

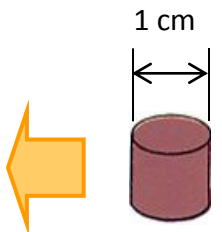

UO₂ pellet

Fuel Assemblies in the Core : 400 in Unit 1

548 in Units 2 and 3

Water Level in Unit 1

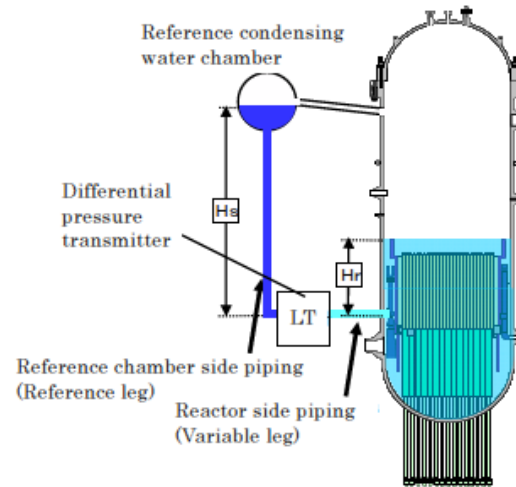
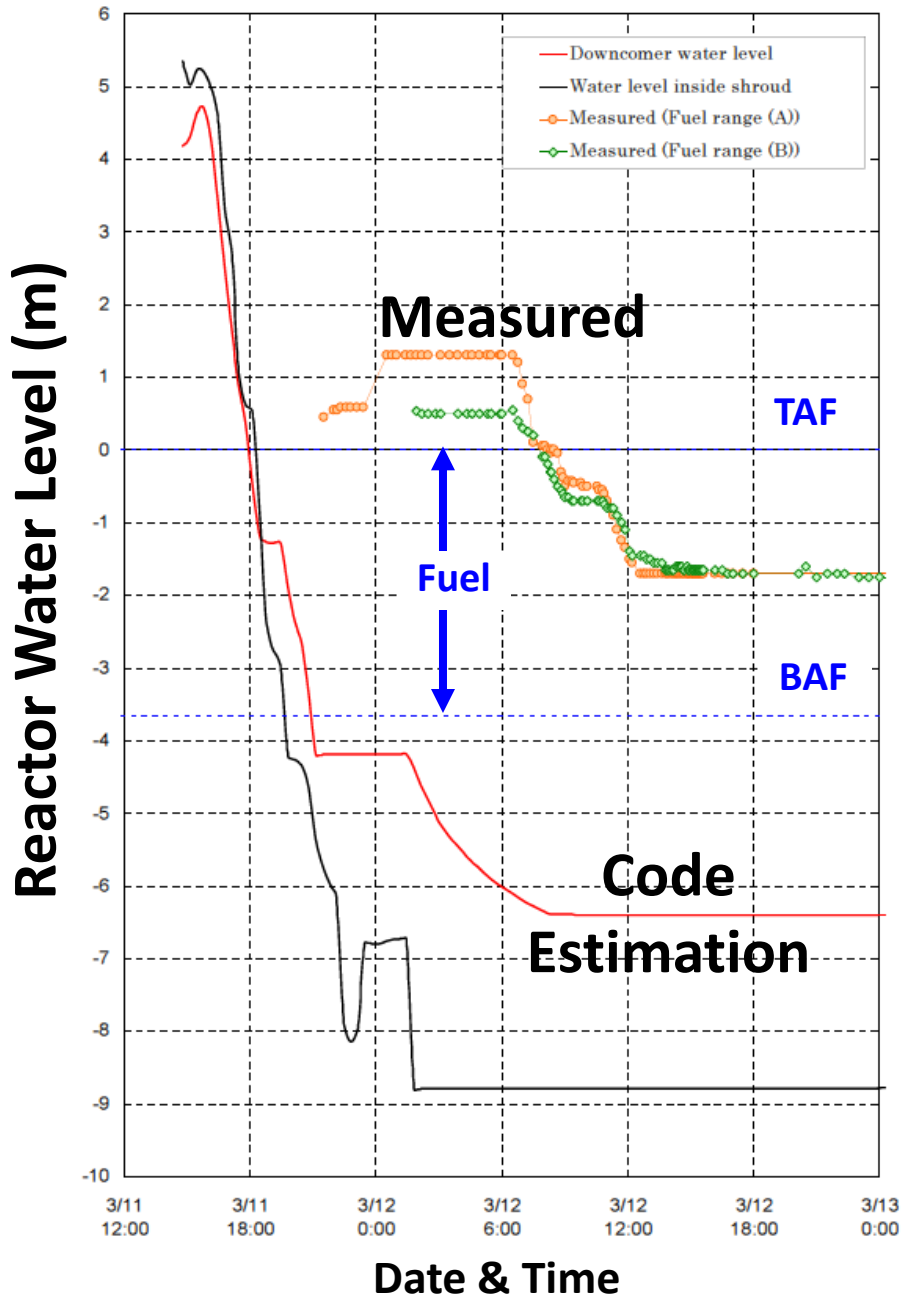
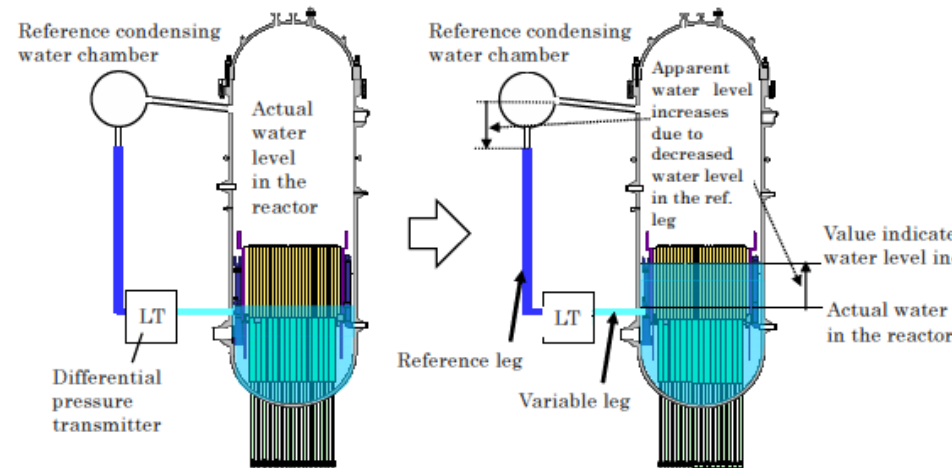
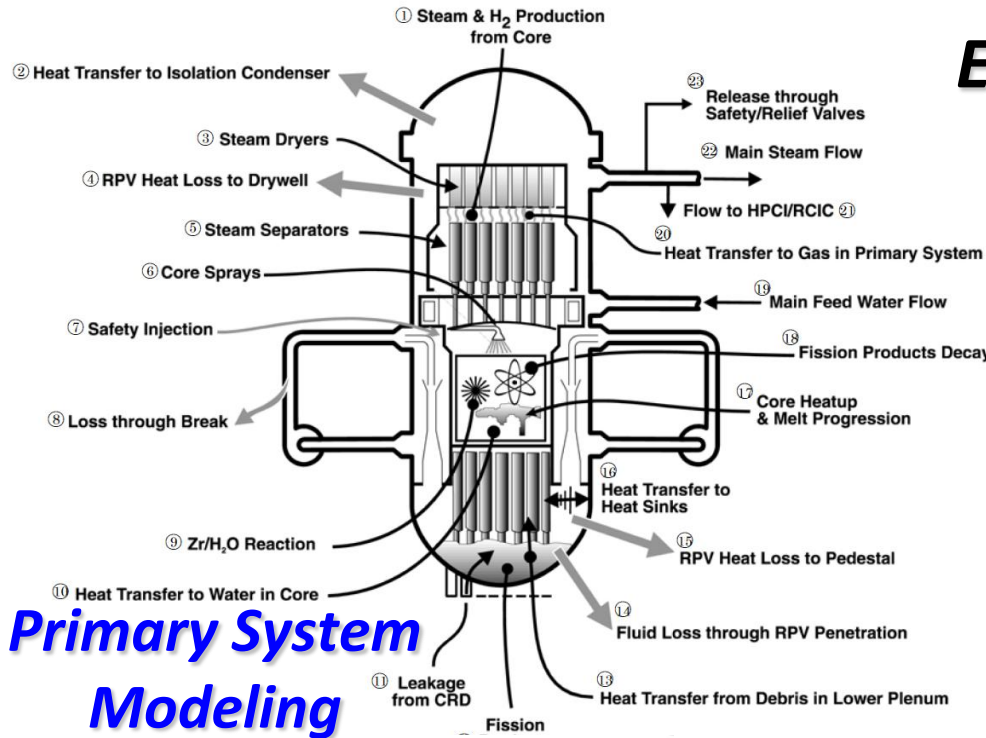

Figure 1 Fuel range water level indicator



Elementary Models in the Accident Analysis Code



Primary System Modeling

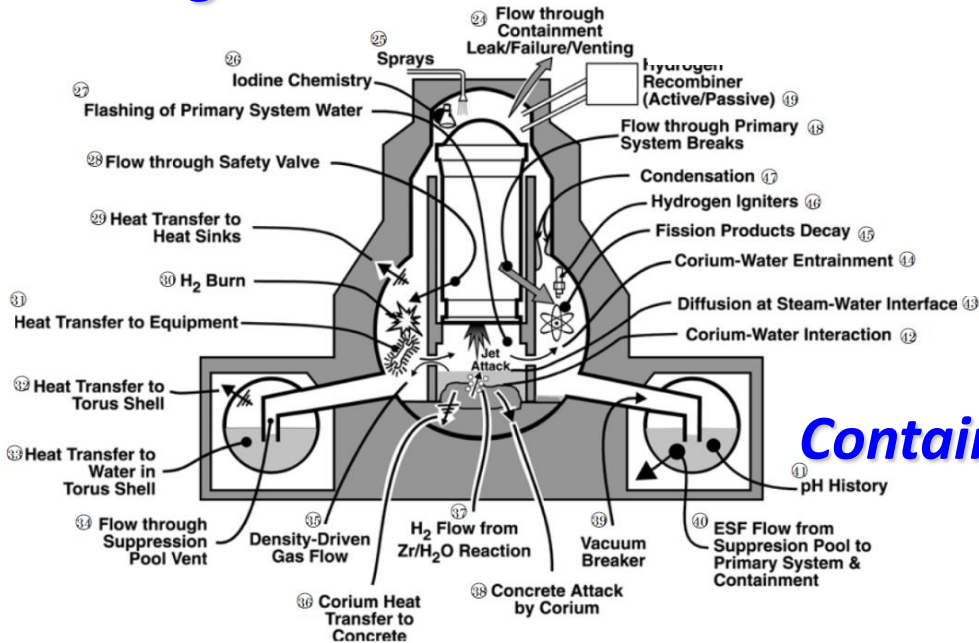

Containment Modeling

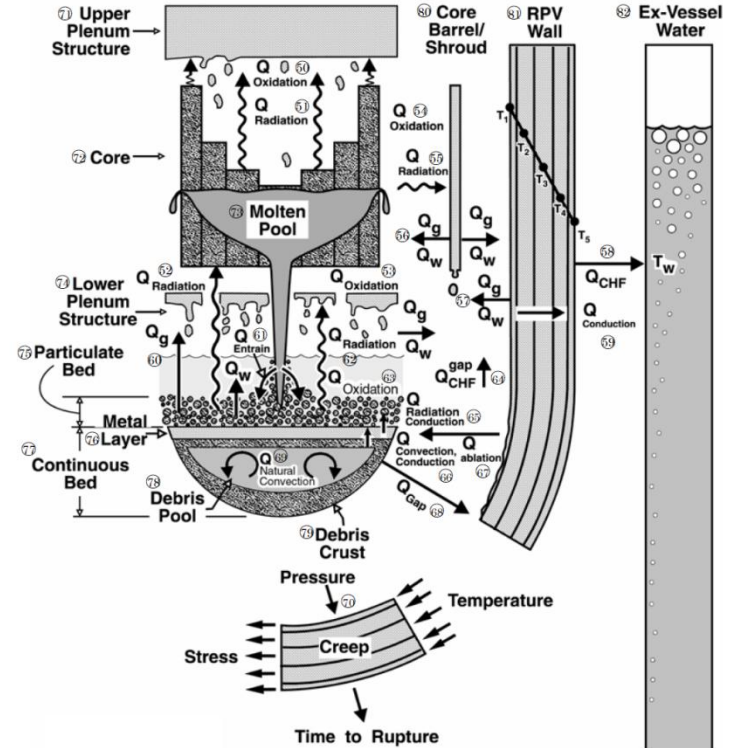

Lower Plenum Modeling

Example of the MAAP code

Estimated Core Damage in Unit 1

- Simulation Results of Fuel Damage by the MAAP code -

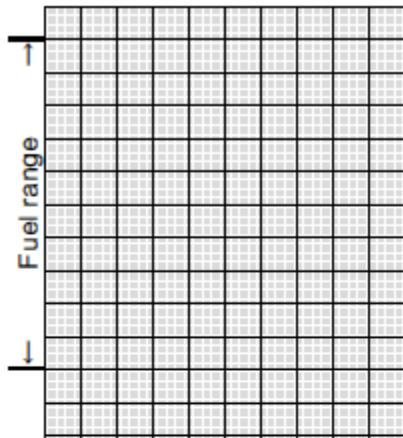

About 3.9 hours after SCRAM

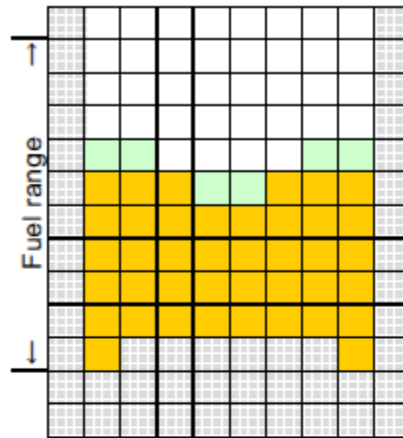

About 5.0 hours after SCRAM

Degree of fuel damage

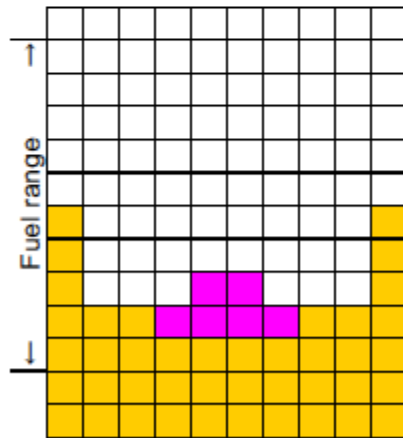
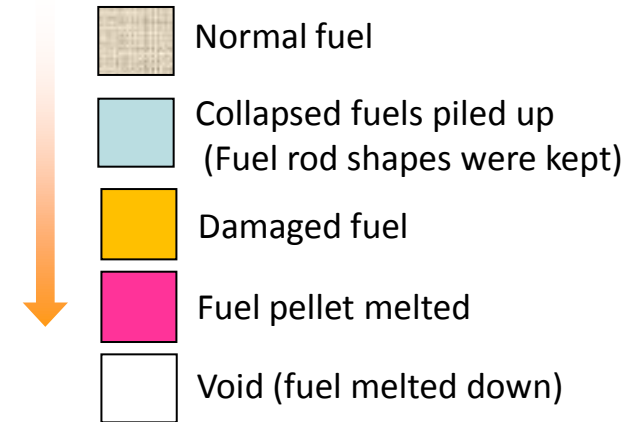

About 11.5 hours after SCRAM

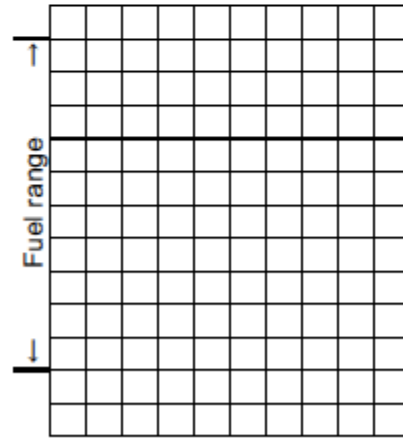

About 12.0 hours after SCRAM

- Melting starts from the central part of the core.
- In 12 hours after scram, most part of the core fell down to the RPV bottom.

Estimated Parameters in Unit 1

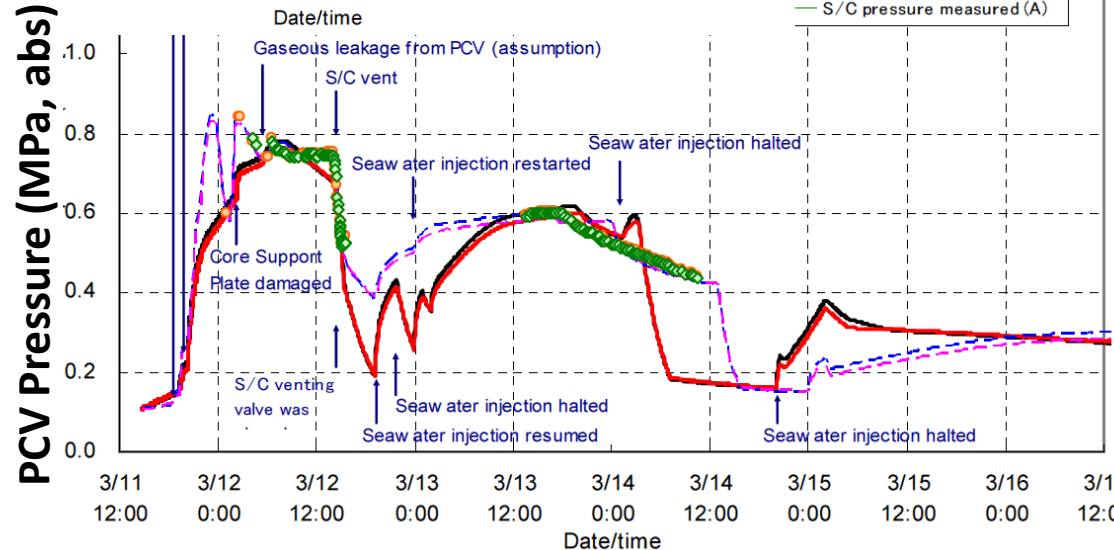
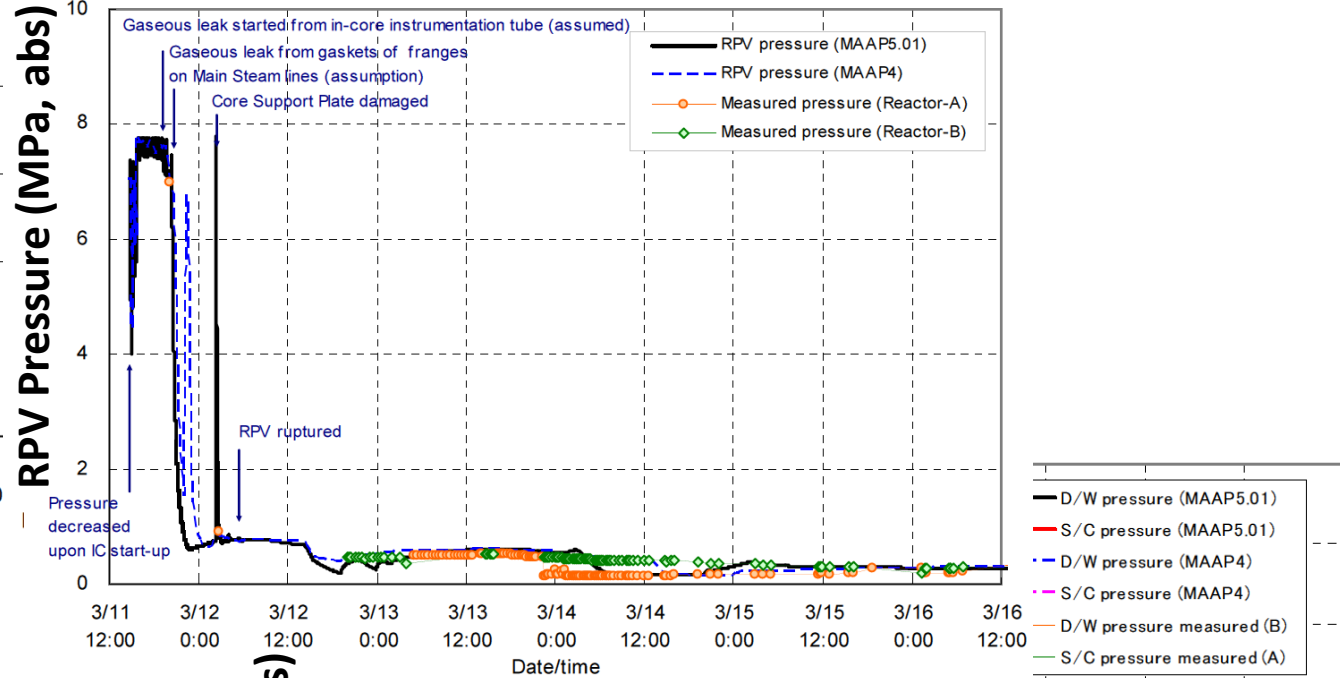
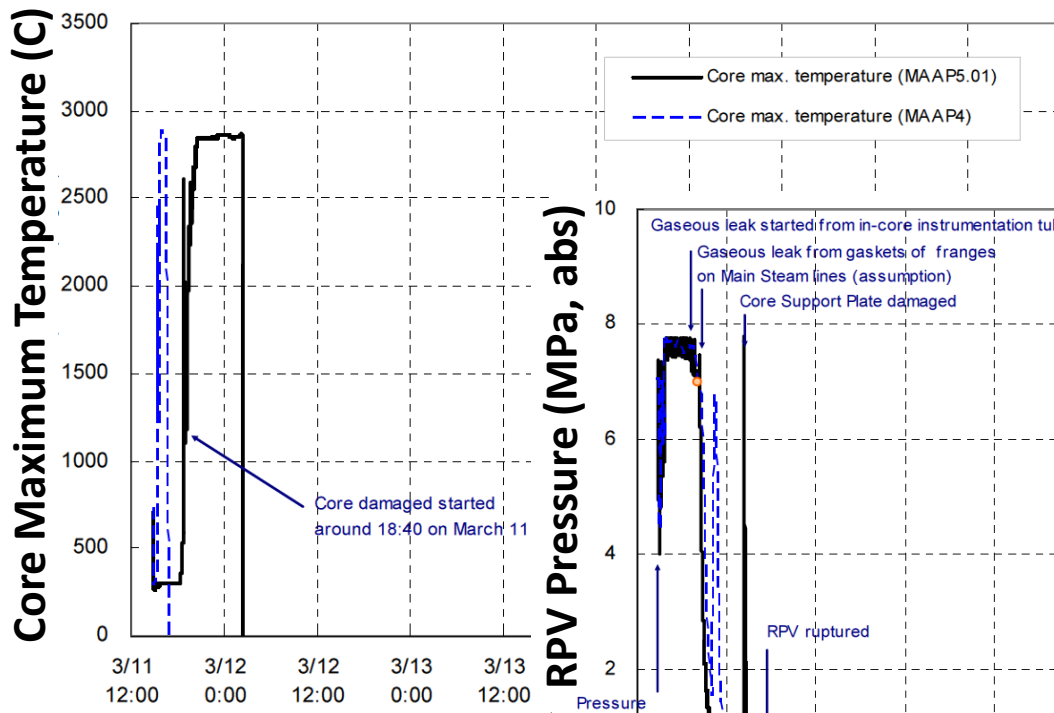

Some measure values used for model justification are also shown.

Macroscopic Balance between Decay Heat and Heat Removal in Unit 1

- Total decay heat before sea water injection greatly exceeds the amount of heat which reactor water and structural materials could absorb.
- Oxidation reaction of Zr provides additional heat to promote the core damage.
- All molten core moved to RPV bottom and they damaged RPV and run down to PCV.

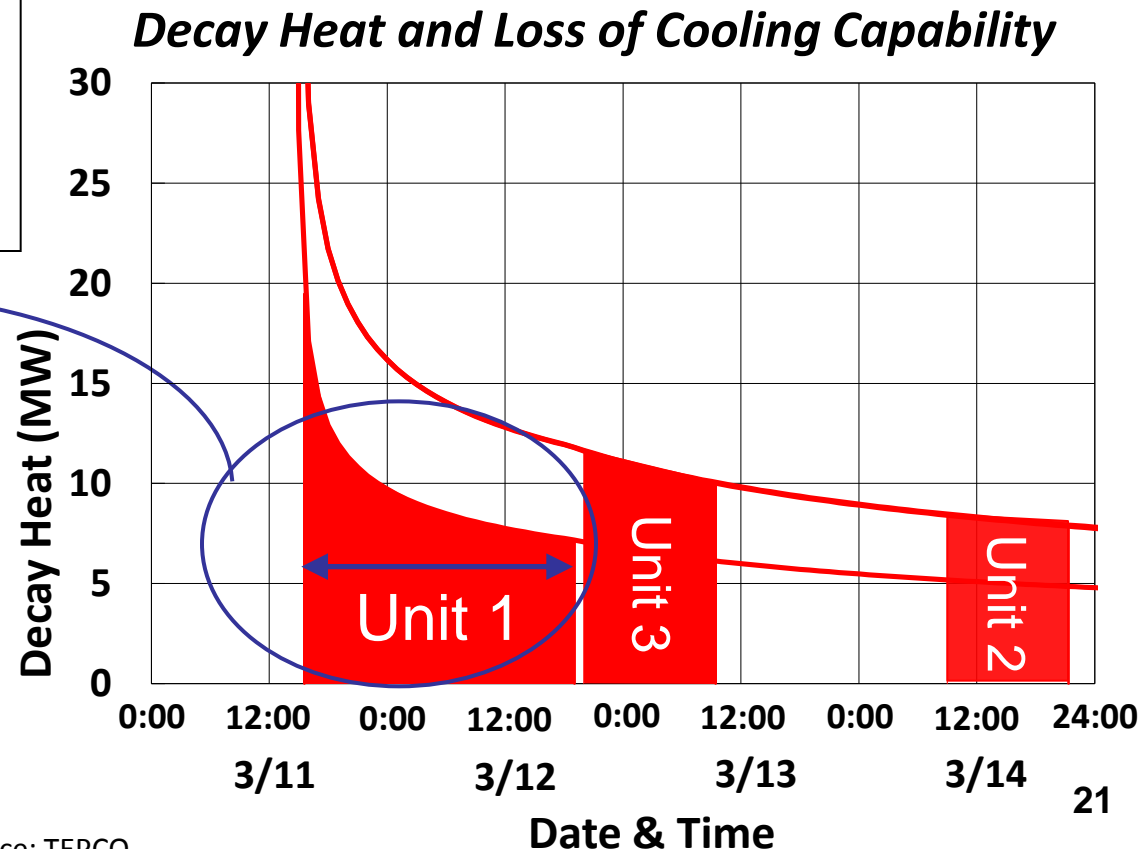
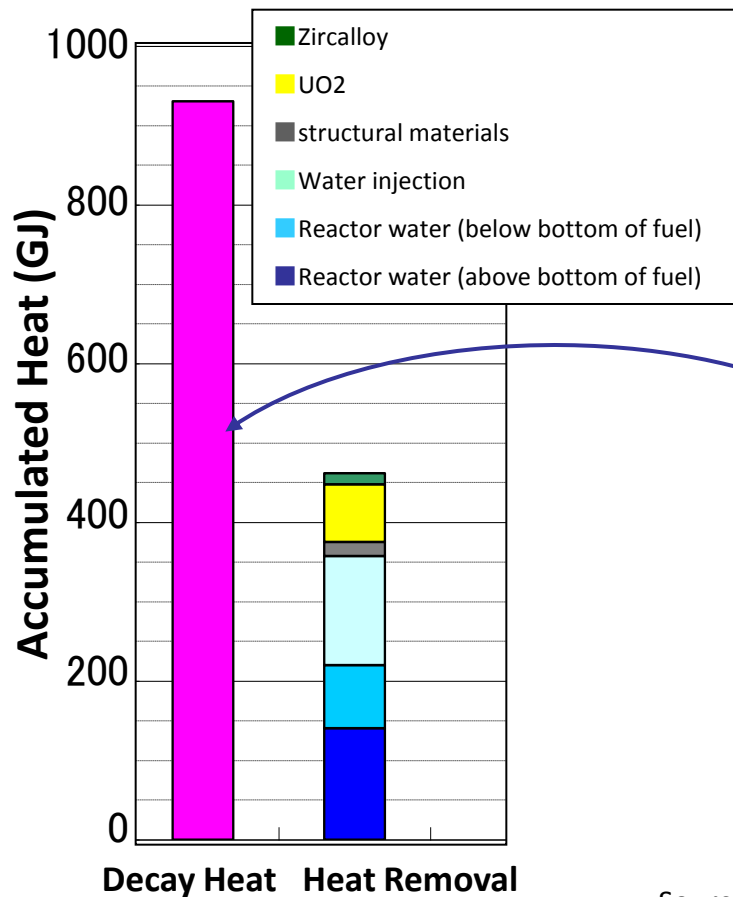

Summary of Core Damage in Unit 1

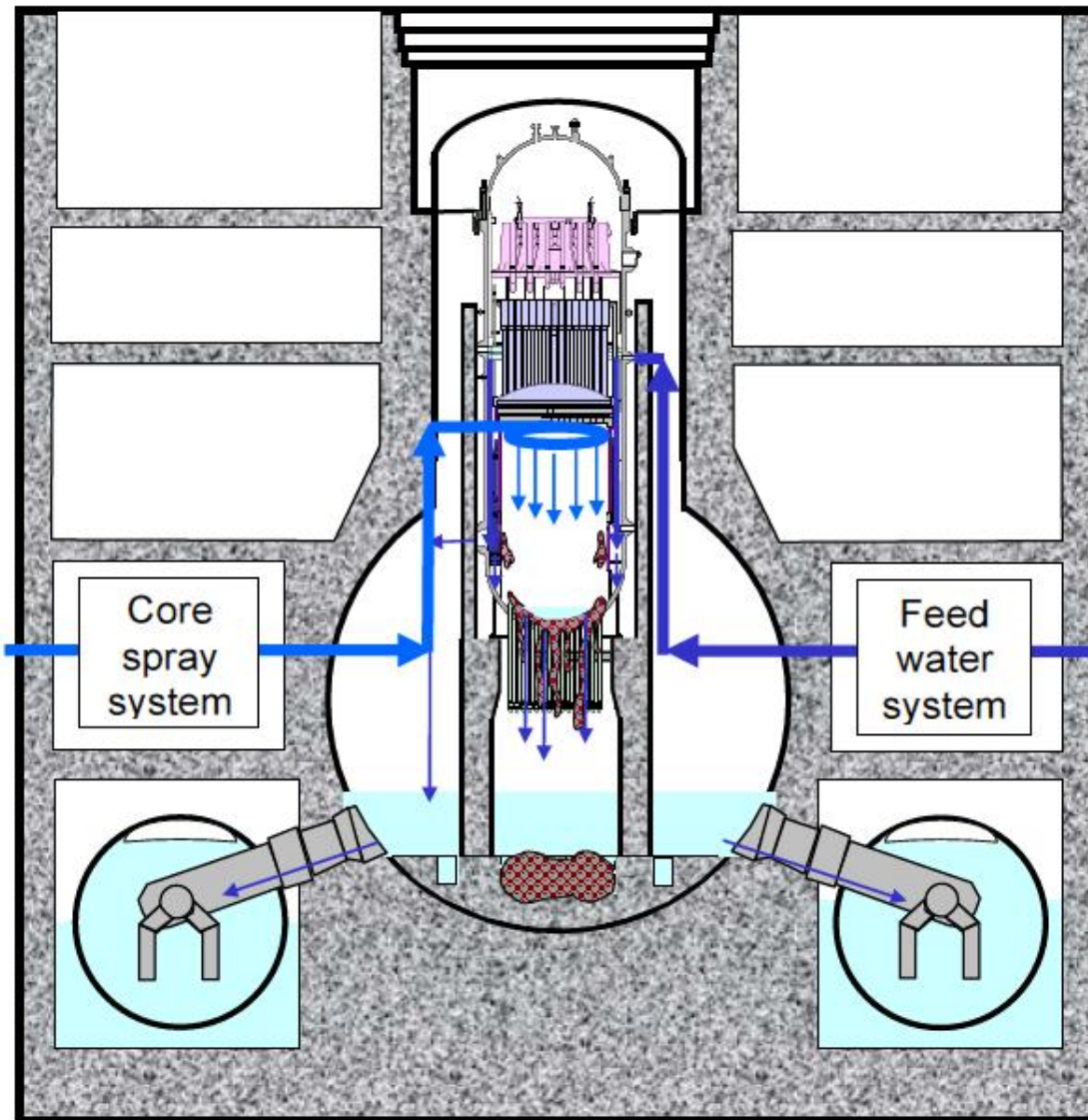

- Severe Accident code analysis indicates;

All fuel rods were melted and relocated to the RPV bottom. Considerable amount of fuel dropped to the PCV bottom.

- **Almost all fuel dropped to the PCV bottom, is in contact with water, and is cooled.**
- **Currently water is injected to the RPV via the feed water piping and core spray piping. Temperature of the RPV bottom and the PCV is stable well below 100 C.**

MCCI: Molten Core Concrete Interaction in Unit 1

Estimated Ablation Depth

- ✓ MAAP/DECOMP code
0.65 m
- ✓ COCO code
0.45 m : Basement
0.38 m : Side Wall

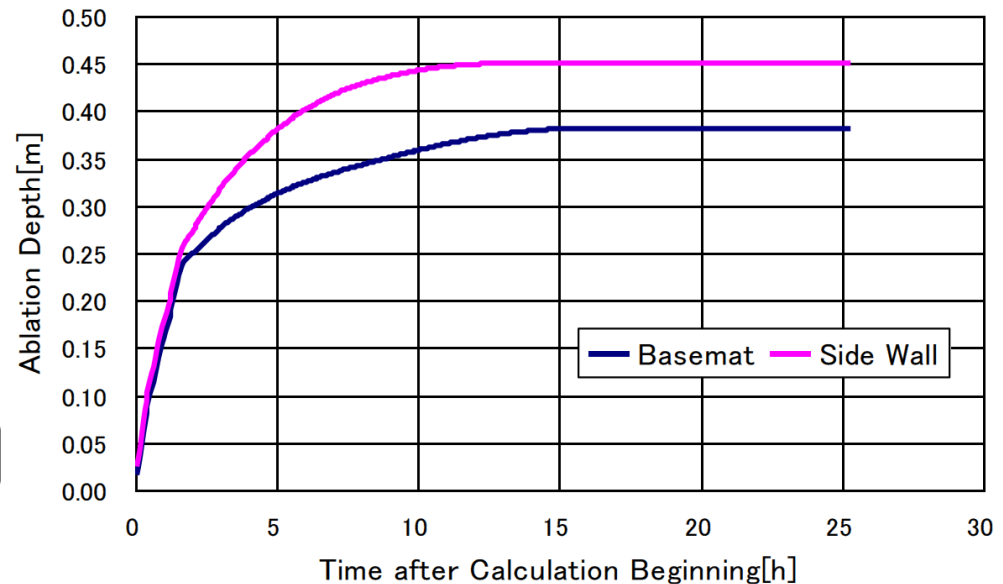
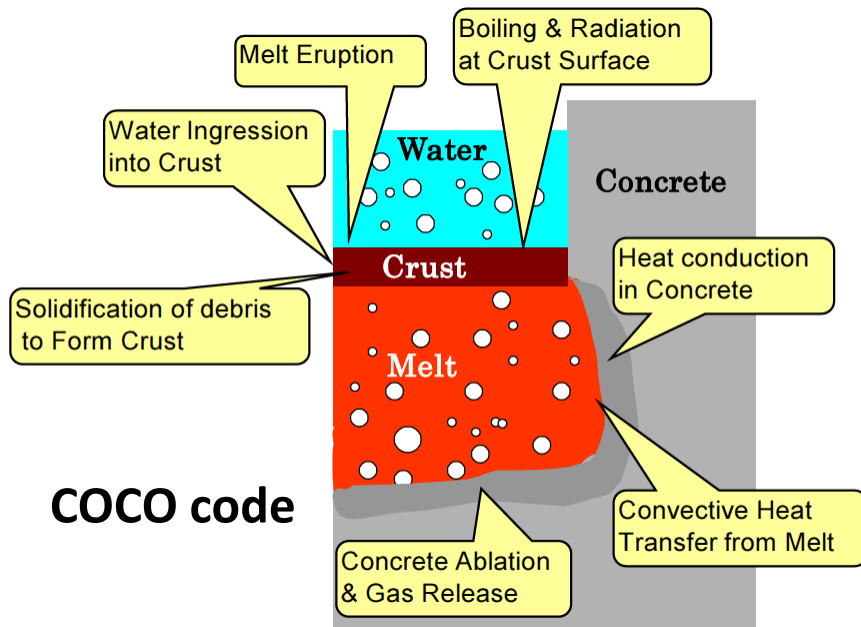
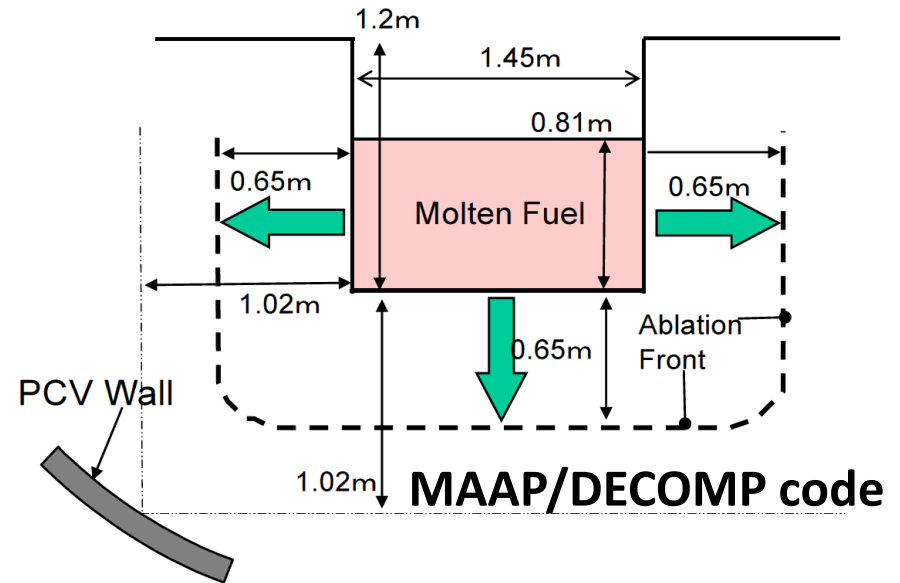

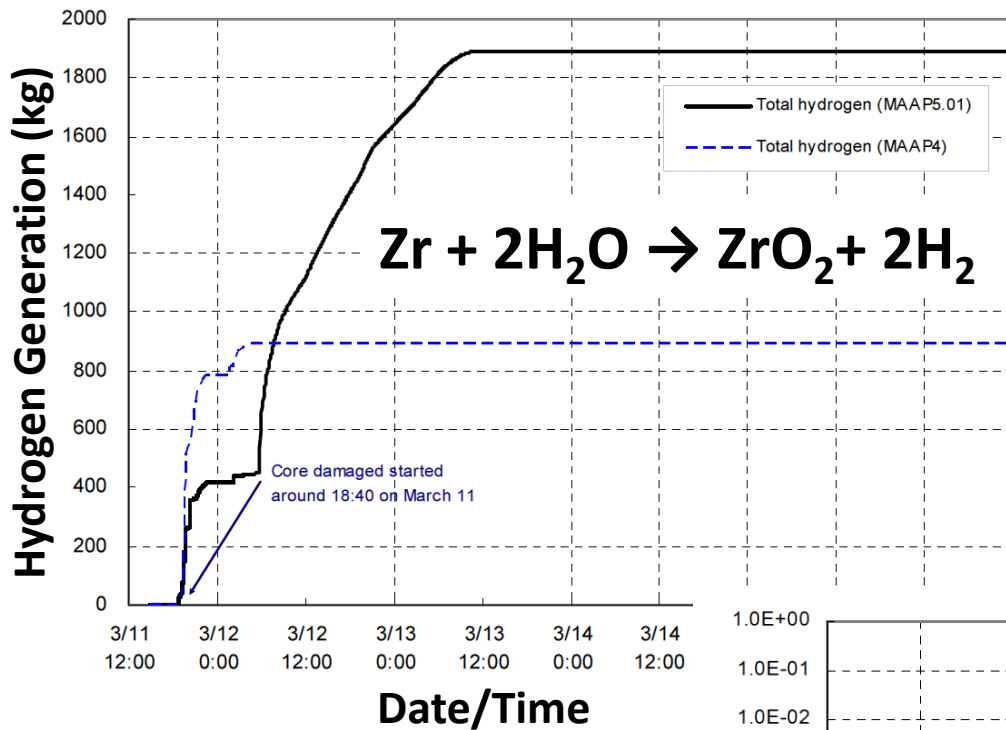

Generation of Hydrogen in Unit 1

Zr-H₂O reaction at high temperature is main source of H₂.

Release Rates of Fission Products in Various Chemical Forms in Unit 1

FP Release Ratio in log scale

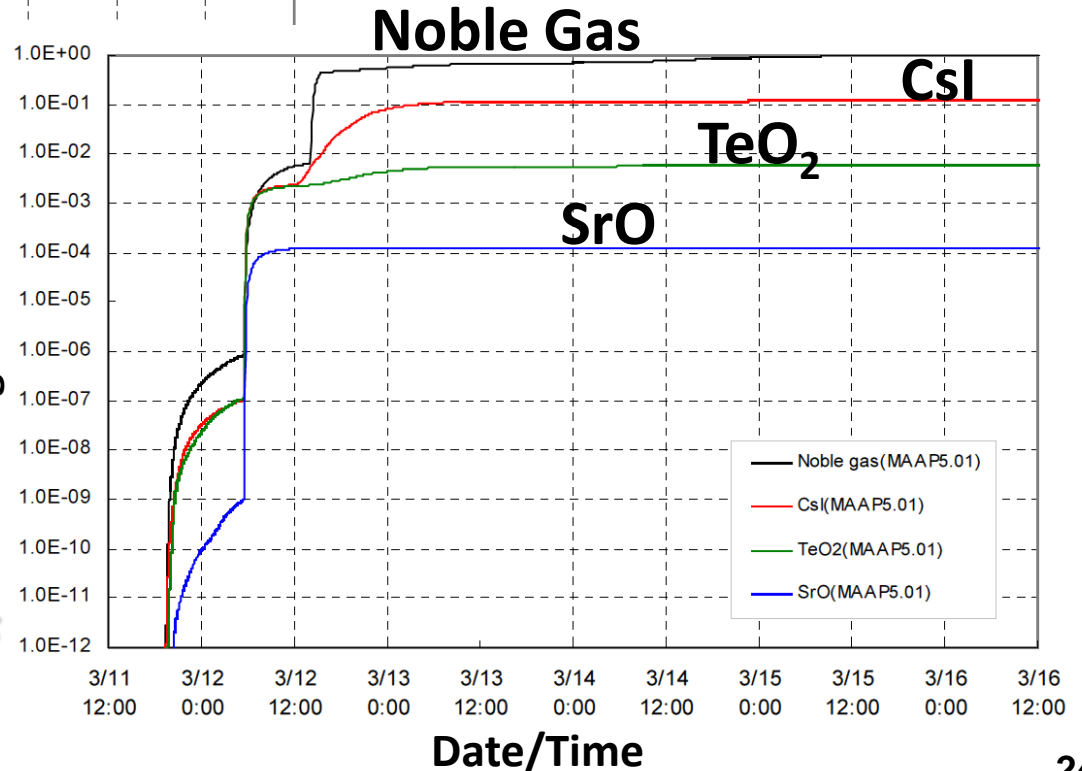

Location of Gas Leak from RPV to PCV in Unit 1

- Possible paths of gaseous leakage from the reactor vessel to the D/W are the in-core instrumentation dry tube or the main steam line flange gasket.
- The in-core instrumentation dry tube can be damaged when fuel temperatures are elevated.
- The main steam line flange gasket may lose its airtightness at temperature of about 450 C.

SRM : Source Range Monitor
IRM : Intermediate Range Monitor
TIP : Travelling In-core Probe

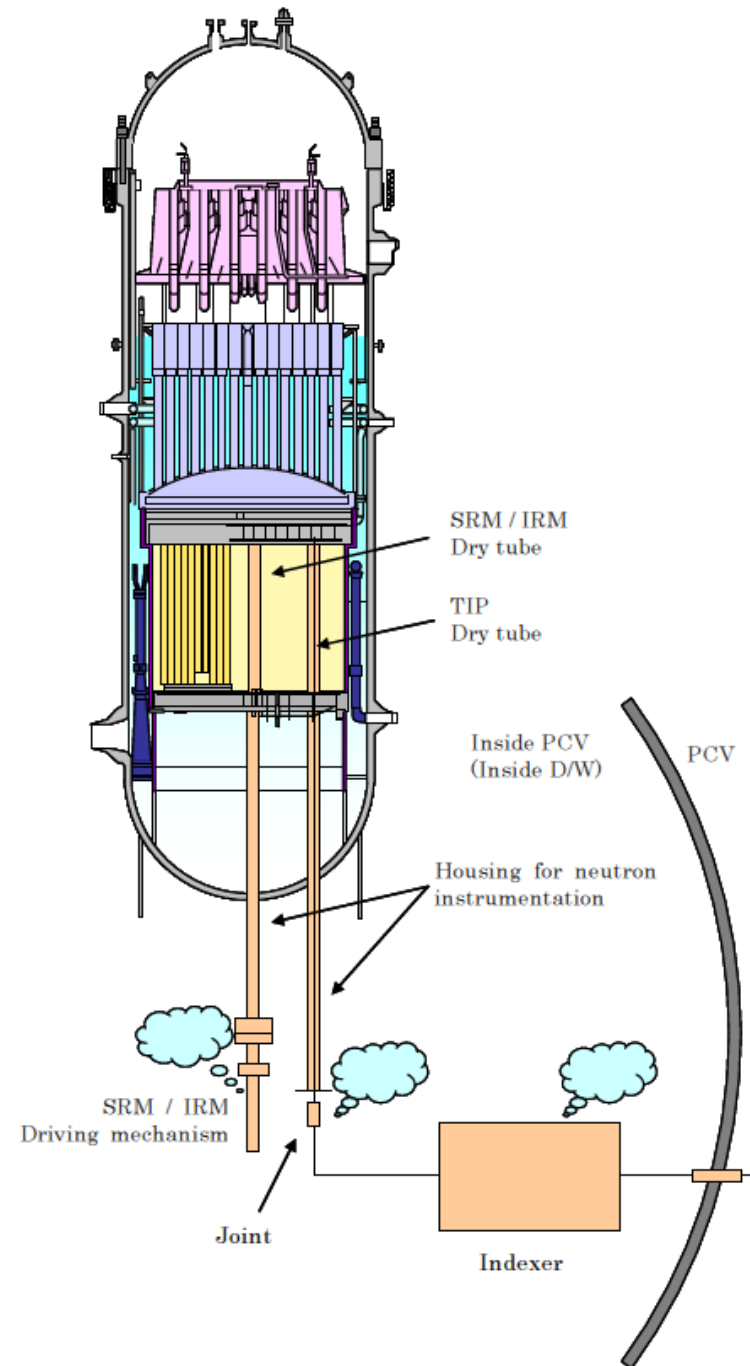

Location of Possible Gas Release from Mark-I PCV to the Reactor Building

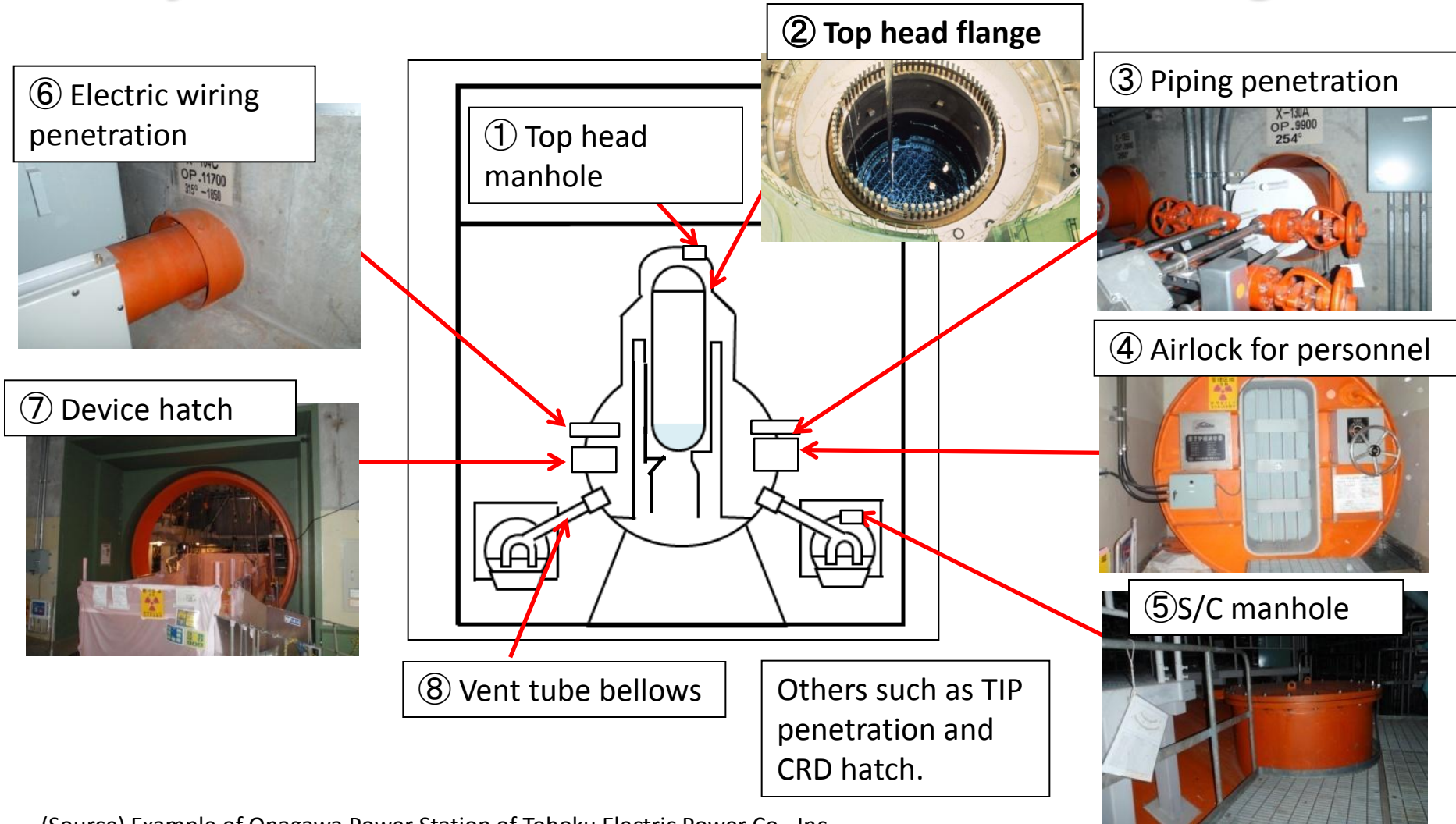

(Source) Example of Onagawa Power Station of Tohoku Electric Power Co., Inc.
(The photo of the top flange is from Tokyo Electric Power Co., Inc.)

Hydrogen Explosion in Unit 1 at 15:36 on March 12, 2011

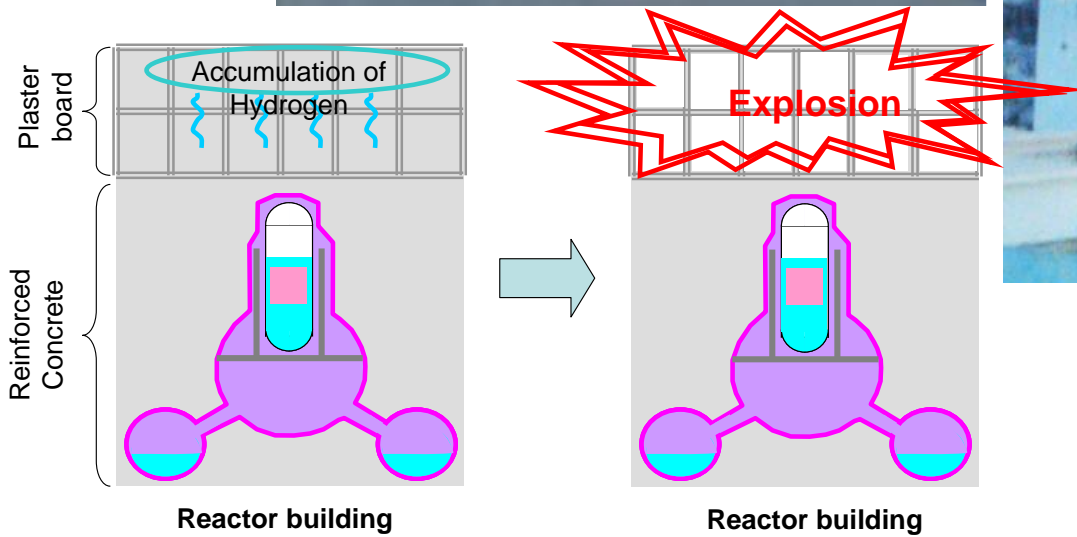
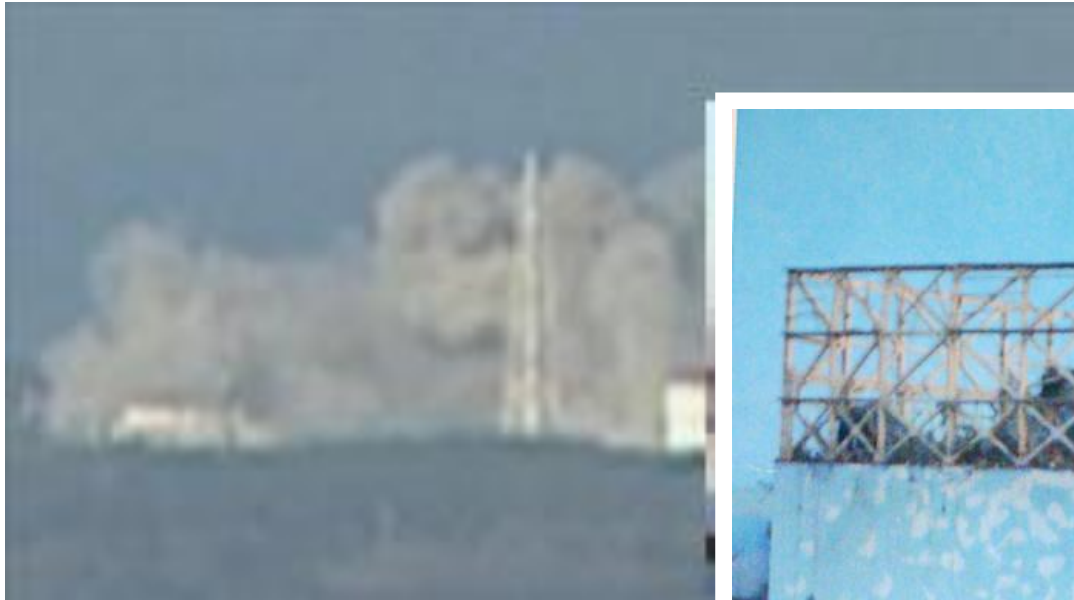

Fundamental Safety Functions for Light Water Reactors

Shutting Down by interrupting fission chain reaction through insertion of control rods

Cooling Down the fuels through continuous water injection and circulation

Confining radioactive materials inside the boundary (RPV and PCV)

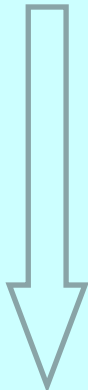
- 
- 1. High-pressure Coolant Injection**
 - 2. Depressurization**
 - 3. Low-pressure Coolant Injection**
 - 4. Heat Removal to Ultimate Heat Sink (Ocean)**
- 

Schematic System Diagram in Unit 2 after the Tsunami

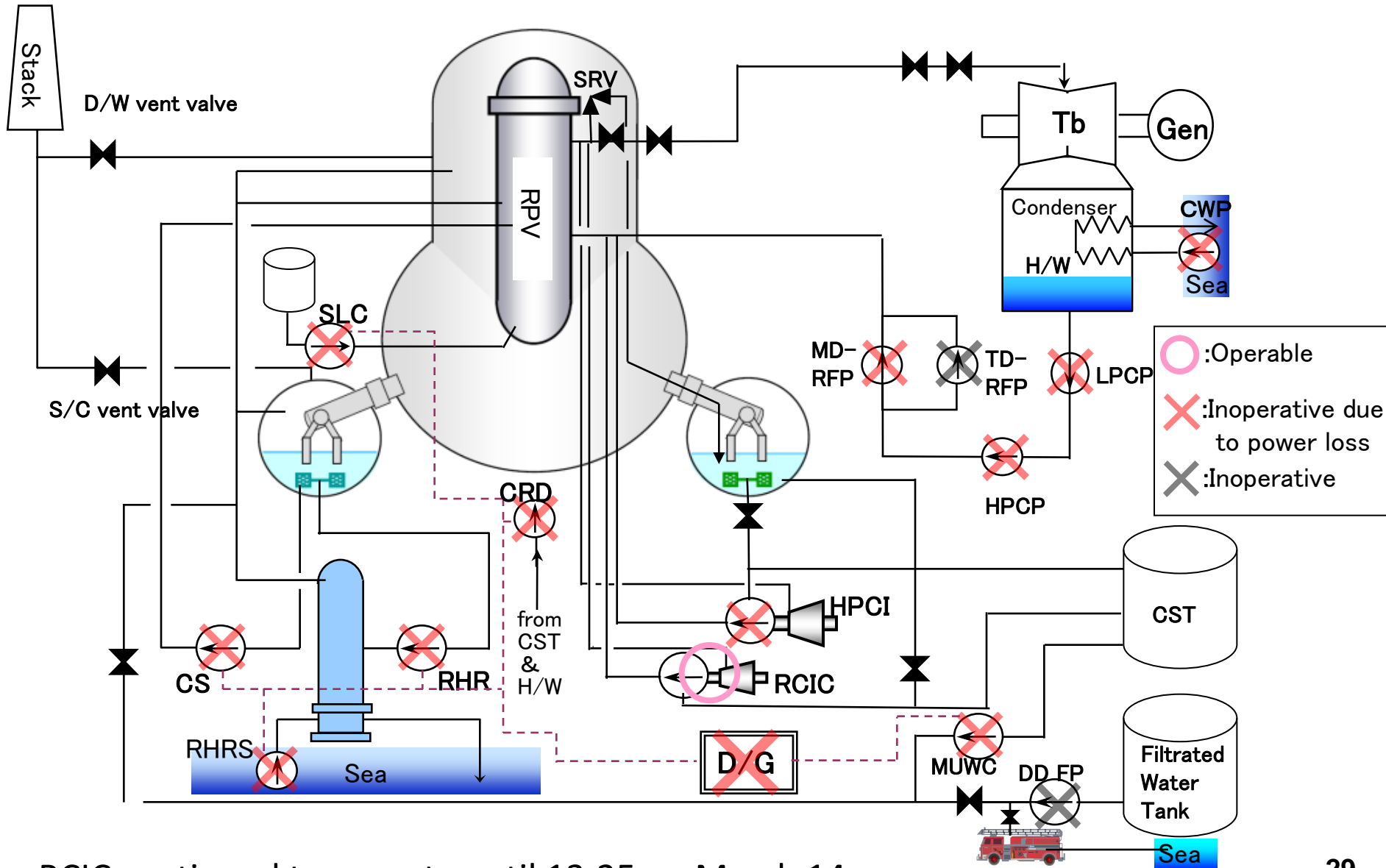

RCIC continued to operate until 13:25 on March 14.

Schematic System Diagram in Unit 3 after the Tsunami

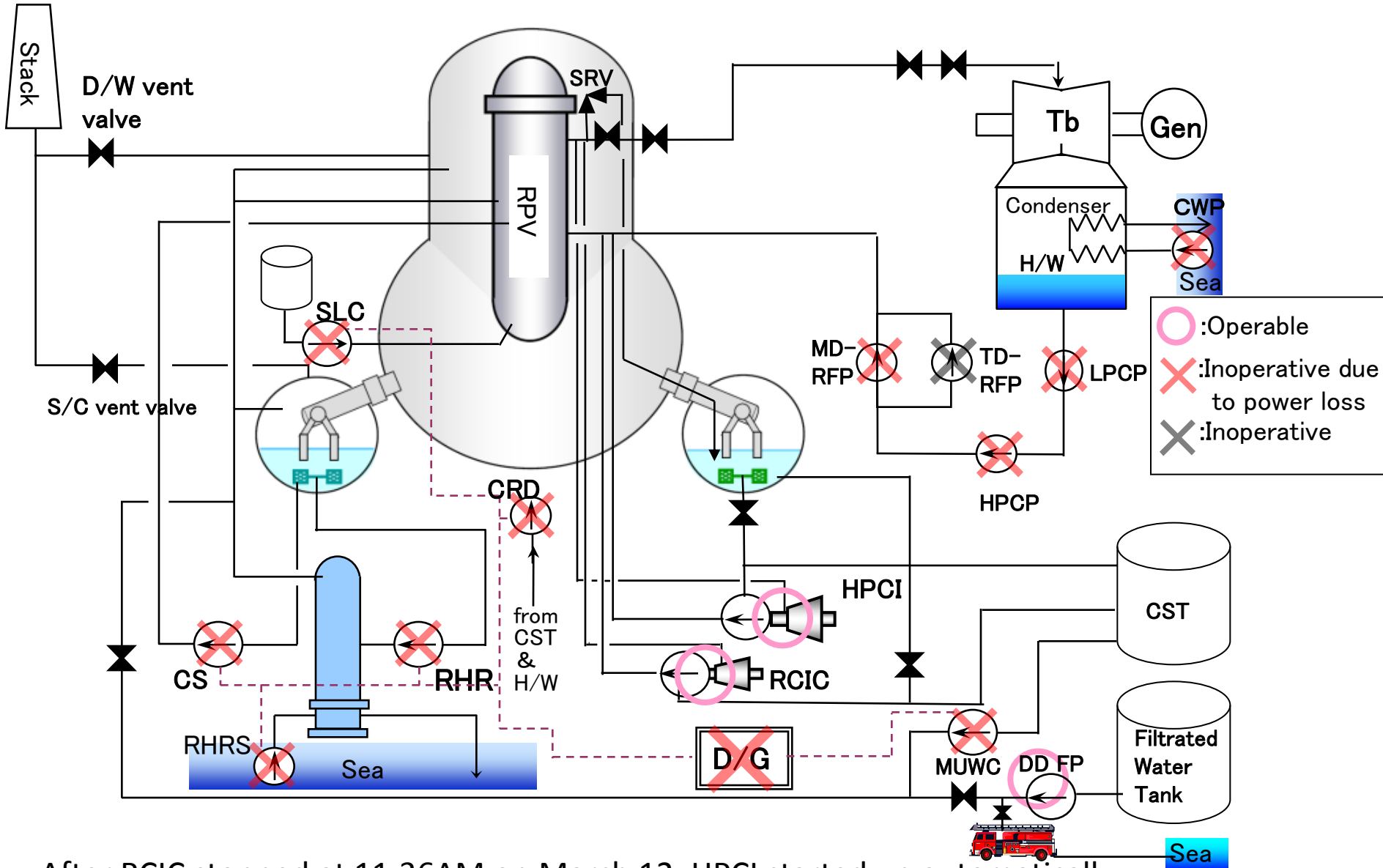

After RCIC stopped at 11:36AM on March 12, HPCI started up automatically. Batteries ran out, and HPCI stopped by 2:42AM on March 13.

High-pressure Coolant Injection

Water is put into the high-pressure reactor pressure vessel to cool the reactor core and maintain water levels.

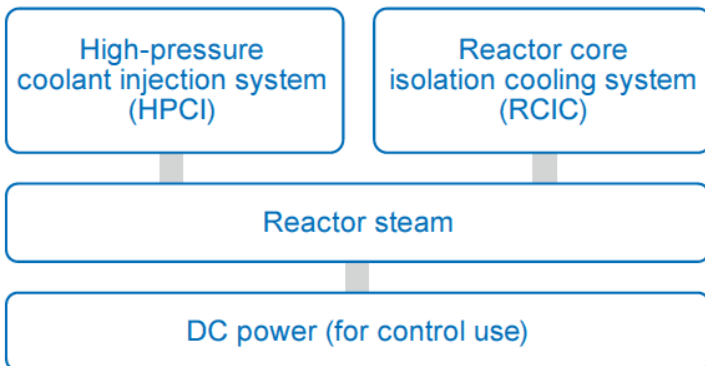
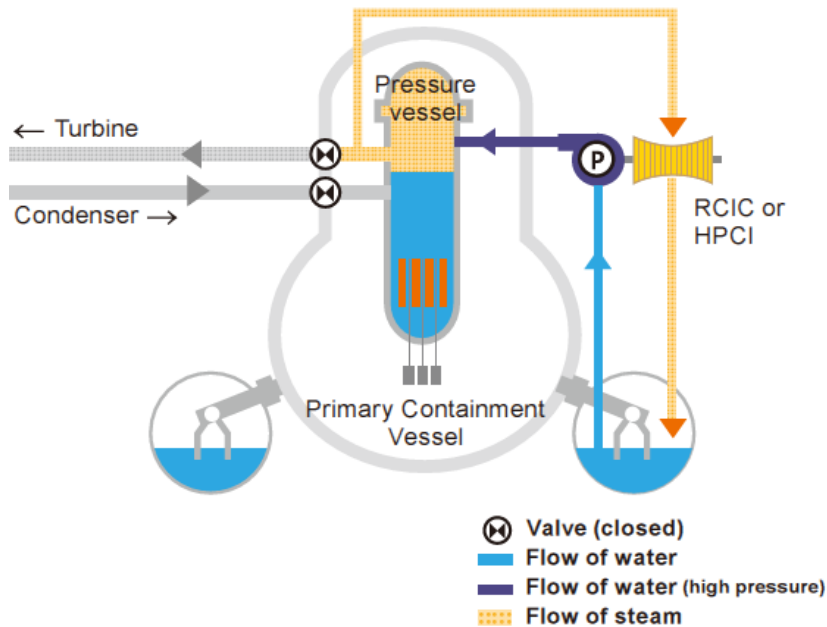

Depressurization

Lower the pressure of the pressure vessel to enable low-pressure coolant injection and heat removal.

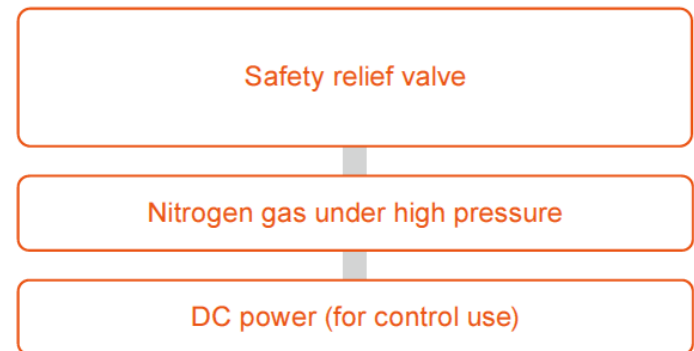
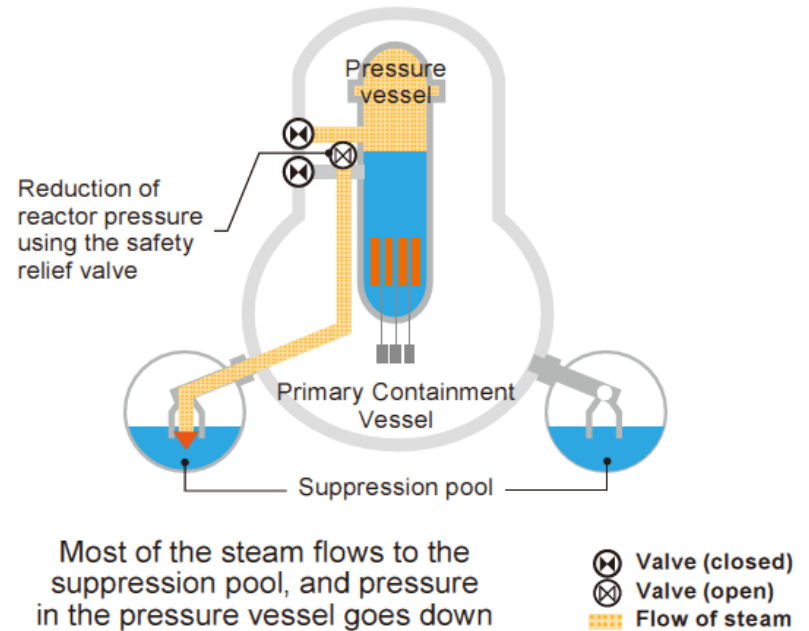

Unit 3



Hydrogen Explosion on 11 AM, March 14



Source: TEPCO

Unit 2

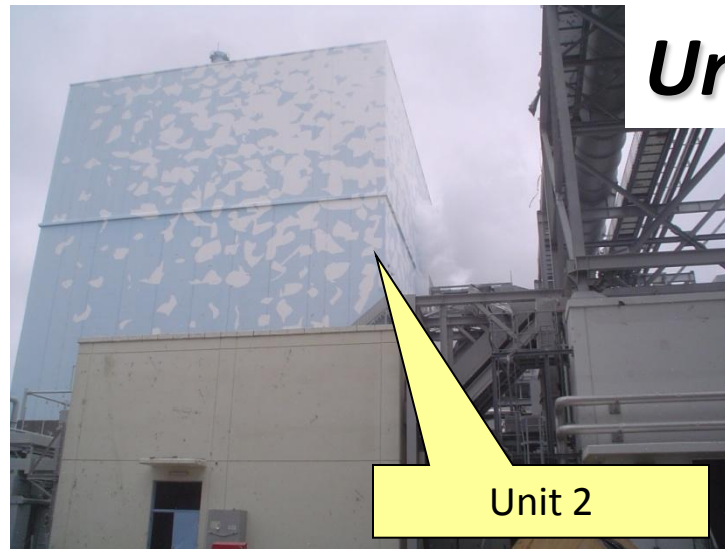

Unit 4

Explosion at on 6 AM, March 15



Unit 3

Unit 4

Summary of Core Damage in Unit 2

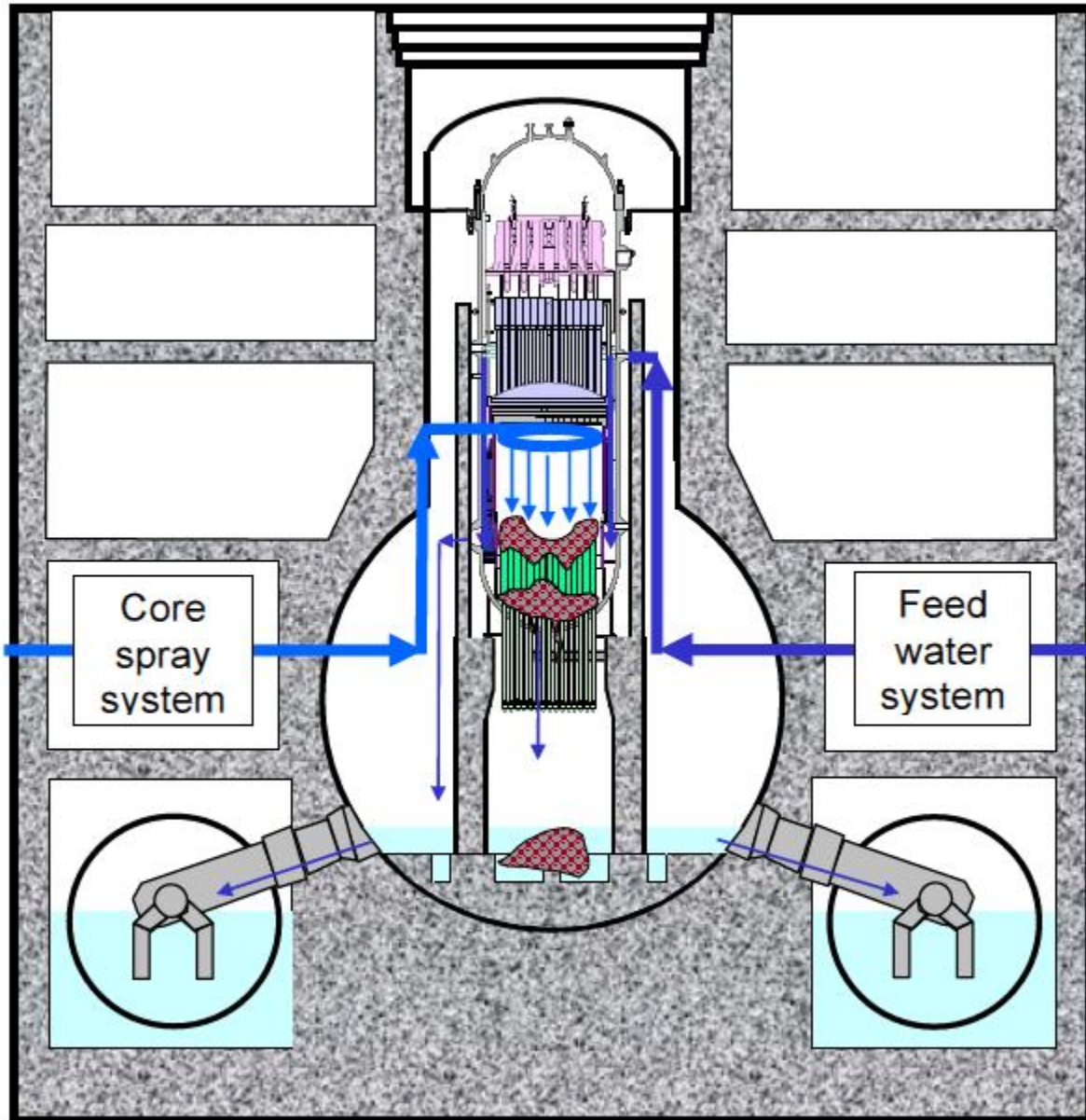

By investigations using an endoscope system, it was confirmed that:

- Water level in PCV is approx. 60 cm,
- Water temperature is approx. 50°C, and
- Dose rate of gas phase is 73 Sv/h.

<Industrial endoscope of 20m>

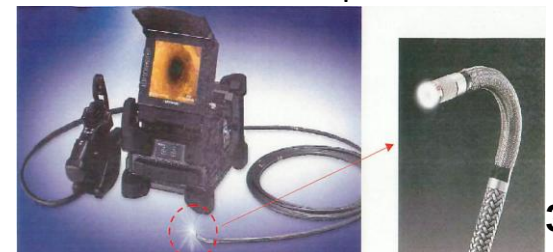





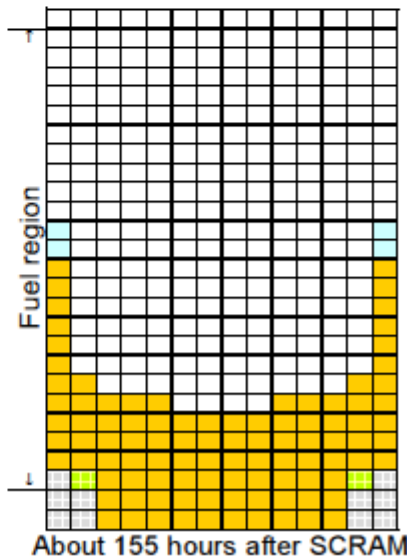
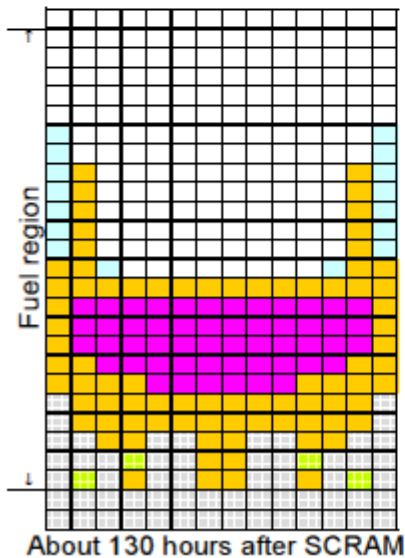
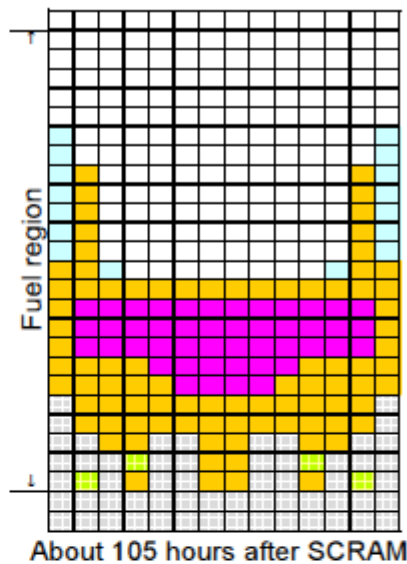
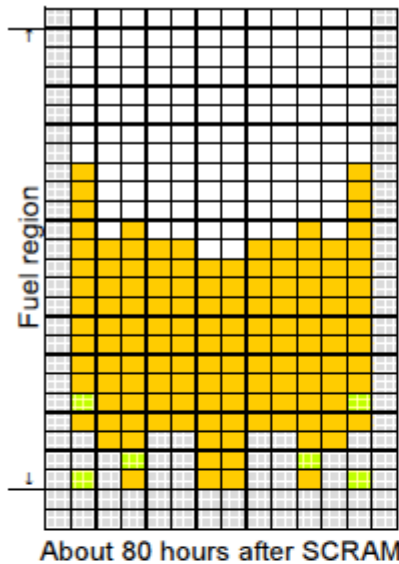

Estimated Core Damage in Unit 2

- Simulation Results by the MAAP code -



Degree of Fuel Damage

-  Normal fuel
-  Collapsed fuels piled up
(Fuel rod shapes were kept)
-  Fuel rod diameters increased due to molten fuel flowing down on their surfaces and solidifying there
-  Fuel rod diameters further increased and blocked the downward flowing path
-  Molten core pool formed
-  Void (fuel melted down)

Summary of Core Damage in Unit 3

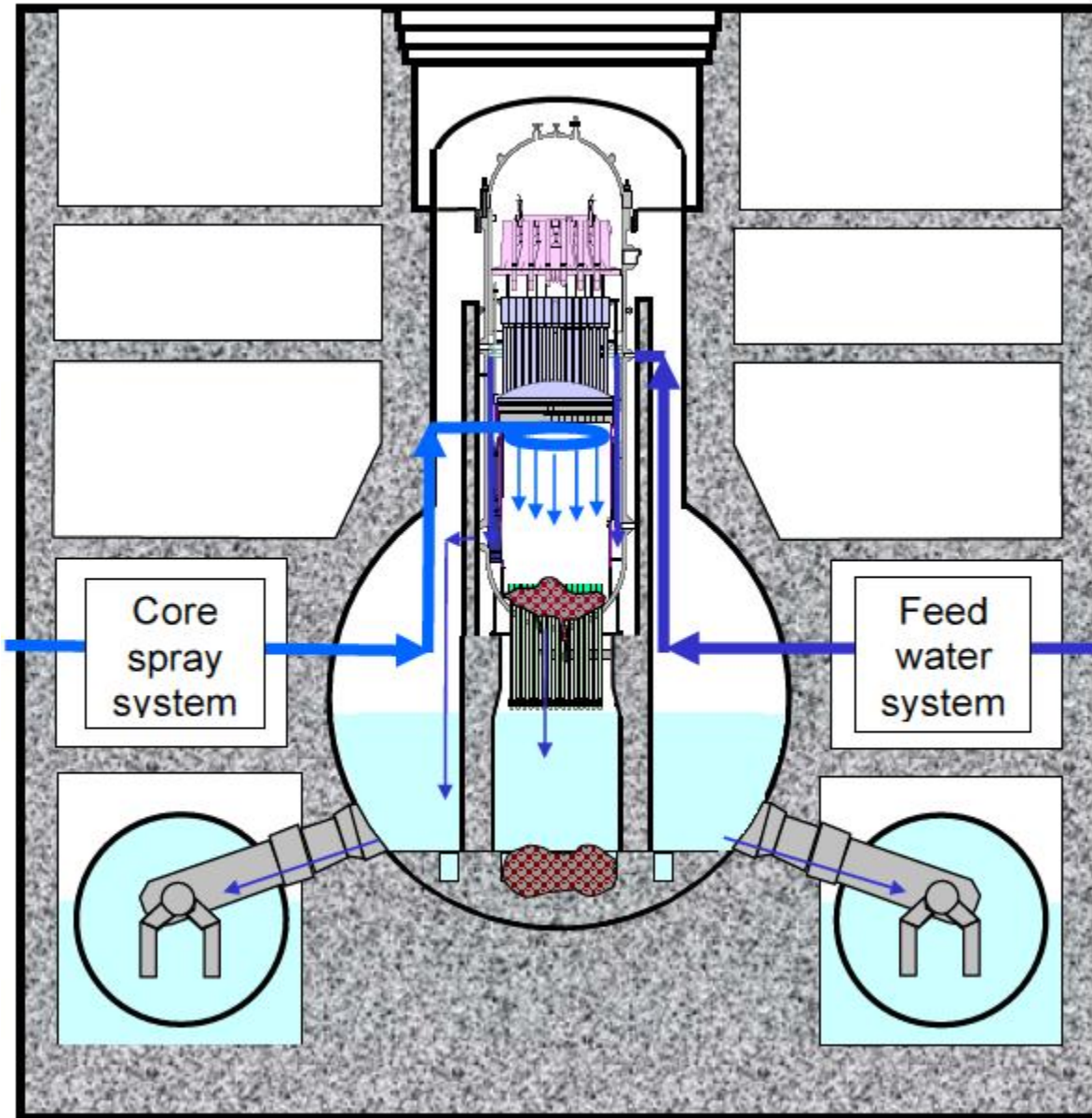





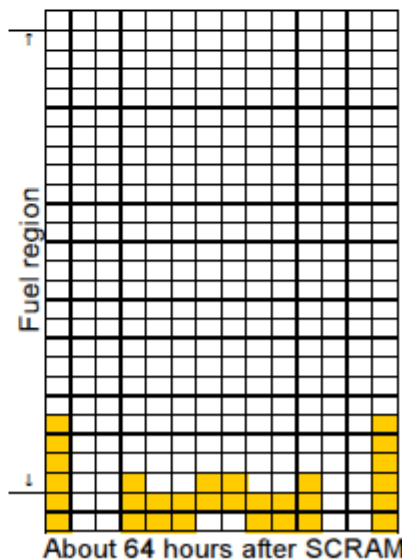
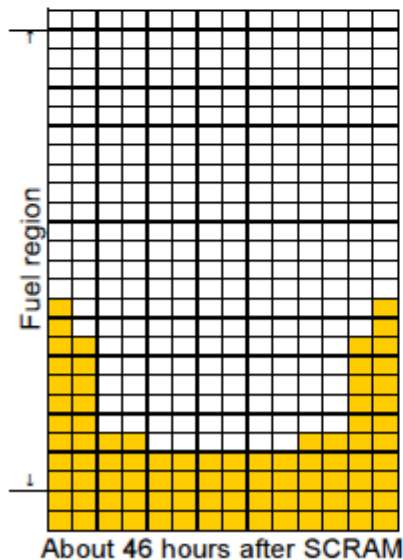
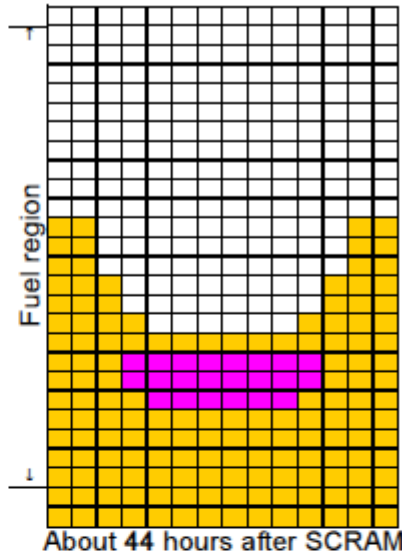
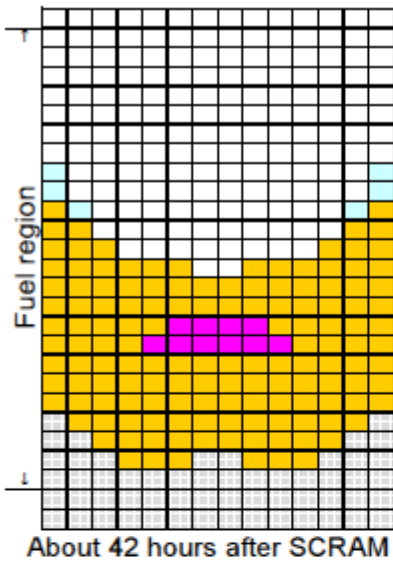

- It was possible to control the RCIC and HPCI and continue cooling, as batteries can be used.
- After RCIC stopped at 11:36 on March 12, HPCI started up automatically.
- At 20:00 on March 12, reactor pressure fell below HPCI design condition 1MPag to about 0.8 MPag. (No cooling water was injected into the reactor after that time.)
- Batteries ran out, and HPCI stopped by 2:42 on March 13.
- A hydrogen explosion occurred in the reactor building at 11:01 on March 14.

Estimated Core Damage in Unit 3

- Simulation Results by the MAAP code -



Degree of Fuel Damage

-  Normal fuel
-  Collapsed fuels piled up
(Fuel rod shapes were kept)
-  Fuel rod diameters increased due to molten fuel flowing down on their surfaces and solidifying there
-  Fuel rod diameters further increased and blocked the downward flowing path
-  Molten core pool formed
-  Void (fuel melted down)

Amount of Released Radioactive Material to determine INES Rating (April 11, 2011)

	Estimated release from Fukushima Daiichi		Release from Chernobyl
	by NISA	by Nuclear Safety Commission	
I-131 (a)	$1.3 \times 10^{17} \text{Bq}$	$1.5 \times 10^{17} \text{Bq}$	$1.8 \times 10^{18} \text{Bq}$
Cs-137	$6.0 \times 10^{15} \text{Bq}$	$1.2 \times 10^{16} \text{Bq}$	$8.5 \times 10^{16} \text{Bq}$
Iodine value conversion (b)	$2.4 \times 10^{17} \text{Bq}$	$4.8 \times 10^{17} \text{Bq}$	$3.4 \times 10^{18} \text{Bq}$
(a) + (b)	$3.7 \times 10^{17} \text{Bq}$	$6.3 \times 10^{17} \text{Bq}$	$5.2 \times 10^{18} \text{Bq}$

INES level 7 > 10^{16}Bq Iodine equivalent

INES : International Nuclear Event Scale

INES Manual (2008) co-sponsored by IAEA and OECD/NEA

International Nuclear Event Scale (INES)

	<i>Off-site Impact</i>	<i>On-site Impact</i>	<i>Defense-in-Depth Degradation</i>
7	Major release		
6	Significant release		
5	Limited release	Severe damage	
4	Minor release	Significant damage / Fatal exposure of worker	
3	Very small release	Severe spread of contamination / health effects to worker	Near accident
2		Significant spread of contamination / overexposure of worker	Significant failure
1			Beyond Operation limit
0			
Out of scale			

Released Amount of Radio-active Nuclide Estimated by the MELCORE code

(Bq)

Nuclide	Unit 1	Unit 2	Unit 3
Xe-133	1.6×10^{18}	3.3×10^{18}	4.3×10^{18}
I-131	4.8×10^{16}	1.9×10^{17}	$1.4 \times 10^{16} \sim 1.0 \times 10^{17}$
Cs-134	1.2×10^{15}	7.1×10^{15}	$2.22 \times 10^{13} \sim 6.7 \times 10^{15}$
Cs-137	9.7×10^{14}	6.3×10^{15}	$1.3 \times 10^{12} \sim 5.8 \times 10^{15}$
Sr-89	6.9×10^{14}	1.2×10^{16}	$4.5 \times 10^{13} \sim 2.2 \times 10^{14}$
Ba-140	1.0×10^{15}	1.9×10^{16}	$2.7 \times 10^{14} \sim 3.55 \times 10^{14}$
Te-132	4.6×10^{16}	8.3×10^{16}	$2.8 \times 10^{16} \sim 3.3 \times 10^{16}$
Ru-103	8.82×10^7	6.8×10^{10}	$3.2 \times 10^9 \sim 4.0 \times 10^9$
Pu-241	6.3×10^6	3.0×10^8	$3.0 \times 10^5 \sim 2.6 \times 10^7$
Cm-242	2.4×10^8	7.51×10^9	$2.1 \times 10^9 \sim 6.7 \times 10^9$

Groups of Radionuclides from Nuclear Fuel

<i>Group #</i>	<i>Designation</i>	<i>Elements</i>
1	Noble Gases	Xe, Kr
2	Halogens	I, Br
3	Alkali Metals	Cs, Rb
4	Tellurium Group	Te, Sb, Se
5	Barium, Strontium	Ba, Sr
6	Noble Metals	Ru, Rh, Pd, Mo, Tc, Co
7	Lanthanides	La, Zr, Nd, Eu, Nb, Pm, Pr, Sm, Y, Cm, Am
8	Cerium Group	Ce, Pu, Np

Radionuclides considered Important in the Reactor Safety Study Consequence Analysis (1)

3,200 MWth PWR case

Radionuclides	Half-life [days]	Shutdown inventory [MCi]
1) Noble gases		
⁸⁵ Kr*	3950	0.56
^{85m} Kr*	0.183	24
⁸⁷ Kr*	0.0528	47
⁸⁸ Kr*	0.117	68
¹³³ Xe	5.28	170
¹³⁵ Xe	0.384	34
2) Halogens		
¹³¹ I	8.05	85
¹³² I	0.0958	120
¹³³ I	0.875	170
¹³⁴ I	0.0366	190
¹³⁵ I	0.28	150
3) Alkali metals		
¹³⁴ Cs	750	7.5
¹³⁶ Cs	13	3
¹³⁷ Cs	11000	4.7
⁸⁶ Rb*	18.7	0.026

4) Tellurium group		
¹²⁷ Te*	0.391	5.9
^{127m} Te	109	1.1
¹²⁹ Te*	0.048	31
^{129m} Te	0.34	5.3
^{131m} Te	1.25	13
¹³² Te	3.25	120
¹²⁷ Sb	3.88	6.1
¹²⁹ Sb	0.179	33
5) Barium and strontium group		
⁸⁹ Sr	52.1	94
⁹⁰ Sr	11030	3.7
⁹¹ Sr	0.403	110
¹⁴⁰ Ba	12.8	160

*** Indicates negligible contribution to health effects**

Radionuclides considered Important in the Reactor Safety Study Consequence Analysis (2)

Radionuclides	Half-life [days]	Shutdown inventory [MCi]
6) Noble metals		
⁵⁸ Co*	71	0.78
⁶⁰ Co*	1920	0.29
⁹⁹ Mo	2.8	160
^{99m} Tc*	0.25	140
¹⁰³ Ru	39.5	110
¹⁰⁵ Ru*	0.185	72
¹⁰⁶ Ru	366	25
¹⁰⁵ Rh*	1.5	49

7+8) Lanthanides and cerium group		
⁹⁰ Y*	2.67	3.9
⁹¹ Y	59	120
⁹⁵ Zr	65.2	150
⁹⁷ Zr	0.71	150
⁹⁵ Nb	35	150
¹⁴⁰ La	1.67	160
¹⁴¹ Ce	32.3	150
¹⁴³ Ce*	1.38	130
¹⁴⁴ Ce	284	85
¹⁴³ Pr	13.7	130
¹⁴⁷ Nd*	11.1	60
²³⁹ Np	2.35	1640
²³⁸ Pu	32500	0.057
²³⁹ Pu	8.90E+06	0.021
²⁴⁰ Pu	2.40E+06	0.021
²⁴¹ Pu	5350	3.4
²⁴¹ Am*	1.50E+05	0.0017
²⁴² Cm	163	0.5
²⁴⁴ Cm	6630	0.023

3,200 MWth PWR case

*** Indicates negligible contribution to health effects**

Distribution of CsI and CsOH in Various Location in Unit 1 (MAAP code)

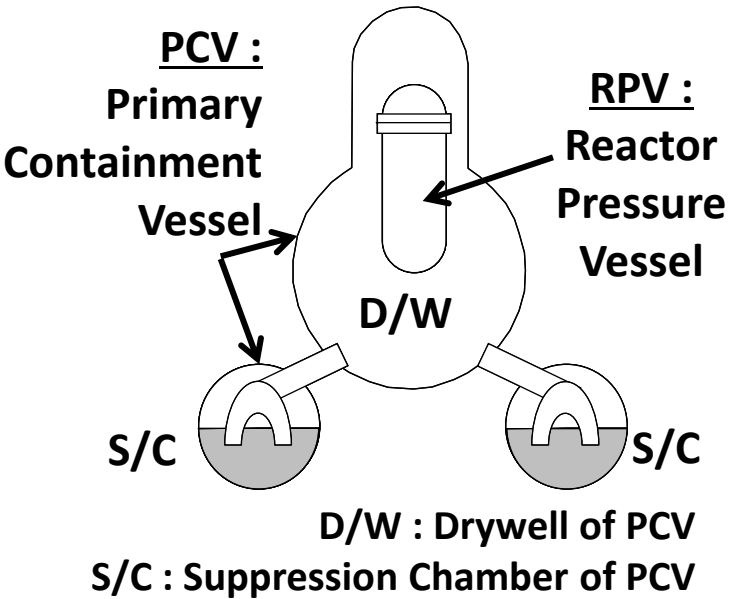
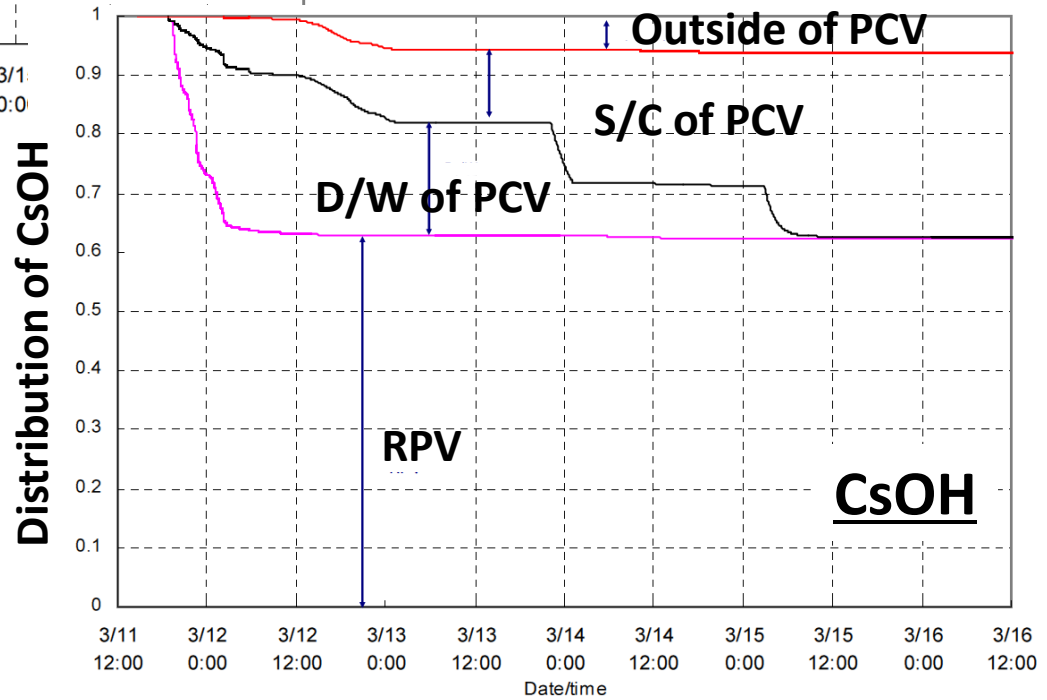
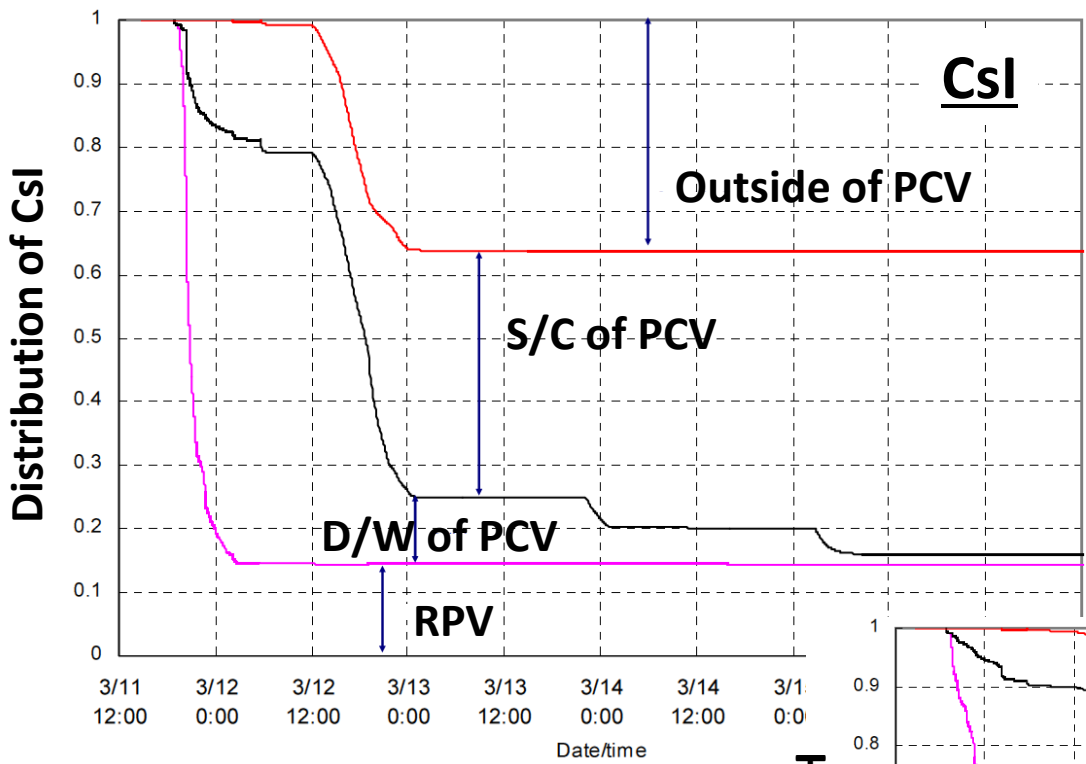

On-site Radiation Monitoring in Fukushima Daiichi Site From March 11 to 17, 2011

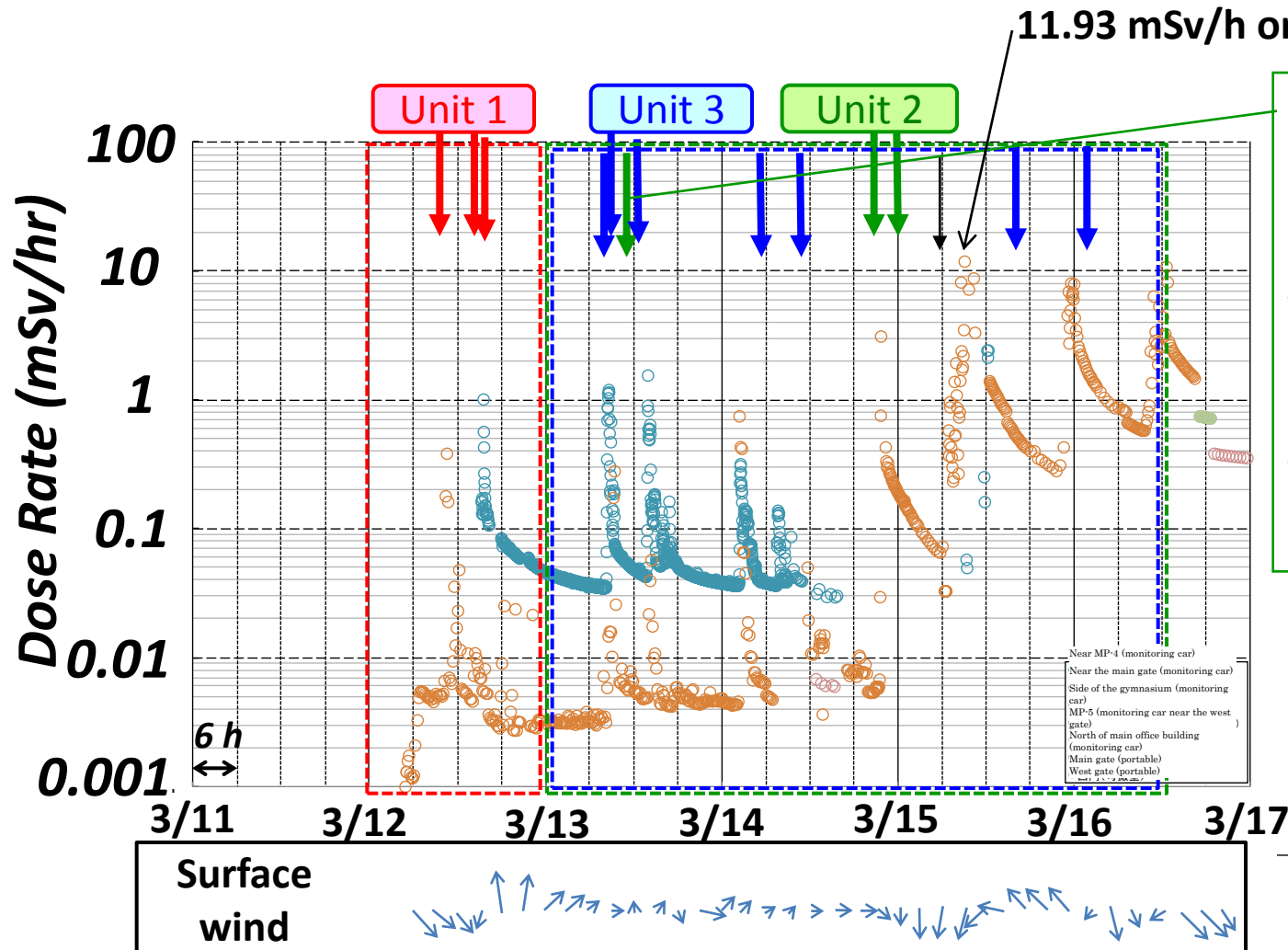

March 13 11:00
Unit 2's large S/C vent valve (AO valve) was opened and open operation of the valves in the PCV vent line other than the rupture disks was completed.

(D/W pressure did not reach to the operation pressure of 0.427MPa for the rupture disk)

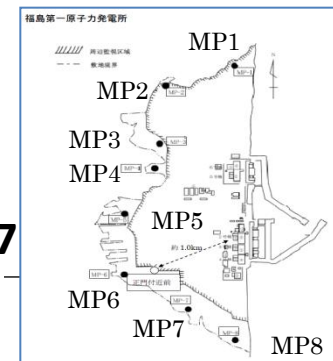

Detection of Neutrons

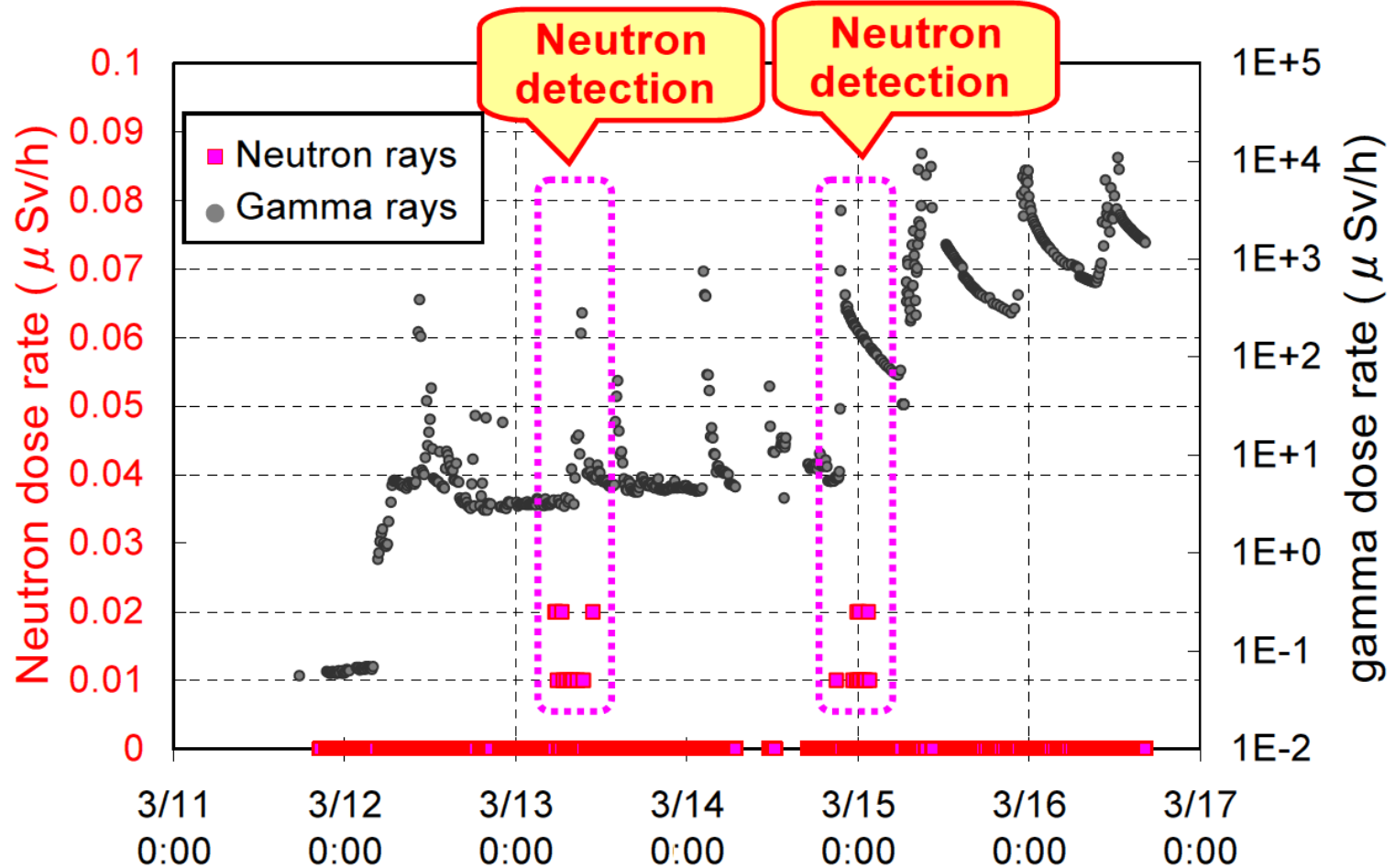

- Neutrons detected in the morning of March 13 and in the night of March 14 were released in the course of fuel melting at Units 3 and 2, respectively.
- Neutrons may have been generated by the spontaneous fission of released actinides.

Radiation Control for Site Workers

Radiation Dose from External and Internal Exposure for Workers in Fukushima Daiichi Nuclear Power Station

3,695 Workers (working from March) and 3,388 Workers (from April) *
have been inspected by July 29, 2011

Radiation Dose (External + Internal): Number of Workers

100mSv ~ 150mSv	:	86
150mSv ~ 200mSv	:	14
200mSv ~ 250mSv	:	2
250mSv ~	:	6
		(309mSv ~ 678mSv)

* out of total workers 3,747(from March) + 3,776 (from April)

Radiation Monitoring at The University of Tokyo From March 15 to 31, 2011

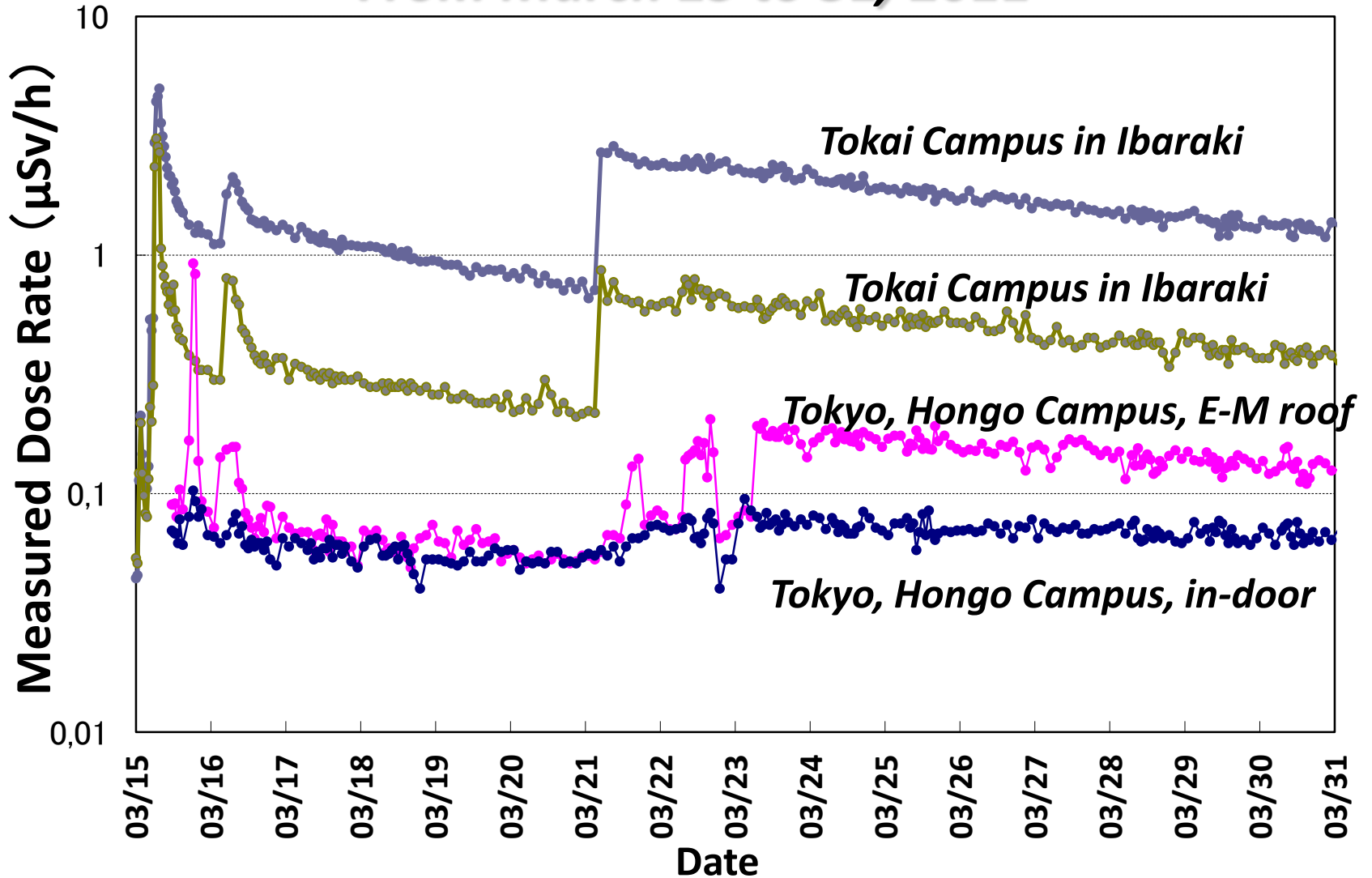

Distance from Fukushima Daiichi NPPs

Ibaraki, Tokai Campus : 110 km

Tokyo, Hongo Campus : 230 km

Radiation Monitoring at The University of Tokyo

From March 15 to May 24, 2011



Monitoring Radiation Dose in Fukushima Prefecture

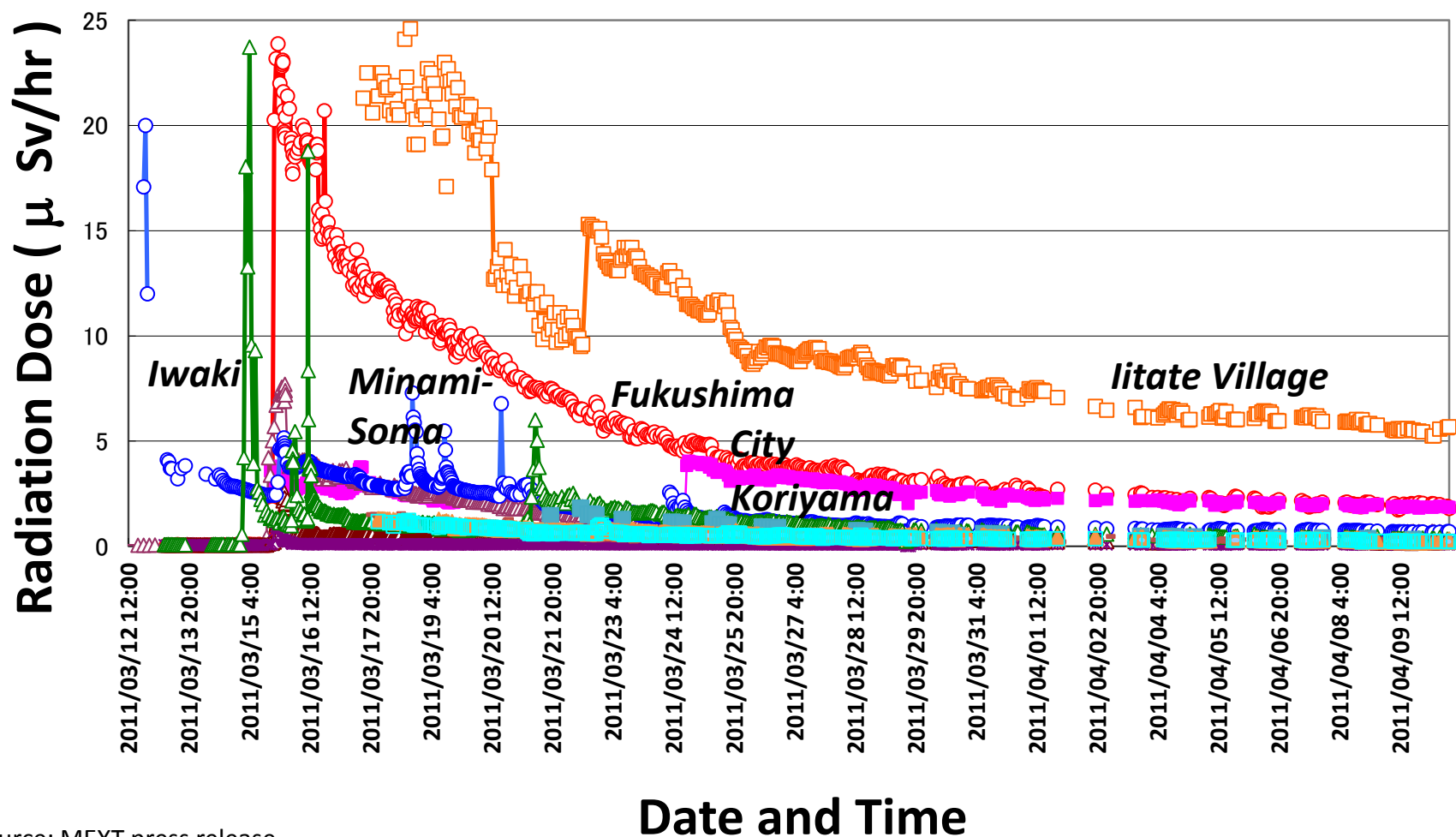

Source: MEXT press release

Cesium Deposition

April 29, 2011

Aerial Measuring Results

Joint US / Japan Survey Data

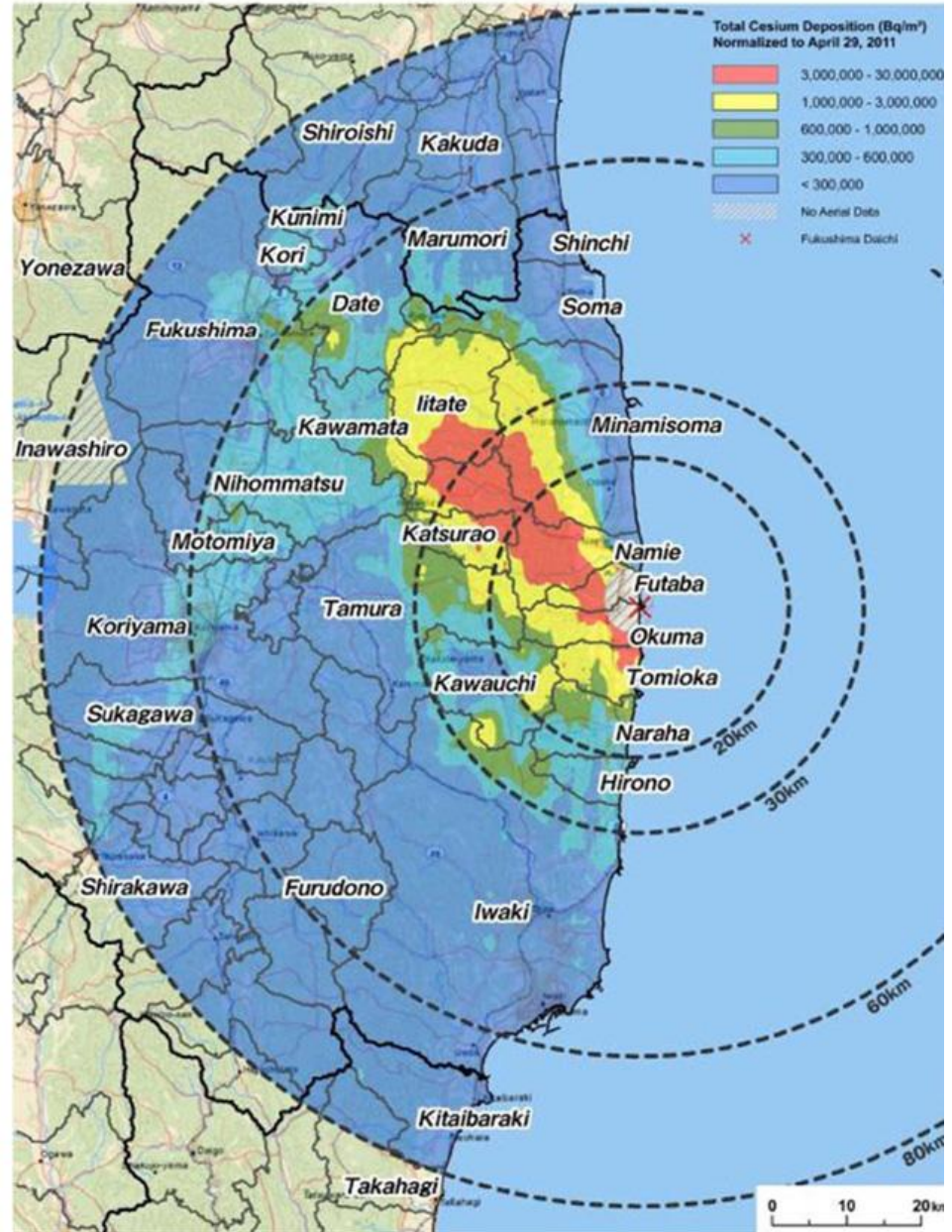

Monitoring of Radiation Dose Change in 2 Years

November 5, 2011

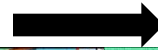

November 19, 2013

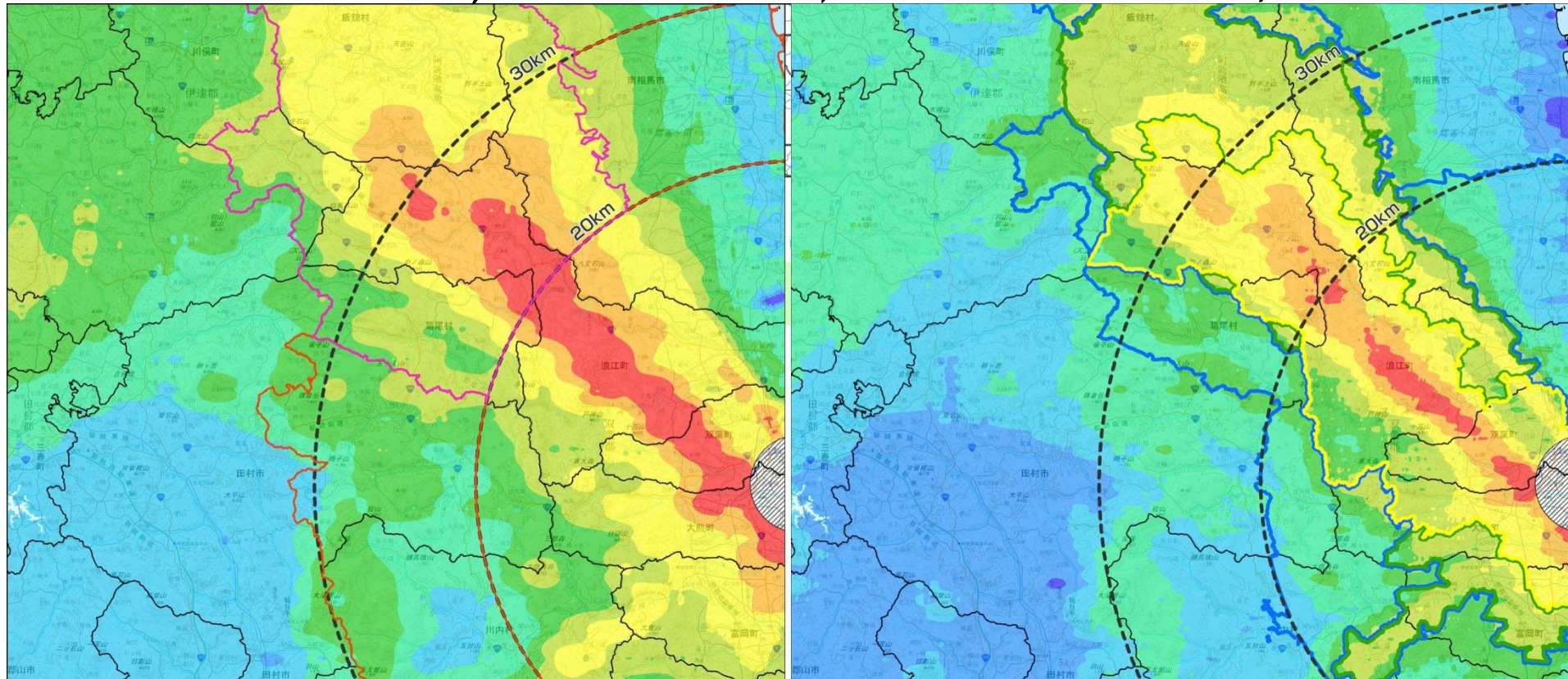

Decrease of Dose Rate through
(1)Radioactive decay
(2)Reduction by natural dispersion
(3)Decontamination action

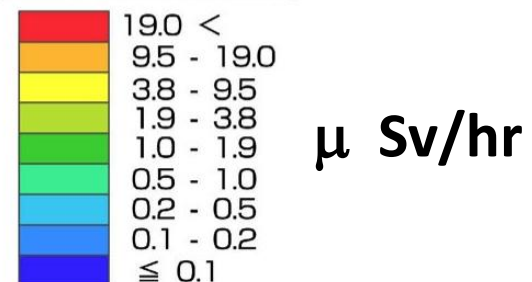

Evacuation of Residents

➤ The government took measures such as taking shelters or evacuation as follows based on the reports from Fukushima Daiichi & Daini.

Fri, 11 March

14:46 The Earthquake

19:03 Emergency Declaration by the Gov't (Daiichi)

21:23 3 km radius evacuation (Daiichi)

10 km radius taking shelter (Daiichi)

Sat, 12 March

5:44 10 km radius evacuation (Daiichi)

7:45 3 km radius evacuation (Daini)

10 km radius taking shelter (Daini)

17:39 10 km radius evacuation (Daini)

18:25 20 km radius evacuation (Daiichi)

Tue, 15 March

11:00 20-30 km radius taking shelter (Daiichi)

Thu, 21 April

11:00 20 km radius is designated as “**Restricted Area**” (Daiichi)

Fri, 22 April

9:44 20-30 km radius taking shelter has been lifted (Daiichi)

Establishment of “**Planned Evacuation Area**” and “**Emergency Preparation Area**”

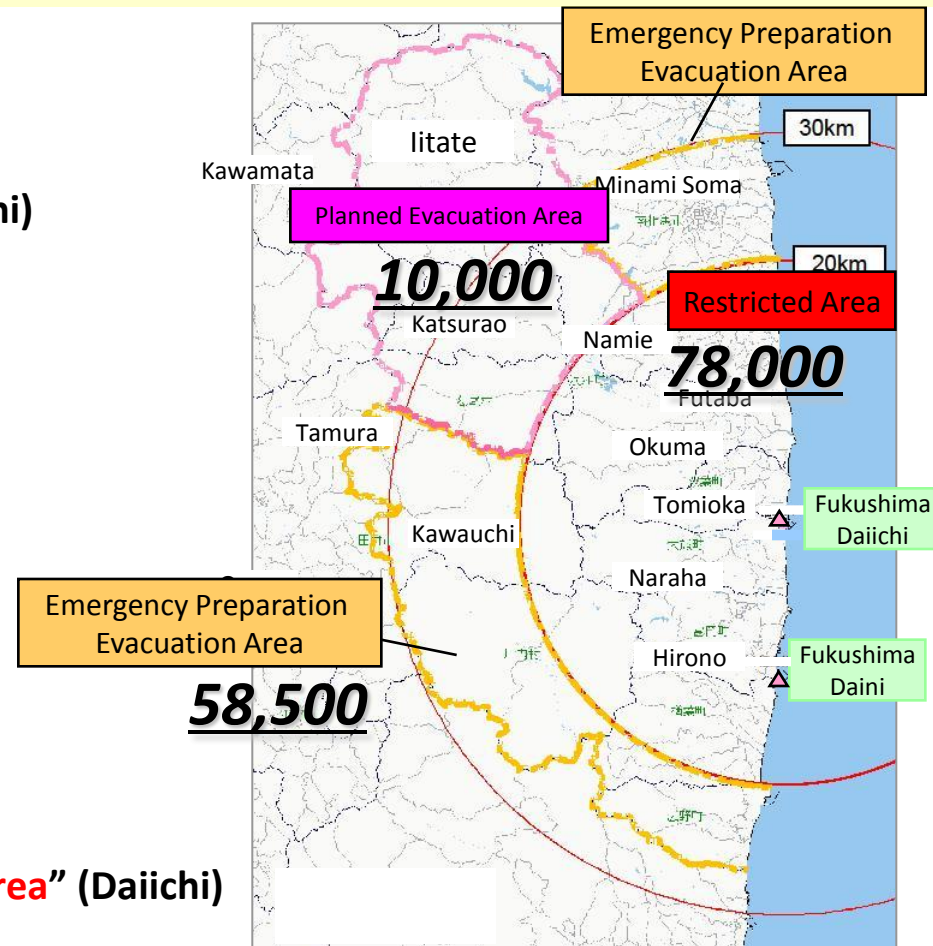

Source: NISA website

Direct Causes of the Fukushima Daiichi Accident

Final Report of the AESJ Investigation Committee

➤ **Inadequacies in Tsunami Measures**

- Critical incidents have not been utilized for developing effective prevention measures. ex. Jogan Off the Coast Sanriku Tsunami Earthquake

➤ **Inadequacies in Severe Accident Management Measures**

- No reinforcement of severe accident management measures after 2002.
- No severe accident management measures for external events as earthquakes and tsunamis.
- Japan did not adopt reinforcement of terrorist measures taken by many countries after 9.11.

➤ **Inadequacies in Emergency response Measures, Post-accident Management and Other Mitigation/Recovery Measures**

- The setting of a 10-kilometer radius emergency evacuation zone was not sufficient.
- Emergency offsite center was damaged by the earthquake and could not be used.
- Municipal/government directions on Iodine intake was not communicated sufficiently, resulting in the intake by only a few of the local population.

Underlying Causes of the Accident

Final Report of the AESJ Investigation Committee

- 1. Lack of awareness on the roles & responsibilities by experts**
- 2. Shortfalls in establishing safety measures & fostering safety awareness by utilities**
- 3. Lack of safety awareness by the regulatory body**
- 4. Inadequacies in attitude of learning from efforts and collaborations in the international community**
- 5. Shortage of qualified personnel dedicated to ensuring safety and inadequacies in organization & management framework**

Recommendations made by the Final Report of the AESJ Investigation Committee

50 Items in 5 Categories

- 1. Items Related to Direct Causes (5)**
- 2. Items Related to Organizational Factors of the Underlying Causes (14)**
- 3. Items Related to Nuclear Safety Fundamentals (14)**
- 4. Common Items (12)**
- 5. Items Related to Post-Accident Management (5)**

Summary of the Recommendations by AESJ

- **Recommendations have been made over broad areas based on the results of root cause analysis.**
- **A broad range of issues need to be addressed for ensuring nuclear safety:**
 - **fundamental concept on nuclear safety must be clearly shown;**
 - **PRA appropriately applied;**
 - **safety goal defined clearly;**
 - **defense-in-depth accurately understood and applied to plant design, accident management, disaster management, etc.**
- **The importance on the role of nuclear safety research for resolving these issues and its continuous development is emphasized. Research activities will lead to expand knowledge-base; to get deeper insight on the broader issues and to generate better and optimized solutions out of possible options.**

Epilogue

- **The recommendations have been made to prompt government organizations, the industries, the academia and research institutions to take concrete actions for promoting nuclear safety.**
- **Some of the recommendations involve goals to be pursued by the AESJ. Concurrently with making efforts on necessary improvements, the AESJ aims to interact with related organizations for the realization of the recommendations.**
- **These recommendations have been proposed, in view of the significance of transparency of nuclear-related information, to be shared by all parties with interest in nuclear power. It is critically important for all organizations and experts to take to heart the items recommended and to endeavor earnestly for the achievement of nuclear safety. Organizations and experts in nuclear power field are not qualified to be involved in facilities and activities unless these goals are realized.**

English version of the AESJ Final Report will be available very soon.

Editor :
Atomic Energy Society of Japan



The Fukushima Daiichi Nuclear Accident

Final Report of AESJ Investigation Committee

This report was completed by the AESJ, Japanese academia in nuclear science/engineering, with concerted effort by specialists.

It covers all aspects of technical issues of the Accident.

New
Book

Thank you very much for your attention



Additional Slides

New Safety Standards in Japan

< New Safety Standards >

< Previous Safety Standards >

Design Basis Standard
to prevent Severe Core Damage
(Only assuming single failure etc.)

Consideration for Natural Events
Consideration for Fire
Consideration for Reliability
Reliability of power source
Performance of cooling equipment
Performance of other equipment
Tolerability for Earthquake & Tsunami

Preventing Large Scale Release
Intentional Airplane Crash
Preventing CV Failure
Preventing Severe Core Damage (Assuming multiple malfunction)
Consideration for Natural Events
Consideration for Fire
Consideration for Reliability
Reliability of power source
Performance of cooling equipment
Performance of other equipment
Tolerability for Earthquake & Tsunami

New
(Countermeasures
against
Severe Accident)

Enhancement

Enhancement

Enhancement of Design Basis Standard

Review Design Basis Standard completely,

“Design Basis Standard with No Severe Core Damage assumed”

- ① Tornadoes and Bushfires included as Natural Events to be considered**
- ② Enhancement of Fire Protection**
- ③ Enhance Reliability of Components particularly important to the safety
(Redundancy of Components with Long Time Demand)**
- ④ Enhancing external electricity supplies
(Multiple Power Line Systems from Separate Substations)**
- ⑤ Physical Protection of Heat Removal System
(Protection of Seawater Pumps)**

Countermeasures against SA (Severe Core Damage)

Requirements for Countermeasures against Severe Core Damage assuming beyond the Design Basis Accidents.

- ① Countermeasures for Failure of Reactor Shutdown**
- ② Countermeasures for Loss of Cooling Reactor (at high pressure)**
- ③ Countermeasures for Loss of Depressurization**
- ④ Countermeasures for Loss of Cooling Reactor (at low pressure)**
- ⑤ Countermeasures for Loss of Ultimate Heat Sink (LUHS)**
- ⑥ Securing Support Function (Make-up Water, Electricity Sources)**

Countermeasures against SA (Containment Vessel Failure)

Requirements for Countermeasures against Containment Vessel Failure assuming Severe Core Damage.

- ① Countermeasures for Cooling, Depressurization and Radioactive Material Mitigation (CV Spray)**
- ② Countermeasures for Cooling and Depressurization of CV (Filtered Venting system)**
- ③ Countermeasures for Cooling Melted Core fallen to the Bottom of CV**
- ④ Countermeasures against Hydrogen Explosions inside CV**
- ⑤ Countermeasures against Hydrogen Explosions at the Reactor Building, etc.**
- ⑥ Countermeasures for Cooling of Spent Fuel Storage Pools**

Countermeasures against Extreme External Hazards

- **Flexible measures mainly by mobile facilities**
 - Against loss of large area of plant by various accidents, hazards, and attacks
 - To maintain/restore cooling function in PCV, CV, and SFP
 - Facilities stored safely against extreme external hazards
 - Electricity and water inlets available under loss of large area of plant
- **Hardened fixed facilities**
 - Against postulated external events beyond design basis with relatively high frequency
 - To improve reliability of countermeasures
 - To prevent large release of radioactive substances
 - Hardened facilities, e.g. water injection to CV spray and pedestal, filtered vent

Regulatory Requirements for Power Supply

- Fuel for emergency diesel generators should be stored in the for 7 days of continuous operation (to prepare possible loss of external power supply)
- Independent power supply as severe accident measure (in case of possible station black out)
- No core damage before the connection to independent power supply (as plant design criteria)
- DC power supply capability for 24 hours (as severe accident management criteria)
- Additional sets of DC power supply before 2020

30 Measures that Should Be Addressed to Regulation Identified in NISA Report in February 2012

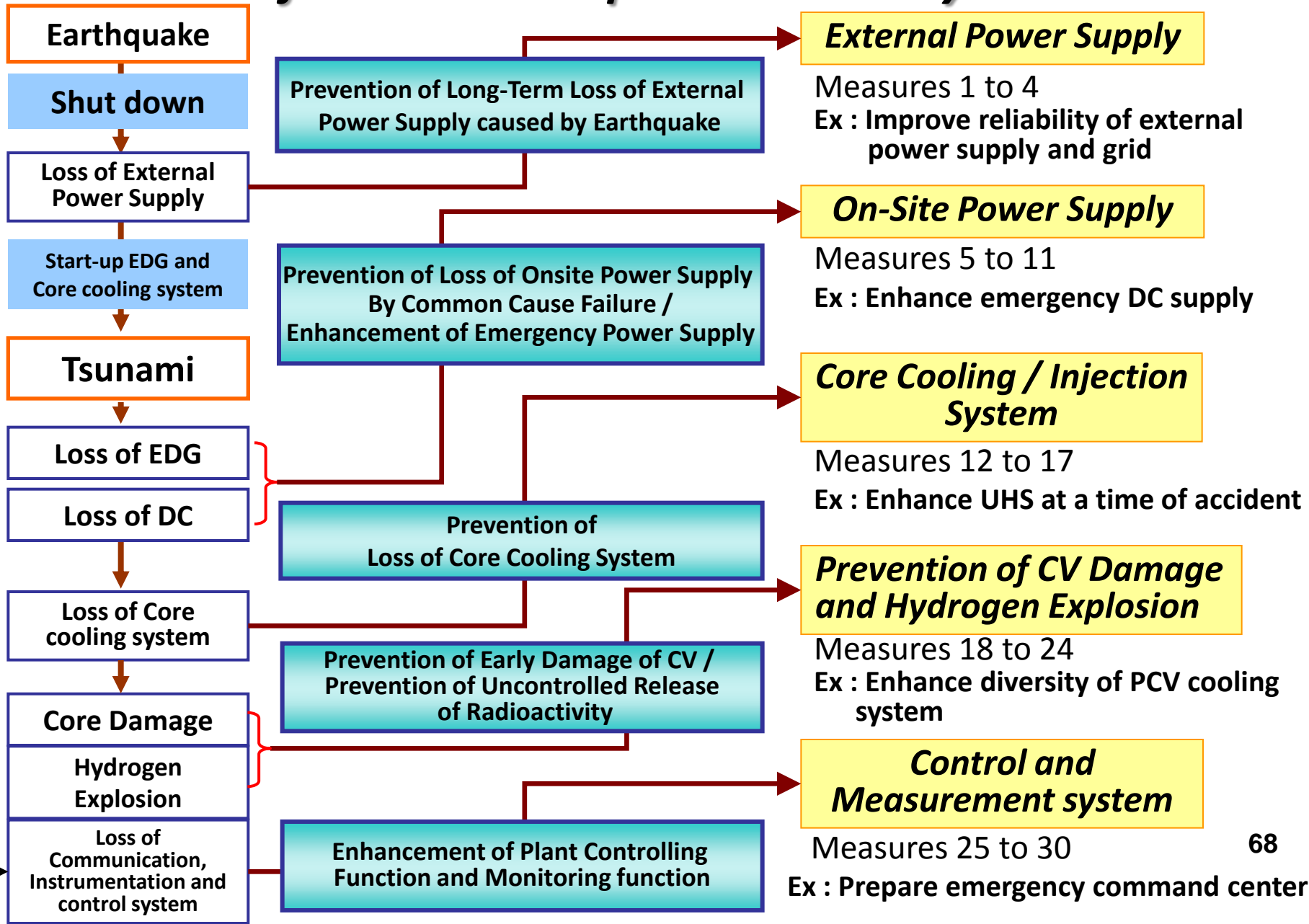

Basic Policies for the New Regulatory Requirements

- Establish requirements to prevent loss of safety functions due to common causes and progression of severe accidents

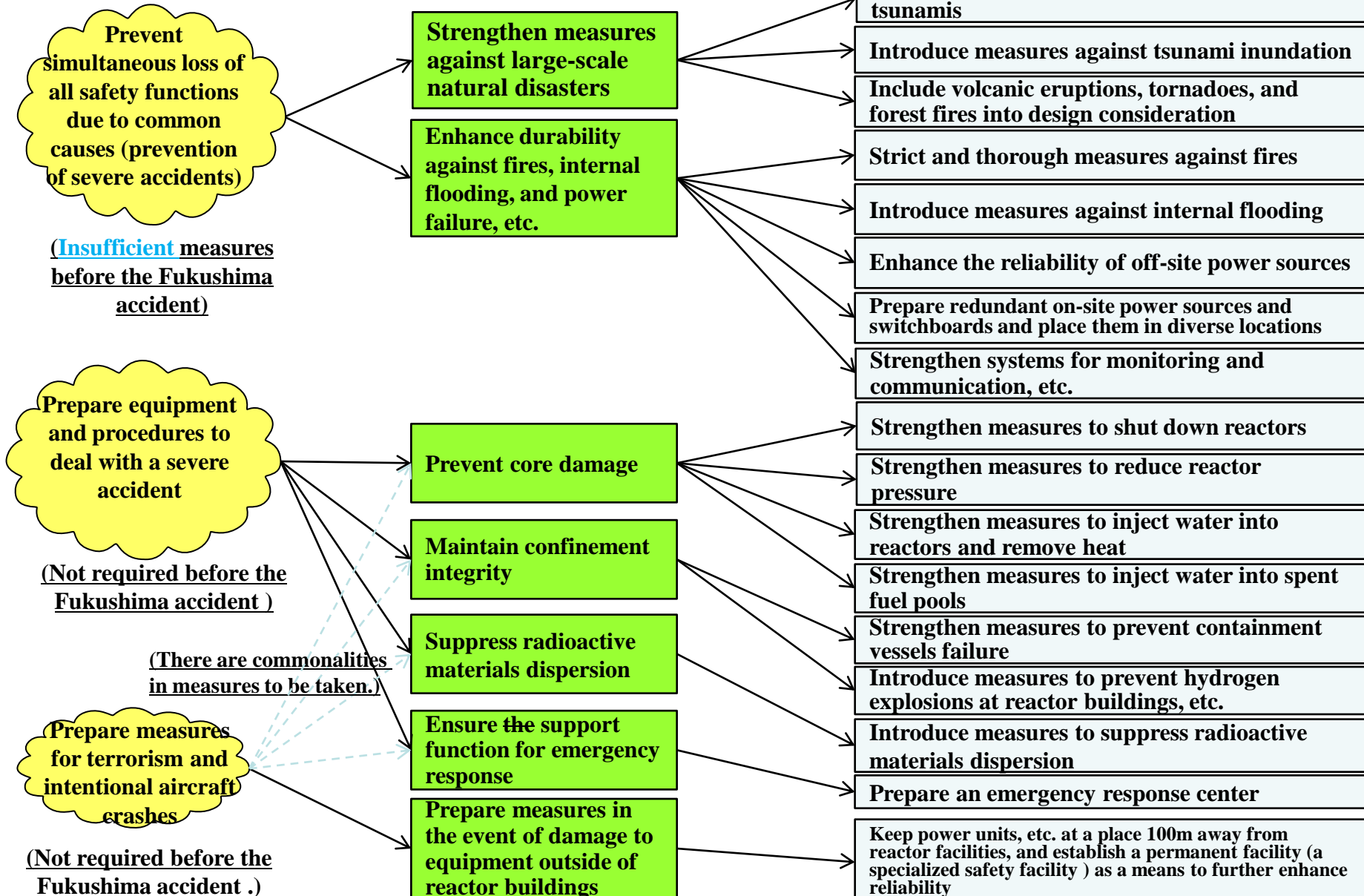

Flow chart for Defense-in-Depth

(IAEA INSAG definition)

- Success is defined for each level of defense -in-depth.
- If the provisions of a given level of defense fail to control the evolution of a sequence, the subsequent level will come into play.

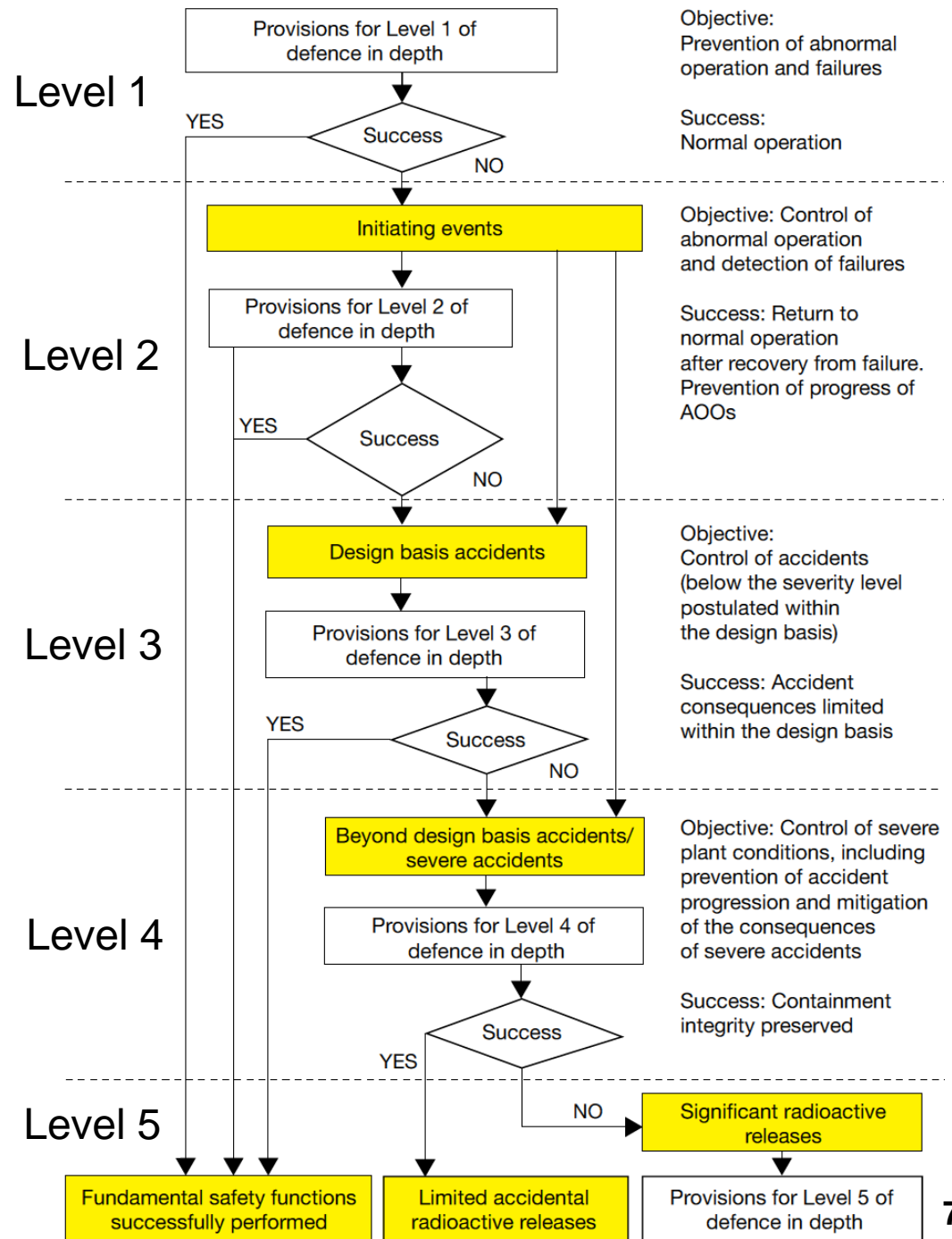

Summary of Insights from Beyond Design Basis Considerations

Inadequate Consideration of Beyond Design Basis Accidents (BDDBA)

**Inadequate Assurance of Core
Cooling Capability for BDDBA
Scenarios in the Design**

**Inadequate Consideration of
BDDBA in Accident
Management**

**Failure to
ensure core
cooling in
BDDBA
conditions**

**Failure of
plant
indication in
MCRs and
ERCs**

**BDDBA
documented
guidance
inadequate**

**Insufficient
classroom
training,
drills and
exercises**

MCR : Main Control Room

ERC : Emergency Response Center

Visit to Fukushima Daiichi Site on April 9, 2012

Unit 4



Low Pressure Coolant Injection

- Introduce water to cool the reactor core and maintain water levels

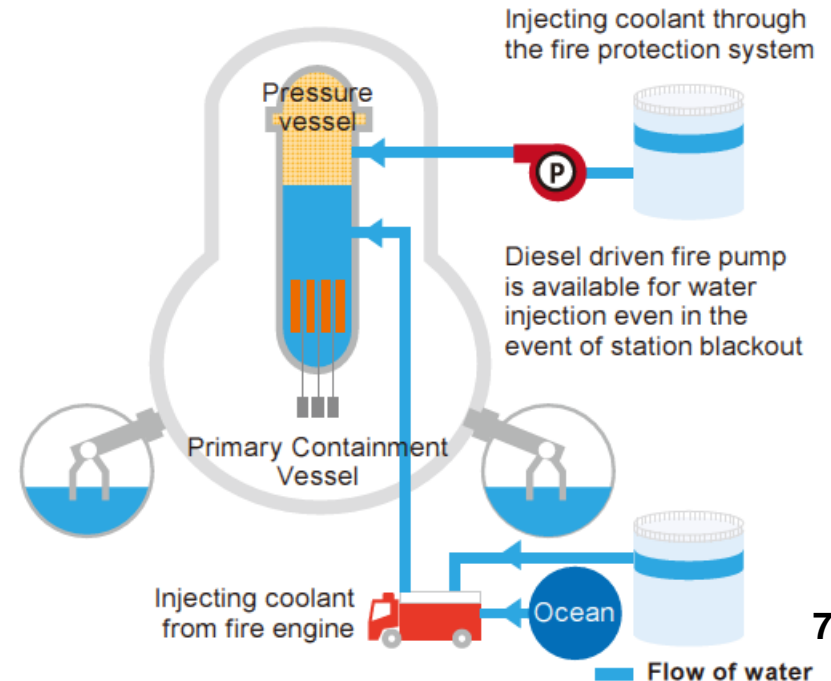
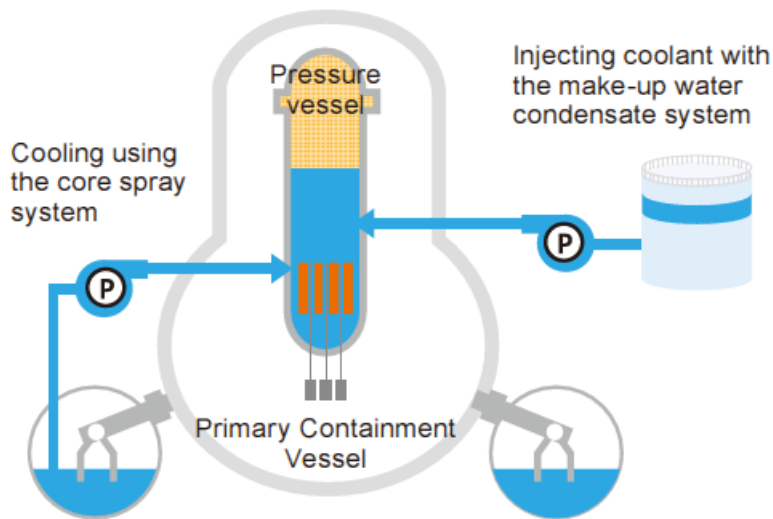
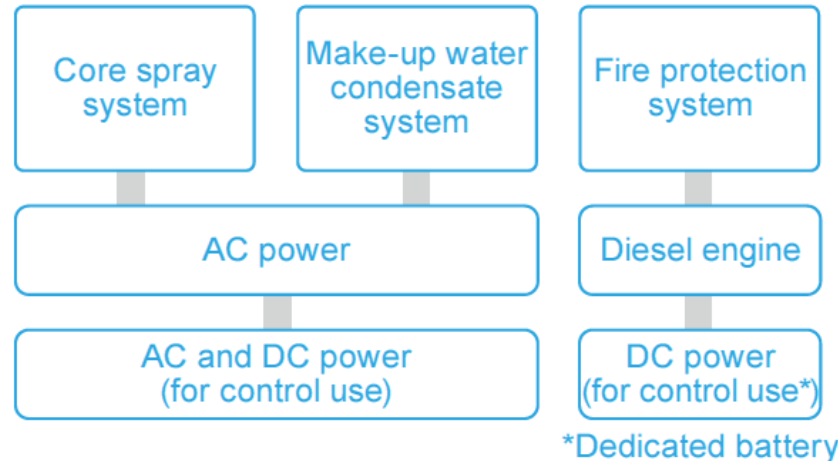

Heat Removal

- Transfer the heat coming from the reactor core to water to release it outside

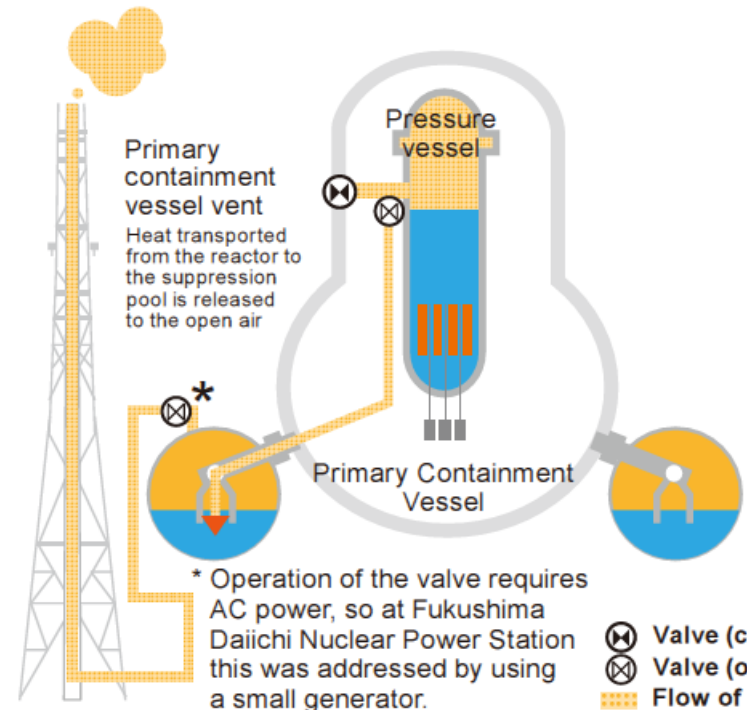
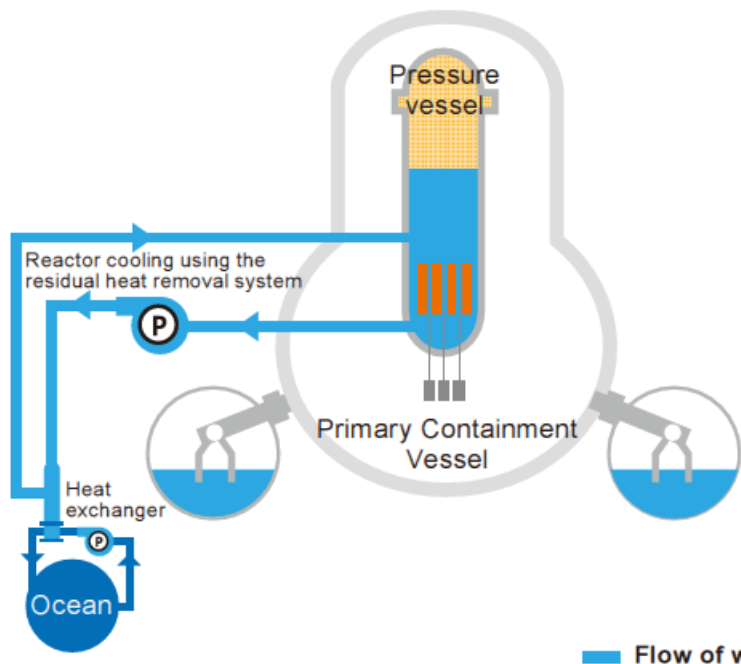
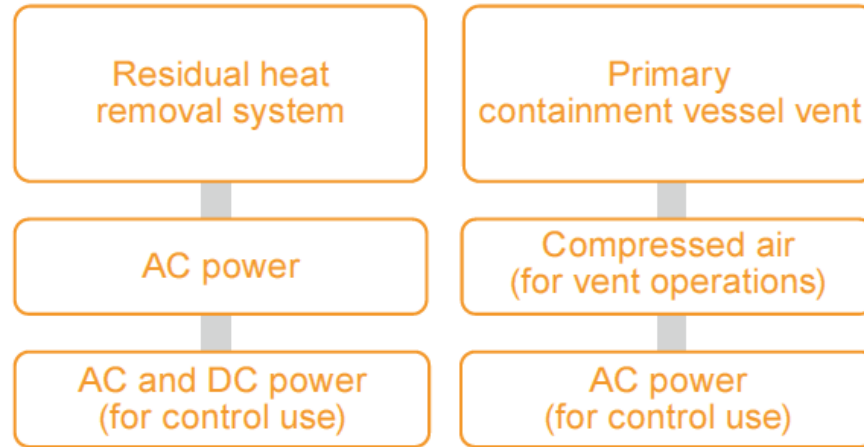

Primary Containment Vessel Venting Operation

No power source for the MO-valve
 No power source to the solenoid valve
 Low pressure to actuate the AO-valve
 High radiation level in R/B

- ➔ Manual operation
- ➔ Engine driven generator
- ➔ Engine driven air compressor

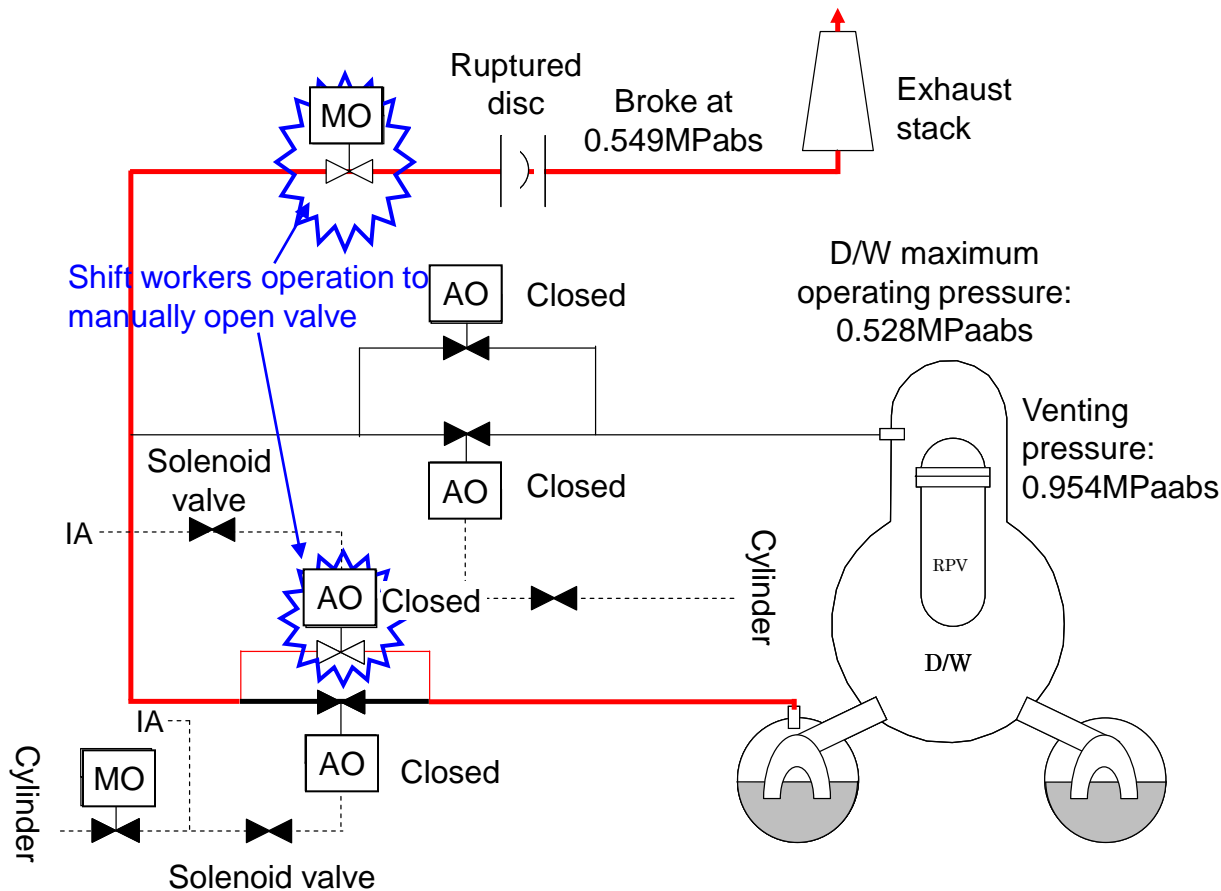

Self-contained breathing apparatus

On-site Radiation Monitoring in Fukushima Daiichi Site From March 11 to 18, 2011

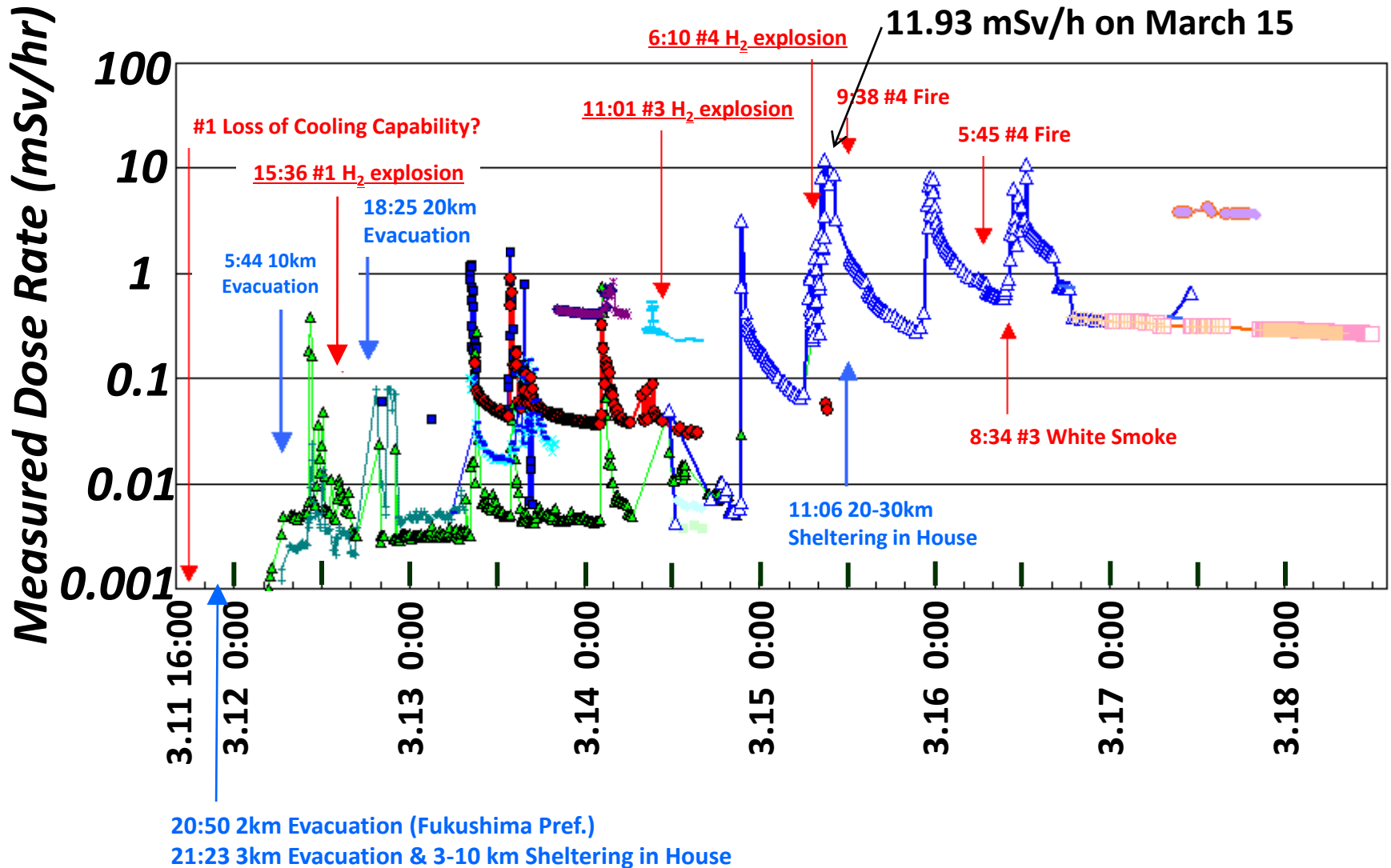

Fuel Assemblies in Reactor Core and Spent Fuel Pool

<i>Unit</i>	<i>1</i>	<i>2</i>	<i>3</i>	<i>4</i>	<i>5</i>	<i>6</i>
<i>Number of Fuel Assembly in the Core</i>	400	548	548*	-	548	764
<i>Number of <u>Spent</u> Fuel Assembly in the SFP</i>	292	587	514	1,331	946	876
<i>Number of <u>New</u> Fuel Assembly in the SFP</i>	100	28	52	204	48	64
<i>Water Volume (m³)</i>	1,020	1,425	1,425	1,425	1,425	1,497
<i>Heat Generation in Spent Fuel Pool (MW)</i>	0.18	0.62	0.54	2.26	0.08	0.07

** including 32 MOX Fuel Assembly*

Hydrogen Explosion in Unit 4 on March 15

Possible mechanisms ; (1) Zr-H₂O reaction in the SFP, (2) H₂ from Unit 3,
(3) Decomposition of H₂O into H₂ and O₂ under radiation

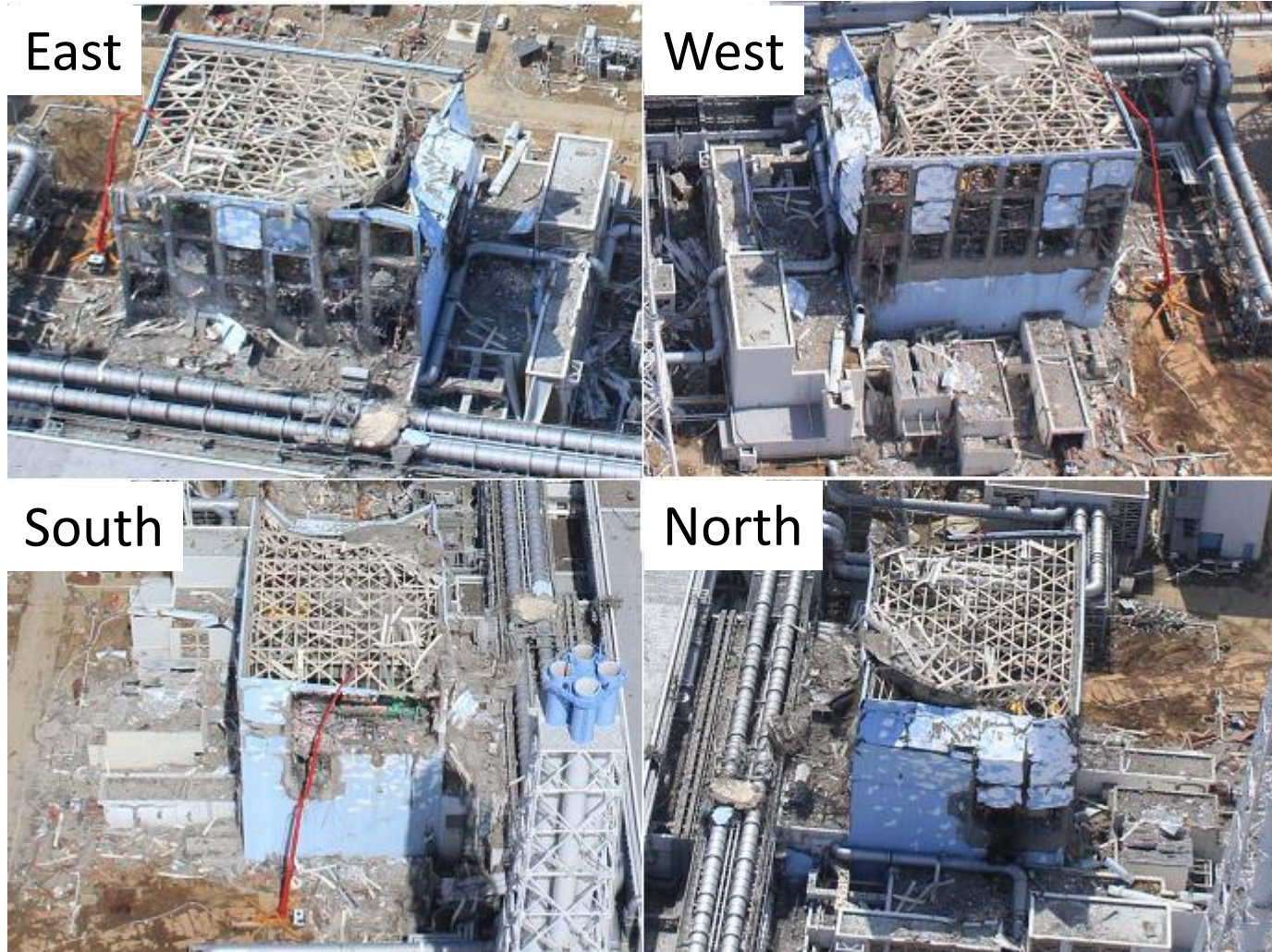

Unit 4 : Spent Fuel Pool

- ◆ *No significant damage was identified by underwater camera inspection*
- ◆ *Water sampling also shows relatively low radioactivity in SFP water*

*Analysis result of water in the SFP of Unit 4
(Date of Collection April 12 and 28)*

<i>Detected Nuclides</i>	<i>Density (Bq/cm³) on April 12</i>	<i>Density (Bq/cm³) on April 28</i>
<i>Cesium 134</i>	<i>88</i>	<i>-</i>
<i>Cesium 137</i>	<i>93</i>	<i>55</i>
<i>Iodine 131</i>	<i>220</i>	<i>27</i>

Source: TEPCO



Source: TEPCO

~~(A)~~ **Zr-H₂O reaction in the SFP at high temperature**

Experiments on High Concentration of Hydrogen Gas under Radiation at Boiling Temperature

G-values	-H ₂ O	e ⁻ _{aq}	OH	H	H ₂ O ₂	H ₂	HO ₂
Gamma-ray	4.1	2.7	2.8	0.56	0.68	0.45	~0.01
Alpha-ray	2.65	0.06	0.24	0.21	0.985	1.3	0.22

May 16, 2011

Prof. Katsumura Group

The University of Tokyo and JAEA

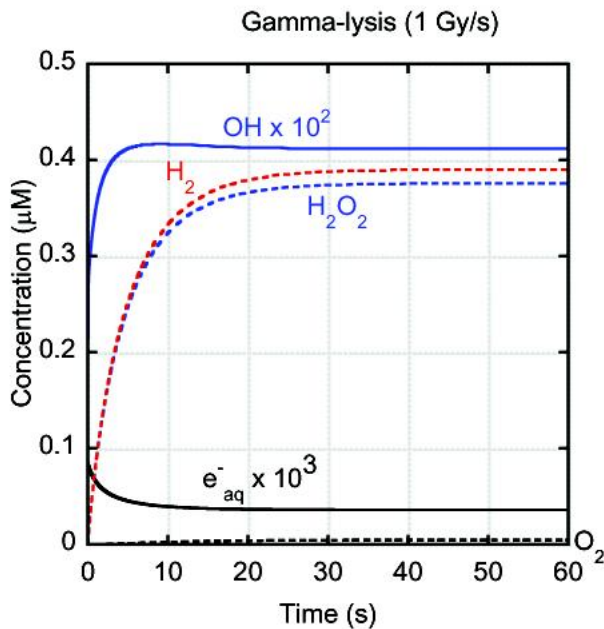

Typical BWR condition simulation of radiation chemistry reactions considering the reaction between H₂ and OH, resulting in steady state concentration of H₂.

New Finding by H₂ production under irradiation;

- Effective transfer of H₂ into gas phase at 100 C
- High concentration of H₂ through condensation of H₂O at lower temperature region

6.8 kGy/h for 1 hr
at 80, 97 and 100 C

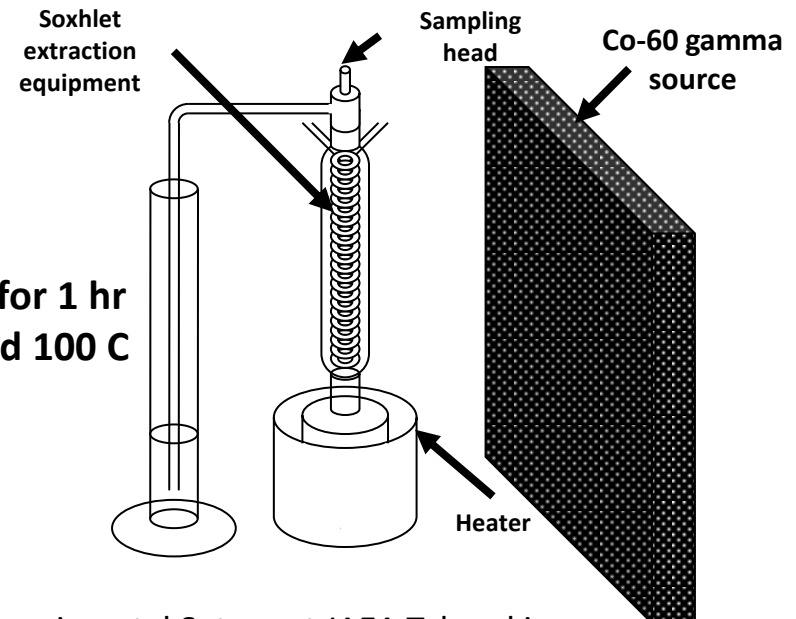

Experimental Set-up at JAEA Takasaki

Stand-by Gas Treatment Systems for Units 3 and 4

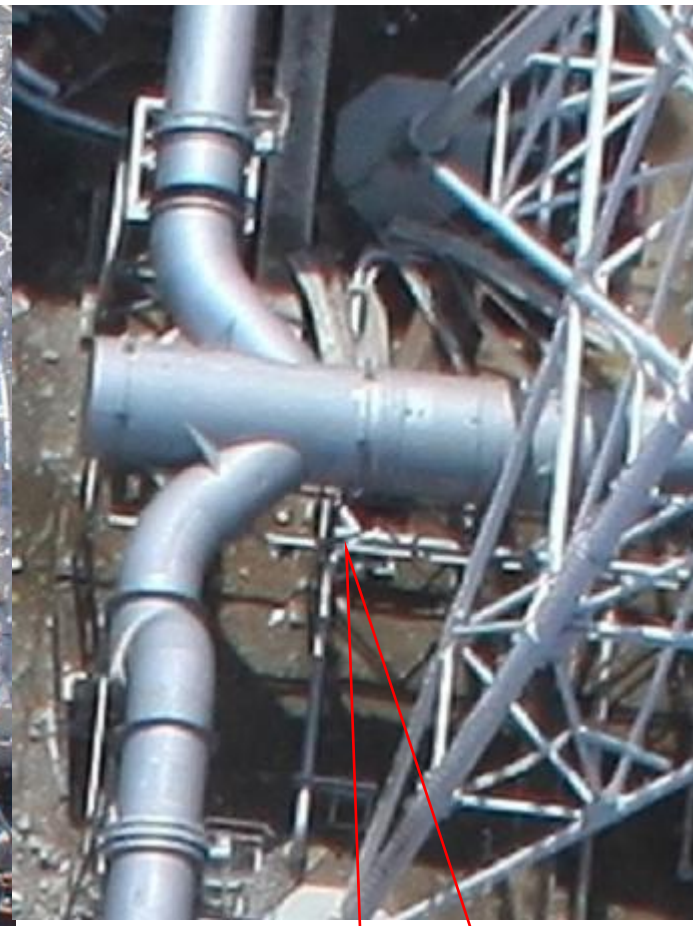

Pipes of stand-by gas treatment systems for Units 3 and 4 are connected.

Source: TEPCO

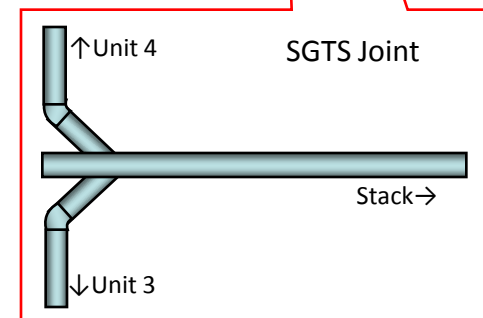

Possible Mechanism of Hydrogen Explosion in Unit 4

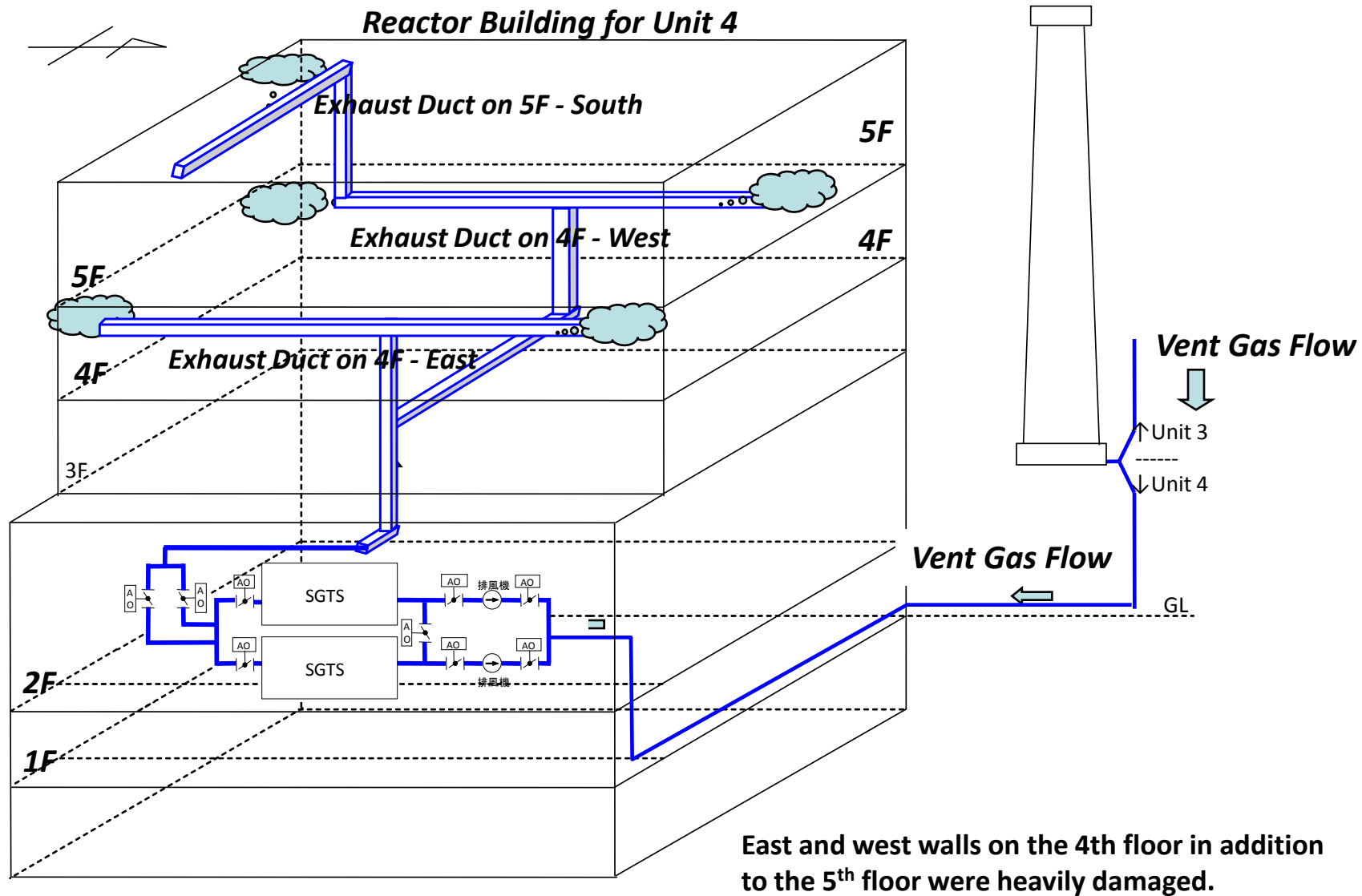

30 Measures that Should Be Addressed to Regulation Identified in NISA Report in February 2012

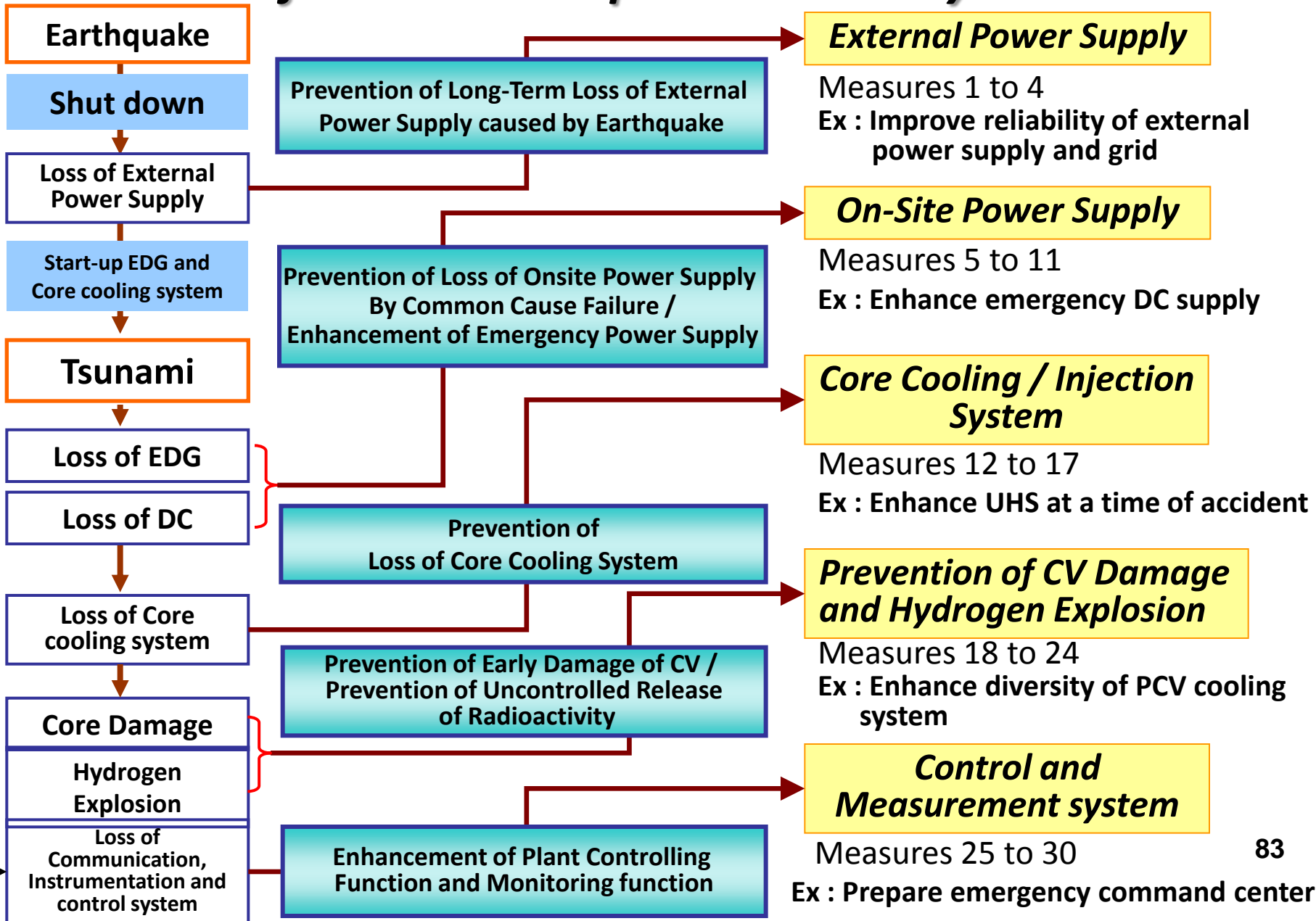

Lessons Learned Identified in Report to IAEA Ministerial Conference in June 2011

<i>Enhancement of Preventive Measures against Severe Accidents</i>	<ul style="list-style-type: none"> (1) Strengthening of measures against earthquake and tsunami (2) Ensuring power supplies (3) Ensuring robust cooling functions of reactors and PCVs (4) Ensuring robust cooling functions of spent fuel pools (5) Thorough accident management (AM) measures (6) Resolution of issues concerning multi unit site (7) Consideration of NPS layout in basic designs (8) Ensuring water tightness of essential equipment / facilities 	<p>Source: Report of Japanese Government to the IAEA Ministerial Conference on Nuclear Safety</p> <p>http://www.kantei.go.jp/foreign/kan/topics/201106/iae_a_houkokusho_e.html</p>
<i>Enhancement of Mitigation Measures of Severe Accidents</i>	<ul style="list-style-type: none"> (9) Enhancement of measures to prevent hydrogen explosion (10) Enhancement of containment venting system (11) Improvement of environment / habitability for emergency response (12) Enhancement of radiation protection management system in case of accident (13) Enhancement of training responding to severe accidents (14) Enhancement of instrumentation for reactors, PCVs, etc. (15) Implementation of centralized control of equipment for emergency and rescue team 	
<i>Enhancement of Nuclear Emergency Responses</i>	<ul style="list-style-type: none"> (16) Response to combined emergencies of natural disasters and prolonged nuclear accident (17) Enhancement of environmental monitoring (18) Clarification of roles and responsibilities of central and local organizations (19) Enhancement of communication in case of accident (20) Enhancement of response to assistance from overseas and information supply to international community (21) Adequate understanding and prediction of consequences of radioactive releases (22) Clarification of standards for evacuation in wide areas and radiation protection in case of emergency 	
<i>Reinforcement of Safety Infrastructure</i>	<ul style="list-style-type: none"> (23) Enhancement of framework for safety regulation (24) Enhancement / implementation of legal framework and regulatory guides and standards (25) Human resources for nuclear safety and nuclear emergency preparedness and response (26) Ensuring independence and diversity of safety systems (27) Effective use of probabilistic safety assessment (PSA) in risk management 	
<i>Safety Culture</i>	<ul style="list-style-type: none"> (28) Strong initiative to foster safety culture 	

Evacuation of Residents

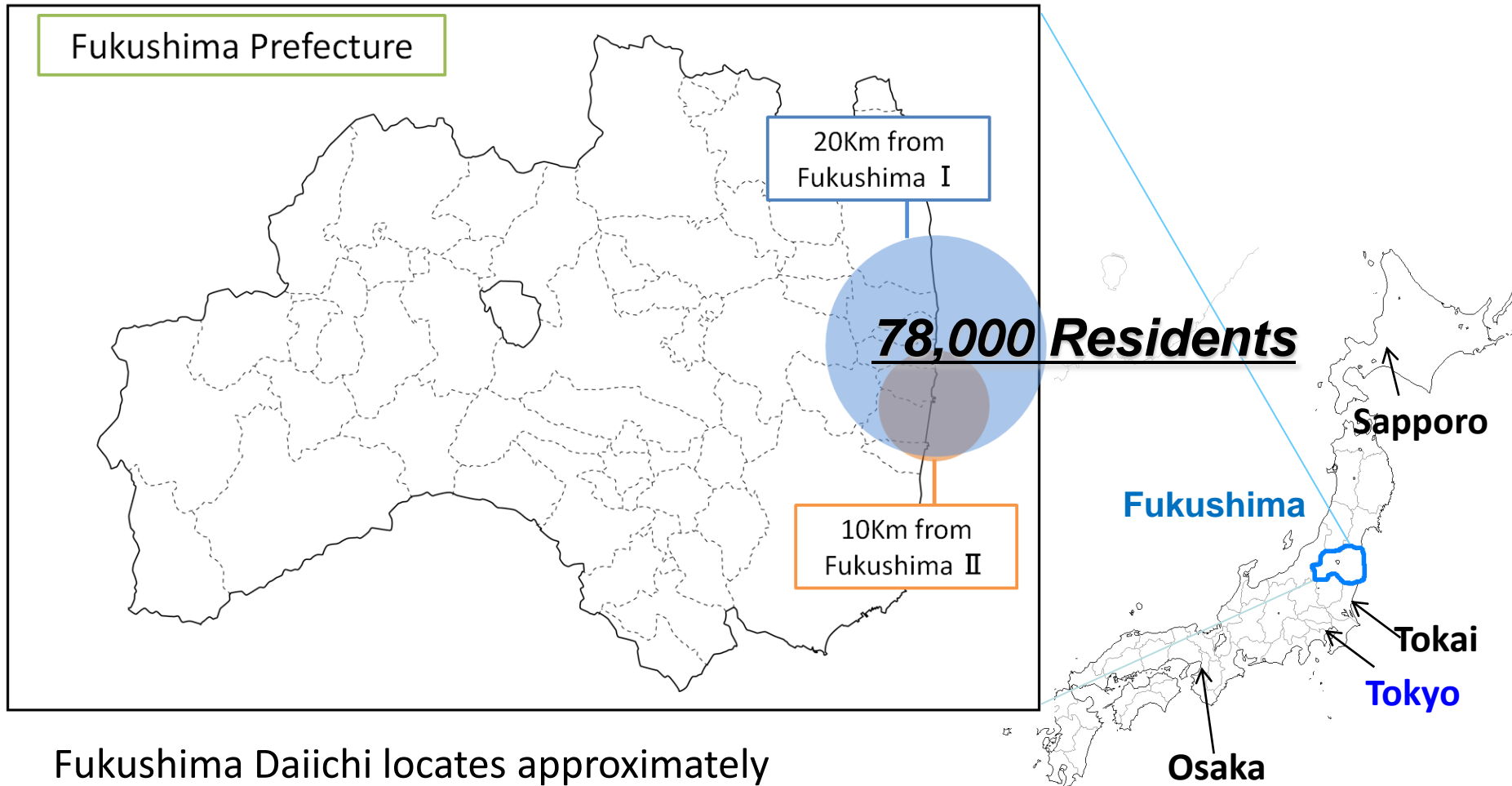

Fukushima Daiichi locates approximately

- 110 km from Tokai
- 230 km from Tokyo
- 580 km from Osaka
- 600 km from Sapporo

August 28, 2011

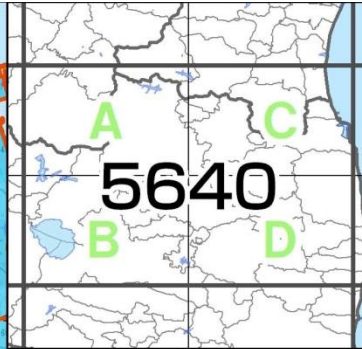
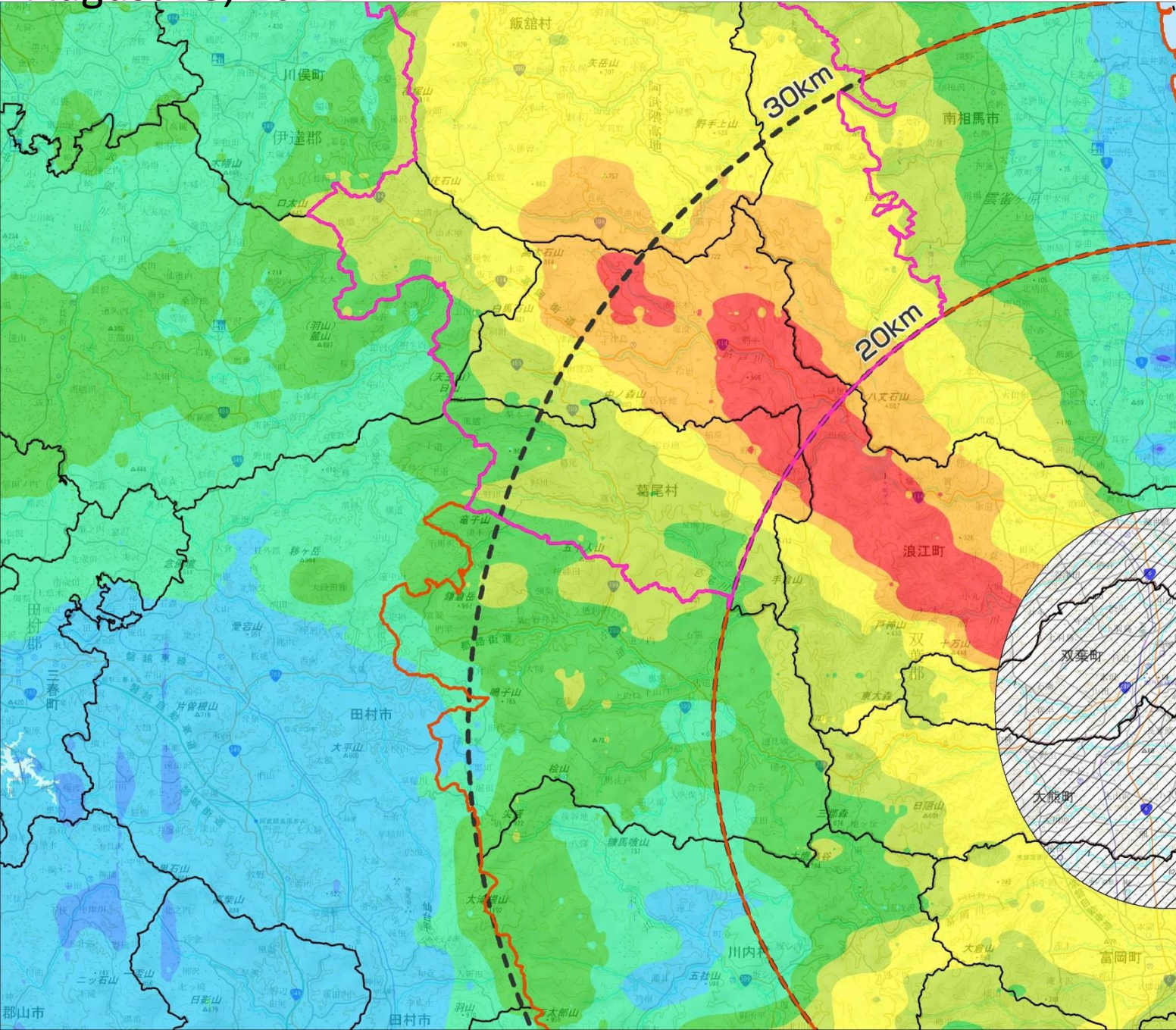

5640 - D

文部科学省 MINISTRY OF EDUCATION, CULTURE, SPORTS, SCIENCE AND TECHNOLOGY JAPAN

放射線量等分布マップ
- 航空機モニタリング -

凡例

地表面から1mの高さの
空間線量率($\mu\text{Sv} / \text{hr}$)
[8月28日現在の値に換算]

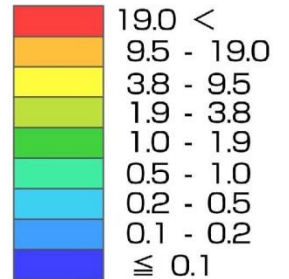

測定結果が得られていない範囲

— 計画的避難区域
— 緊急時避難準備区域

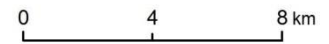

背景地図：電子国土

September 18, 2011

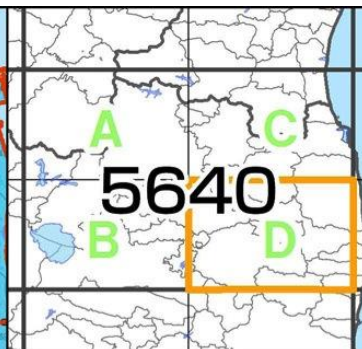
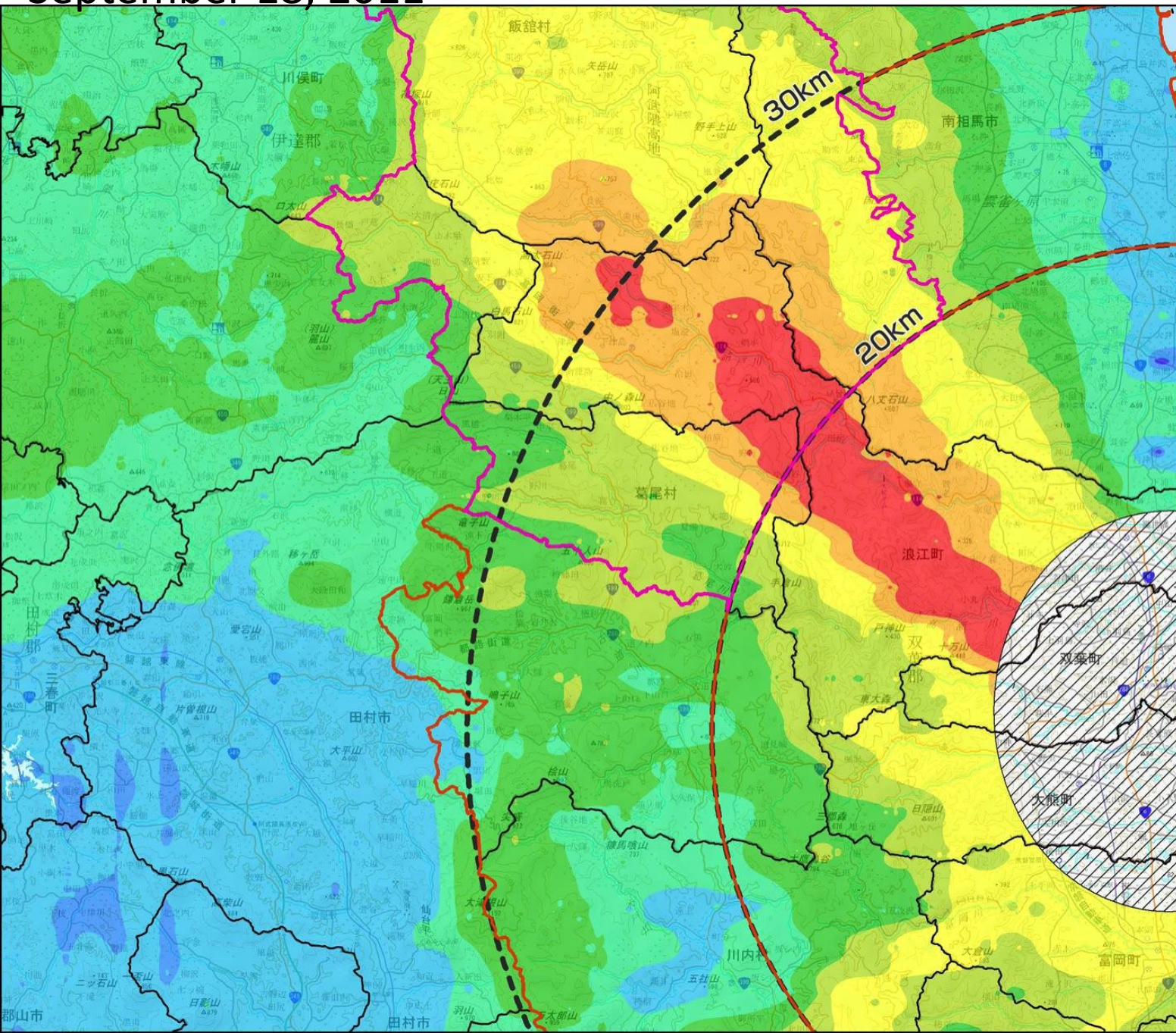

5640 - D

文部科学省 MINISTRY OF EDUCATION, CULTURE, SPORTS, SCIENCE AND TECHNOLOGY JAPAN

放射線量等分布マップ
- 航空機モニタリング -

凡例

地表面から1mの高さの
空間線量率($\mu\text{Sv} / \text{hr}$)
[9月18日現在の値に換算]

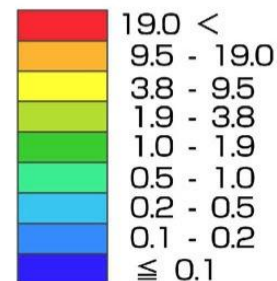

測定結果が
得られていない範囲

- 計画的避難区域
- 緊急時避難準備区域
(平成23年9月30日解除)

0 4 8 km

背景地図：電子国土

October 13, 2011

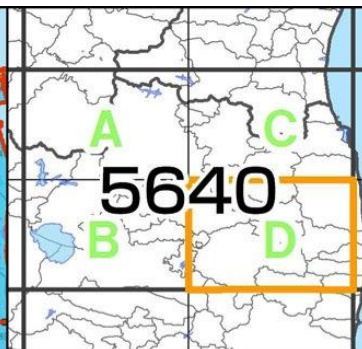
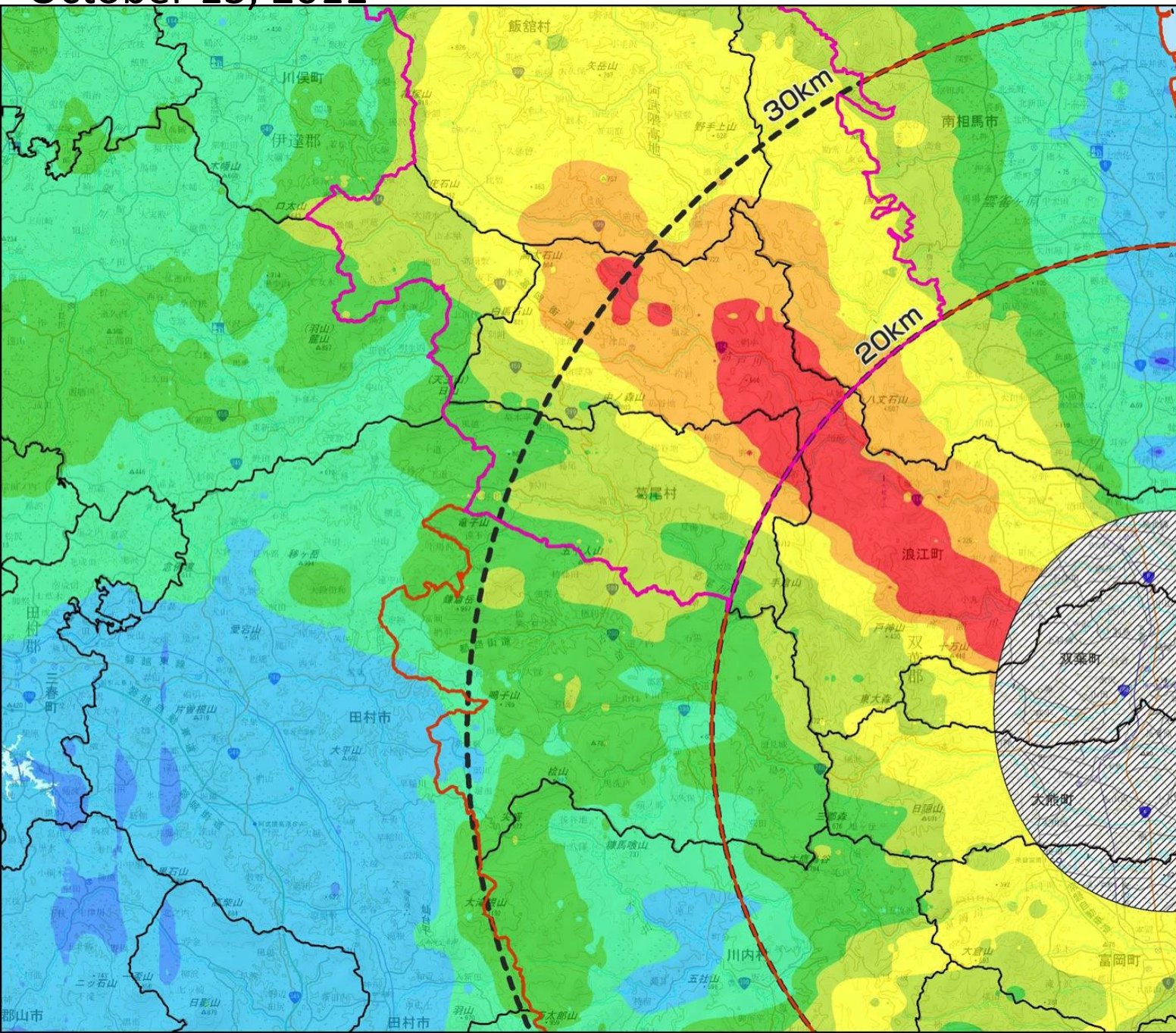

5640 - D

文部科学省 MINISTRY OF EDUCATION, CULTURE, SPORTS, SCIENCE AND TECHNOLOGY JAPAN

放射線量等分布マップ
- 航空機モニタリング -

凡例

地表面から1mの高さの
空間線量率($\mu\text{Sv} / \text{hr}$)
[10月13日現在の値に換算]

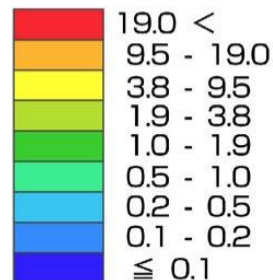

測定結果が
得られていない範囲

計画的避難区域
緊急時避難準備区域
(平成23年9月30日解除)

0 4 8 km

背景地図：電子国土

November 1, 2011

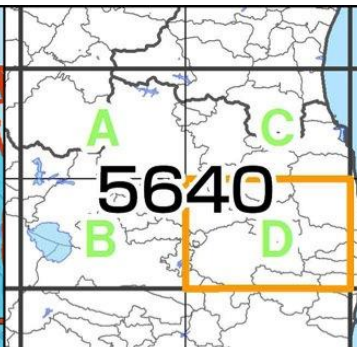
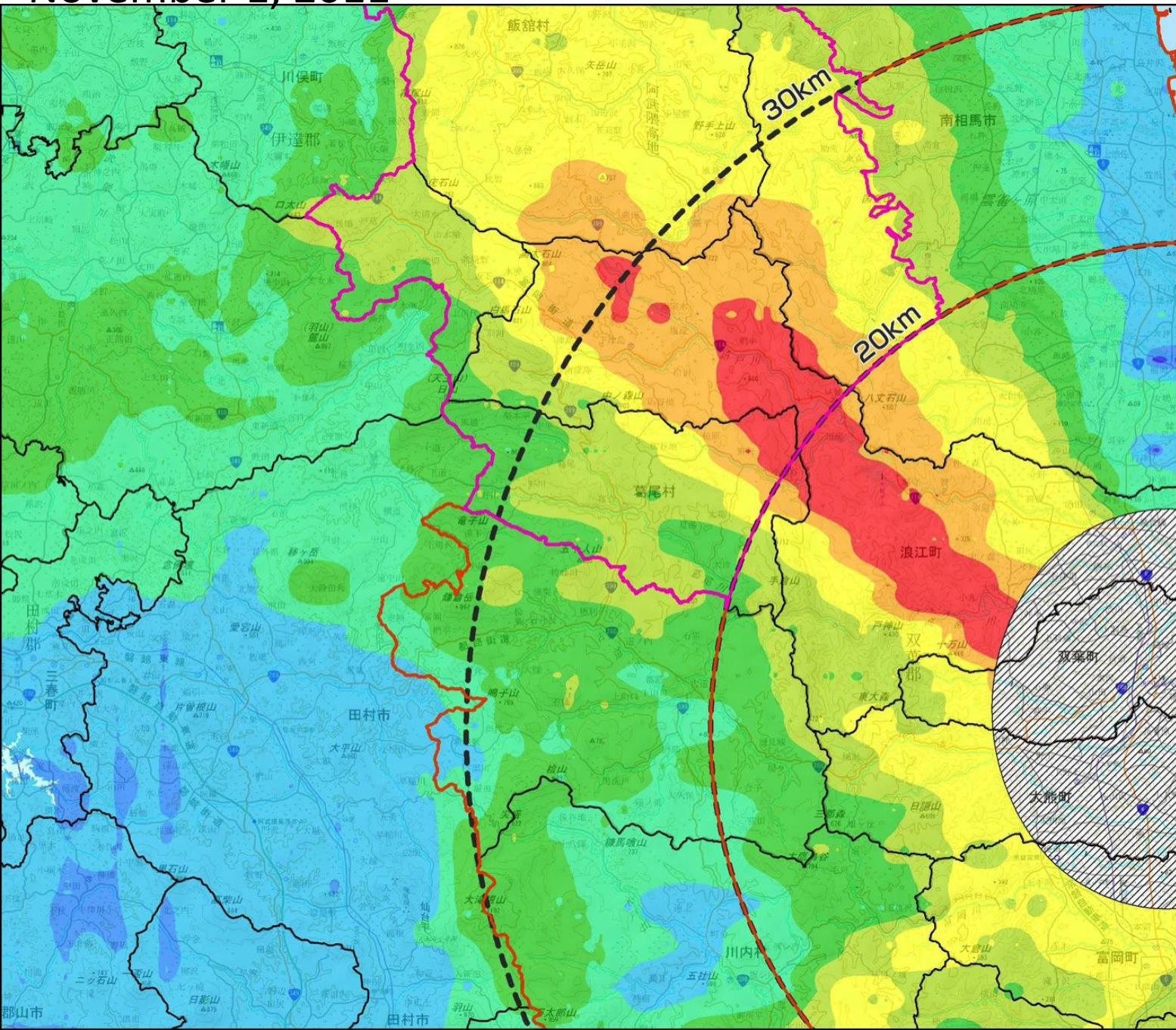

5640 - D

文部科学省 MINISTRY OF EDUCATION, CULTURE, SPORTS, SCIENCE AND TECHNOLOGY JAPAN

放射線量等分布マップ - 航空機モニタリング -

凡例

地表面から1mの高さの空間線量率 ($\mu\text{Sv/h}$)
[11月1日現在の値に換算]

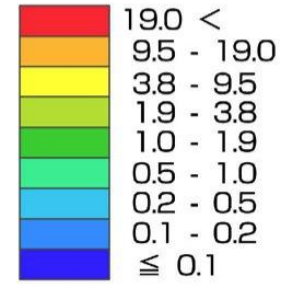

測定結果が得られていない範囲

※本マップには天然核種による空間線量率が含まれています。

計画的避難区域
 緊急時避難準備区域 (平成23年9月30日解除)

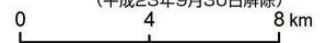

背景地図：電子国土

November 5, 2011

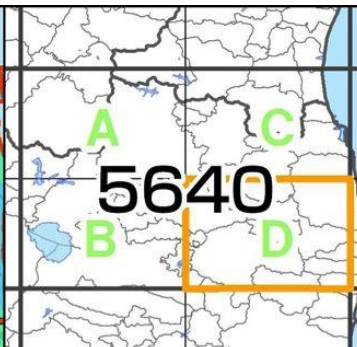
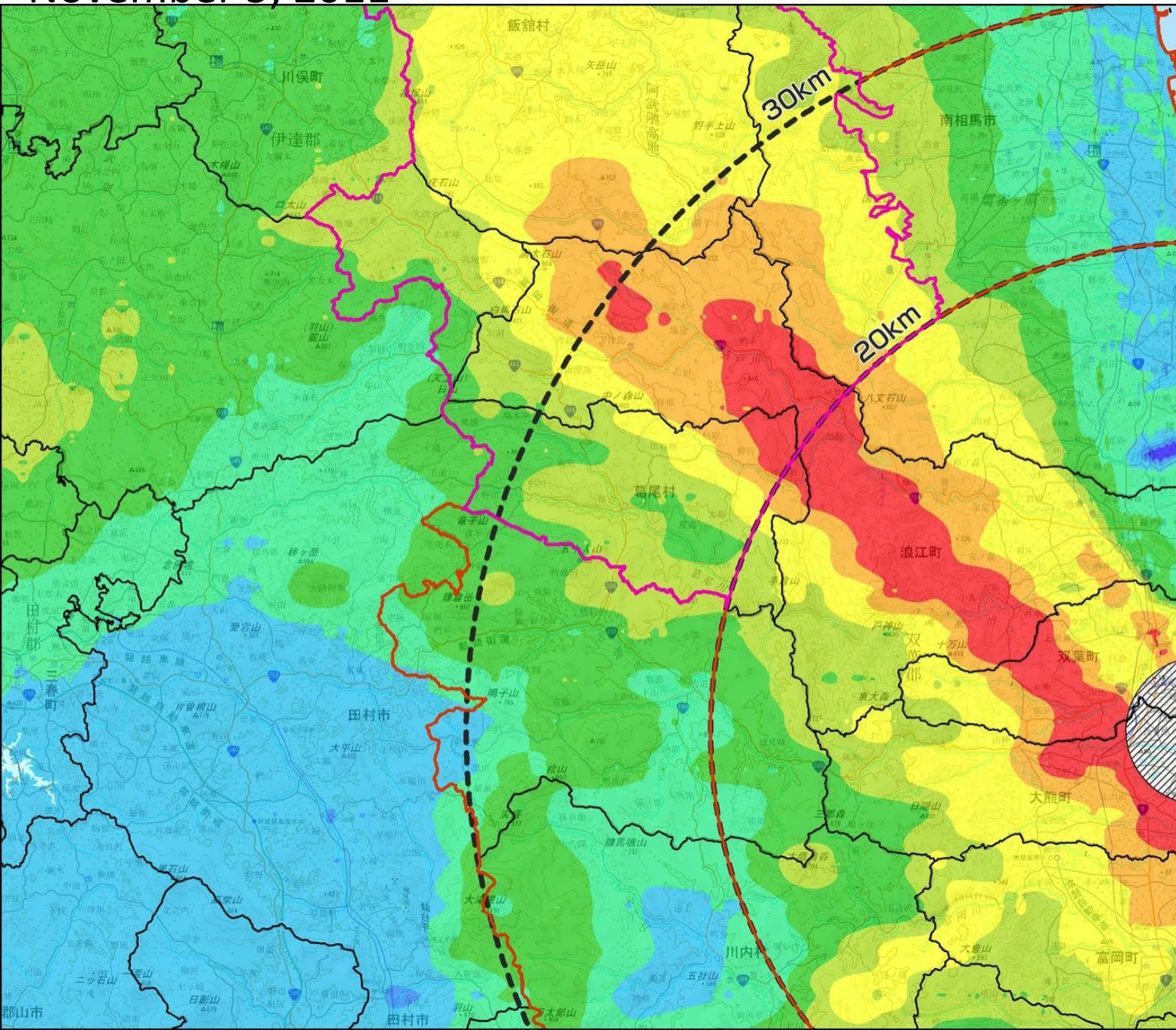

5640 - D

文部科学省 MINISTRY OF EDUCATION, CULTURE, SPORTS, SCIENCE AND TECHNOLOGY JAPAN

放射線量等分布マップ - 航空機モニタリング -

凡例

地表面から1mの高さの空間線量率 (μSv/h) [2011年11月5日現在の値に換算]

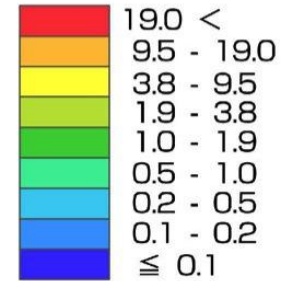

測定結果が得られていない範囲

※本マップには天然核種による空間線量率が含まれています。

計画的避難区域 (緊急時避難準備区域) (平成23年9月30日解除)

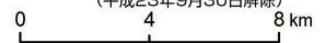

背景地図：電子国土

May 31, 2012

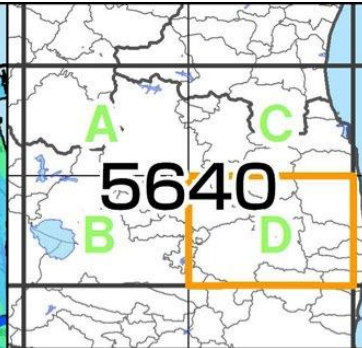
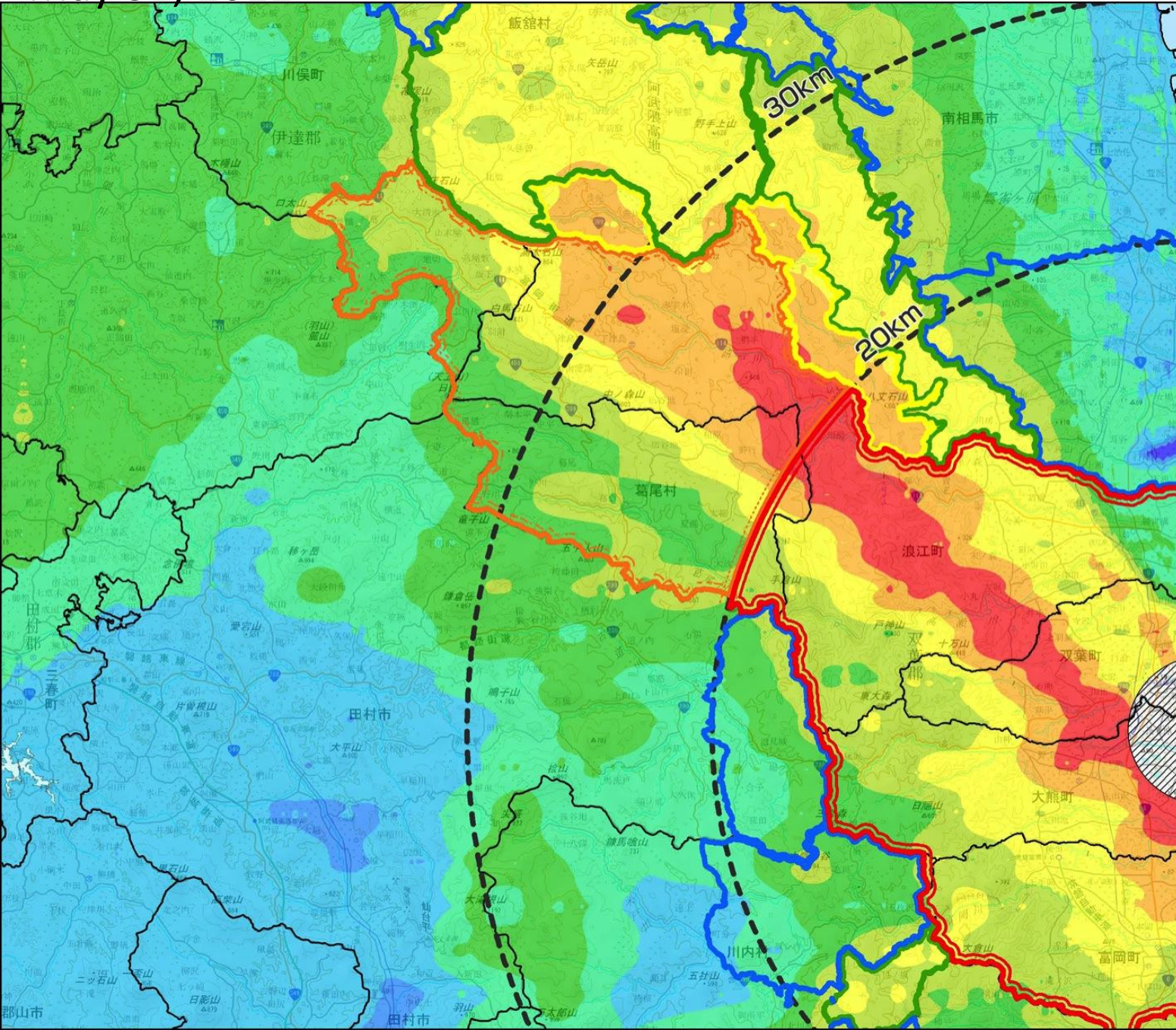

5640 - D

文部科学省 MINISTRY OF EDUCATION, CULTURE, SPORTS, SCIENCE AND TECHNOLOGY JAPAN

放射線量等分布マップ
- 航空機モニタリング -

凡例

地表面から1mの高さの空間線量率 ($\mu\text{Sv}/\text{h}$)
[2012年5月31日現在の値に換算]

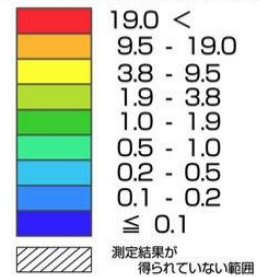

*本マップには天然核種による空間線量率が含まれています。

- 警戒区域
- 計画的避難区域
- 帰還困難区域
- 居住制限区域
- 避難指示解除準備区域 (2012年8月10日時点)

0 4 8 km

背景地図：電子国土

June 28, 2012

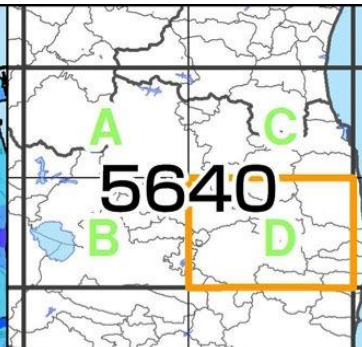
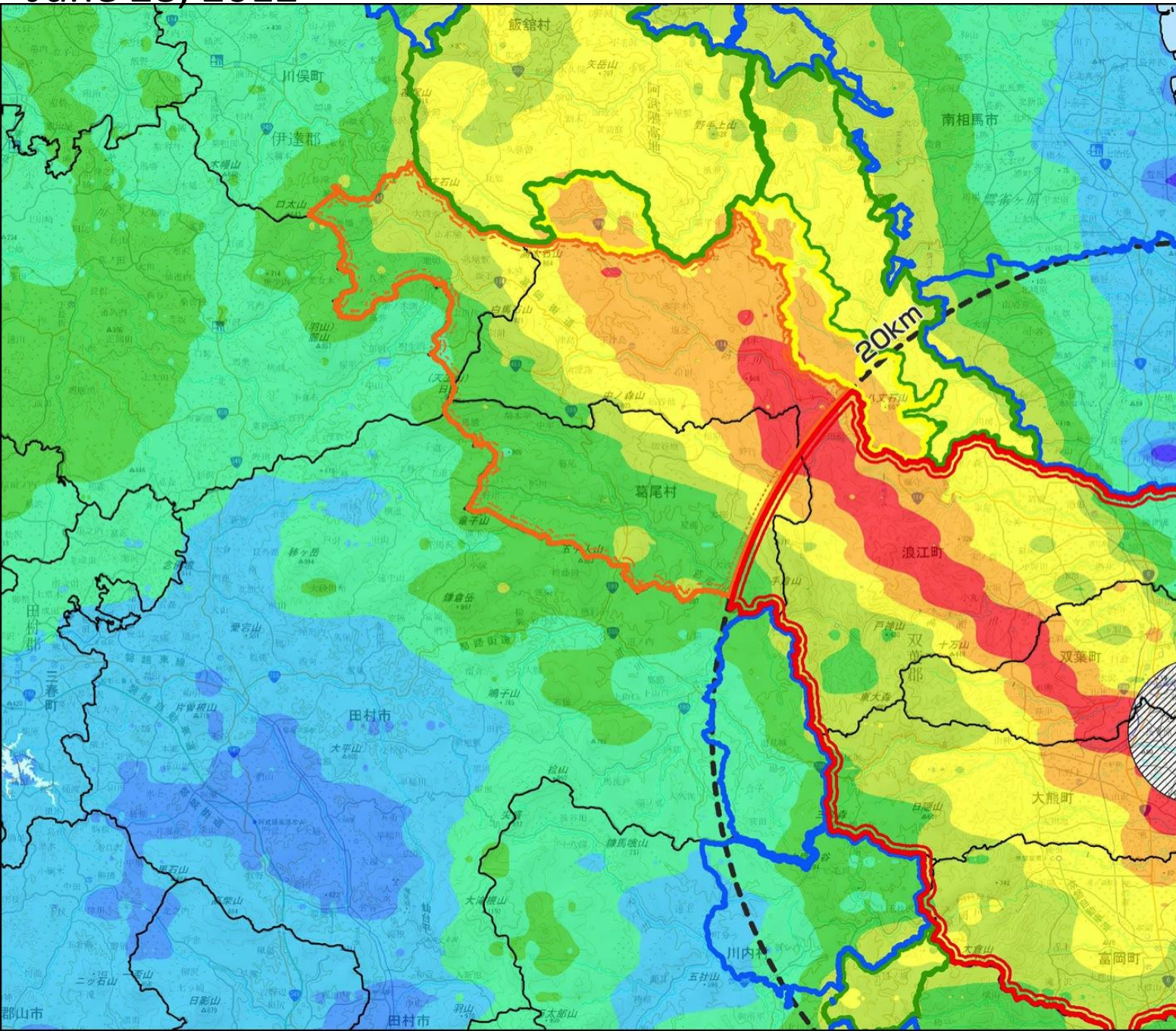

5640

5640 - D

文部科学省 MINISTRY OF EDUCATION, CULTURE, SPORTS, SCIENCE AND TECHNOLOGY JAPAN

放射線量等分布マップ - 航空機モニタリング -

凡例
 地表面から1mの高さの空間線量率($\mu\text{Sv/h}$)
 [2012年6月28日現在の値に換算]

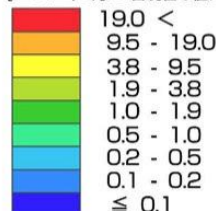

測定結果が得られていない範囲

積雪分布 (2012年3月26日~4月26日)

岩手県、宮城県、山形県、福島県、茨城県、栃木県、群馬県、千葉県を対象

JASMES: 宇宙航空研究開発機構 (JAXA)

* 本マップには天然核種による空間線量率が含まれています。
 * 福島第一原子力発電所から80km圏外の測定結果は、2012年5月7日の結果を2012年6月28日時点の値に換算しています。風向き等の自然環境による放射性物質の移行の影響は考慮していません。
 * 実線で囲われた白色の領域は積雪のあった箇所を表しており、当該地域及びその周辺における空間線量率は、雪の量により、雪が無い場合に比べて減少している可能性があります。

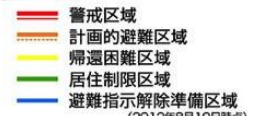

0 4 8 km

背景地図：電子国土

December 28, 2012

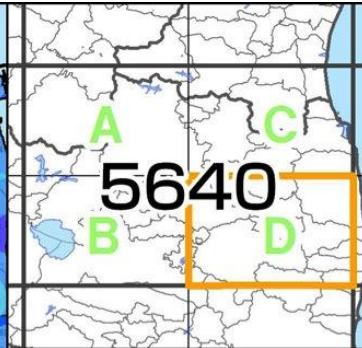
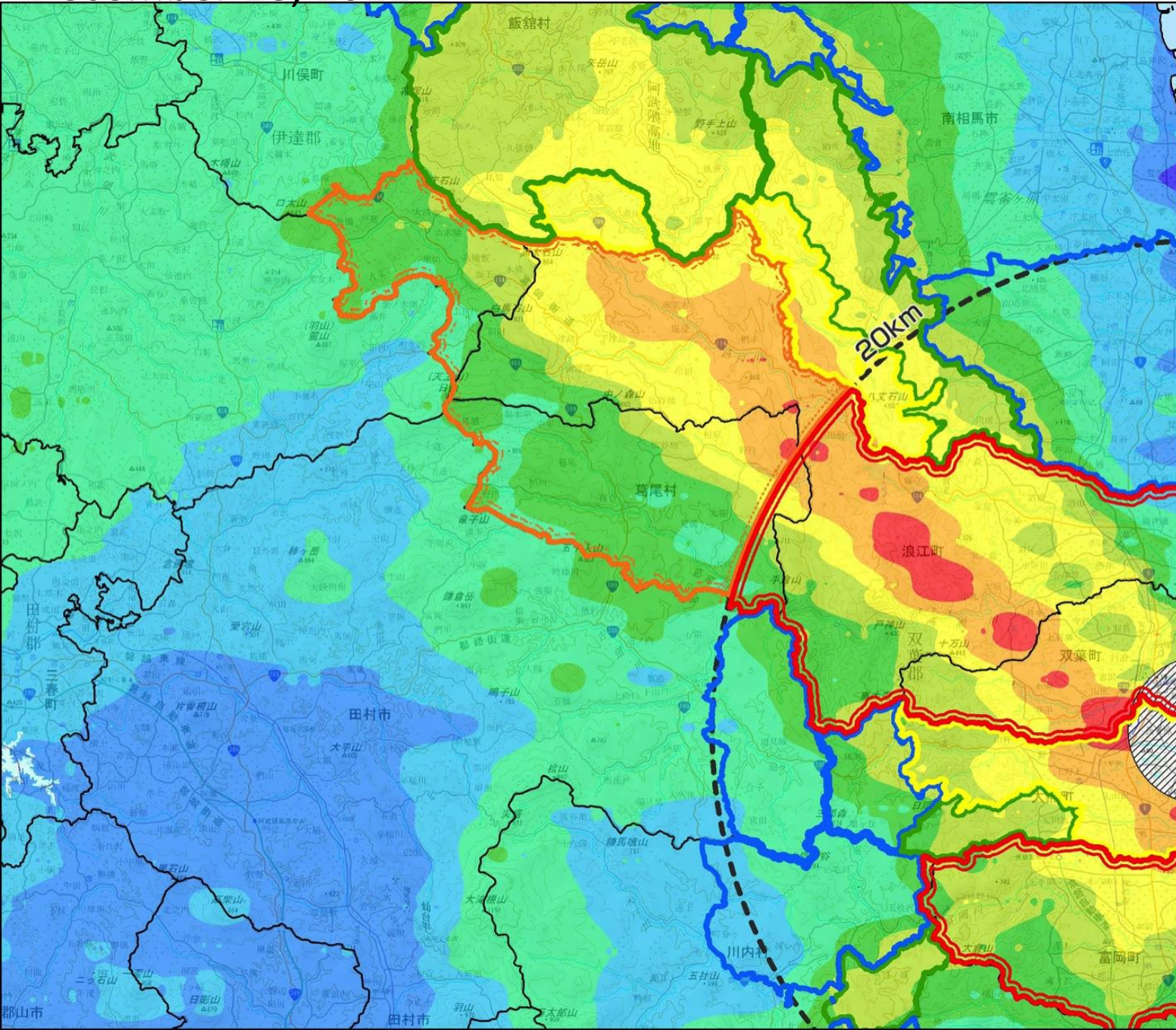

5640 - D

文部科学省 MINISTRY OF EDUCATION, CULTURE, SPORTS, SCIENCE AND TECHNOLOGY JAPAN

放射線量等分布マップ
- 航空機モニタリング -

凡例
地表面から1mの高さの空間線量率($\mu\text{Sv/h}$)
[2012年12月28日現在の値に換算]

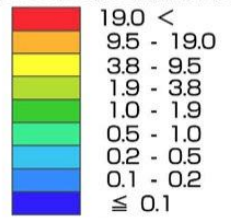

測定結果が得られていない範囲

積雪分布 (2012年11月1日~12月31日)

岩手県、宮城県、山形県、福島県、茨城県、栃木県、群馬県、千葉県を対象

JASMES: 宇宙航空研究開発機構 (JAXA)

* 本マップには天然核種による空間線量率が含まれています。
* 福島第一原子力発電所から80km圏内の測定結果は、2012年11月16日の結果を2012年12月28日現在の値に換算修正しています。風雨等の自然環境による放射性物質の移行の影響は考慮していません。
* 表紙で囲われた白色の領域は積雪のあった箇所を表しており、当該地域及びその周辺における空間線量率は、雪の遮蔽により、雪が無い時に比べて減少している可能性があります。

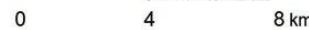
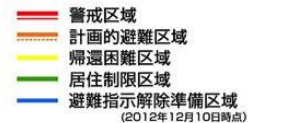

背景地図: 電子国土

September 28, 2013

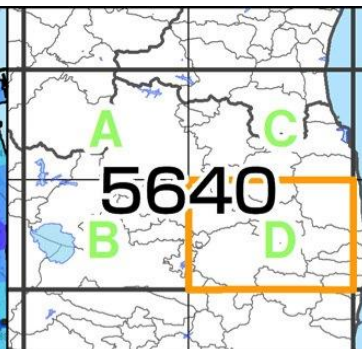
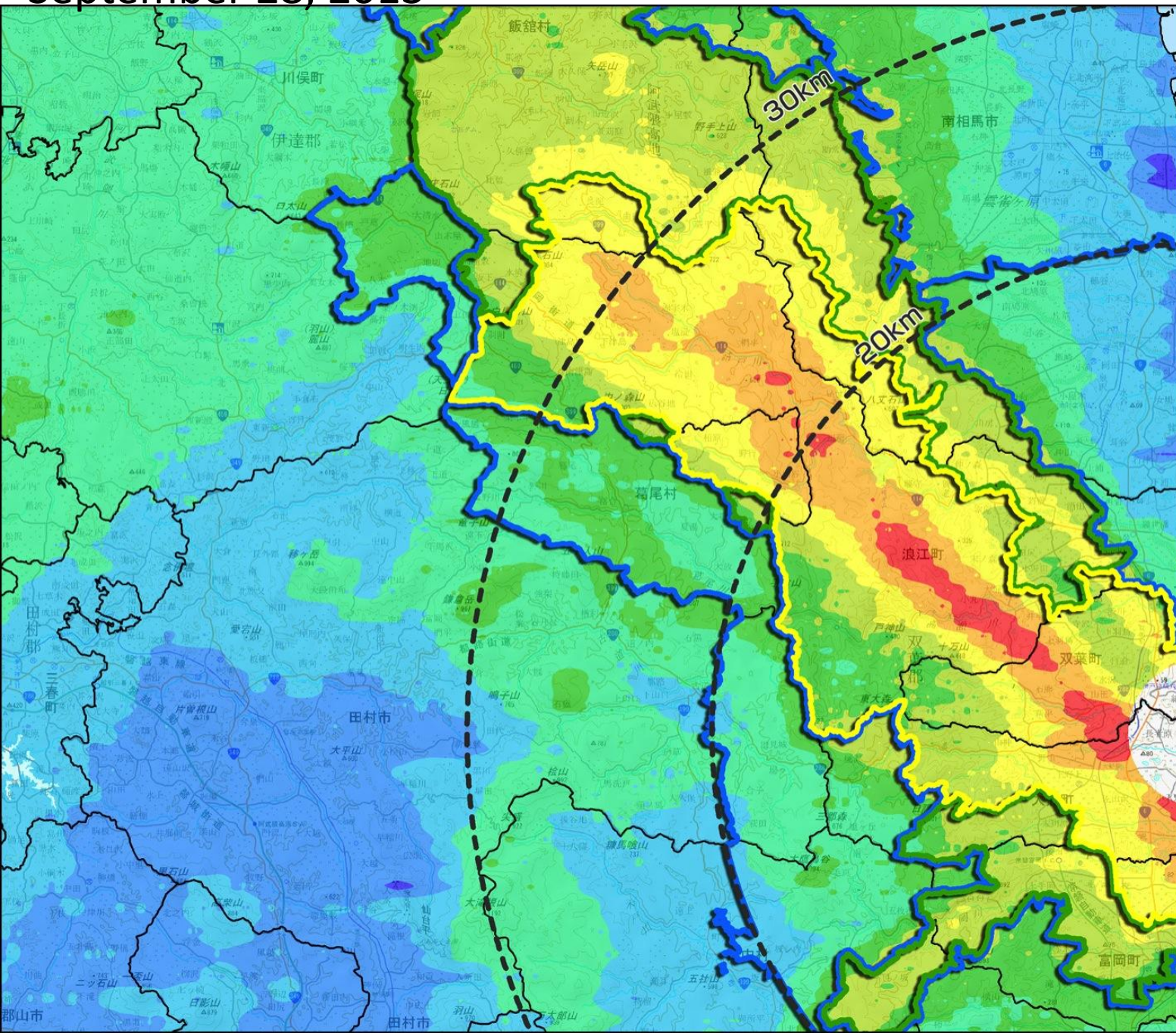

5640 - D

放射線量等分布マップ - 航空機モニタリング -

凡例
地表面から1mの高さの空間線量率($\mu\text{Sv/h}$)
[2013年9月28日現在の値に換算]

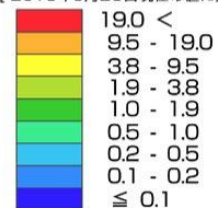

* 本マップには天然核種による空間線量率が含まれています。

- 帰還困難区域 (Yellow line)
- 居住制限区域 (Green line)
- 避難指示解除準備区域 (Blue line)
(2013年8月8日時点)



背景地図: 電子国土

November 19, 2013

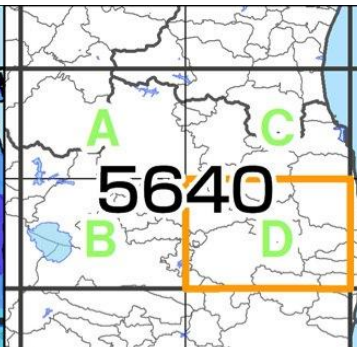
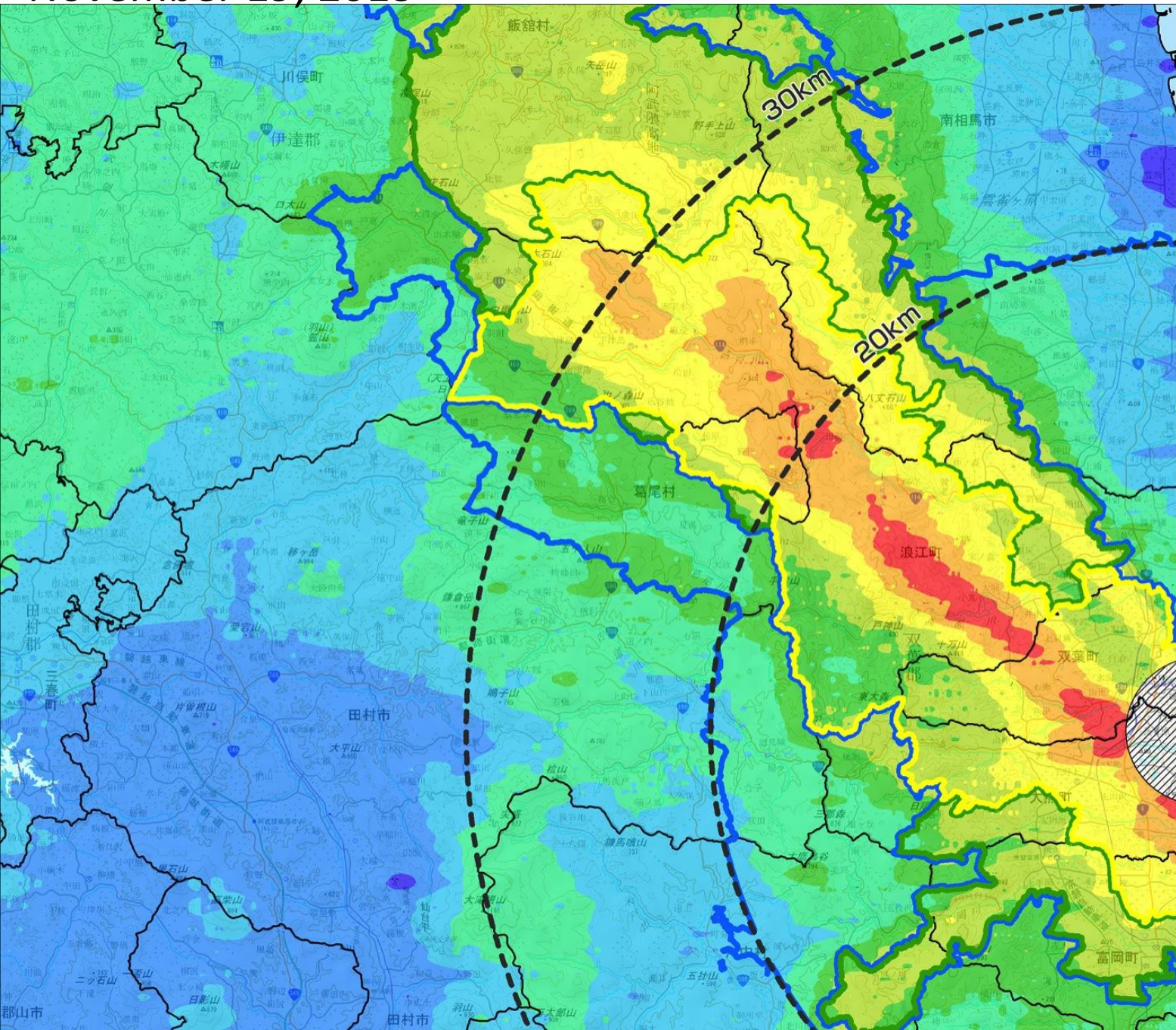

5640 - D

放射線量等分布マップ
- 航空機モニタリング -

凡例
地表面から1mの高さの空間線量率($\mu\text{Sv/h}$)
[2013年11月19日現在の値に換算]

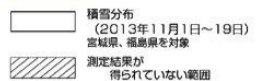
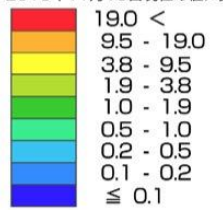

*1: 本マップには天然核種による空間線量率が含まれていません。
*2: 福島第一原子力発電所から80km圏外の測定結果は、事故32か月(平成25年11月19日時点)の値に減衰補正、風雨時の自然環境による放射能物質の付着の影響は考慮していません。
*3: 実施で出来なかった自治体の領域は斜線のあった箇所を表しています。

- 帰還困難区域
- 居住制限区域
- 避難指示解除準備区域 (2013年8月8日時点)

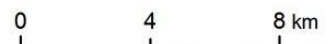

背景地図: 電子国土

Model for Decontamination and Waste Management

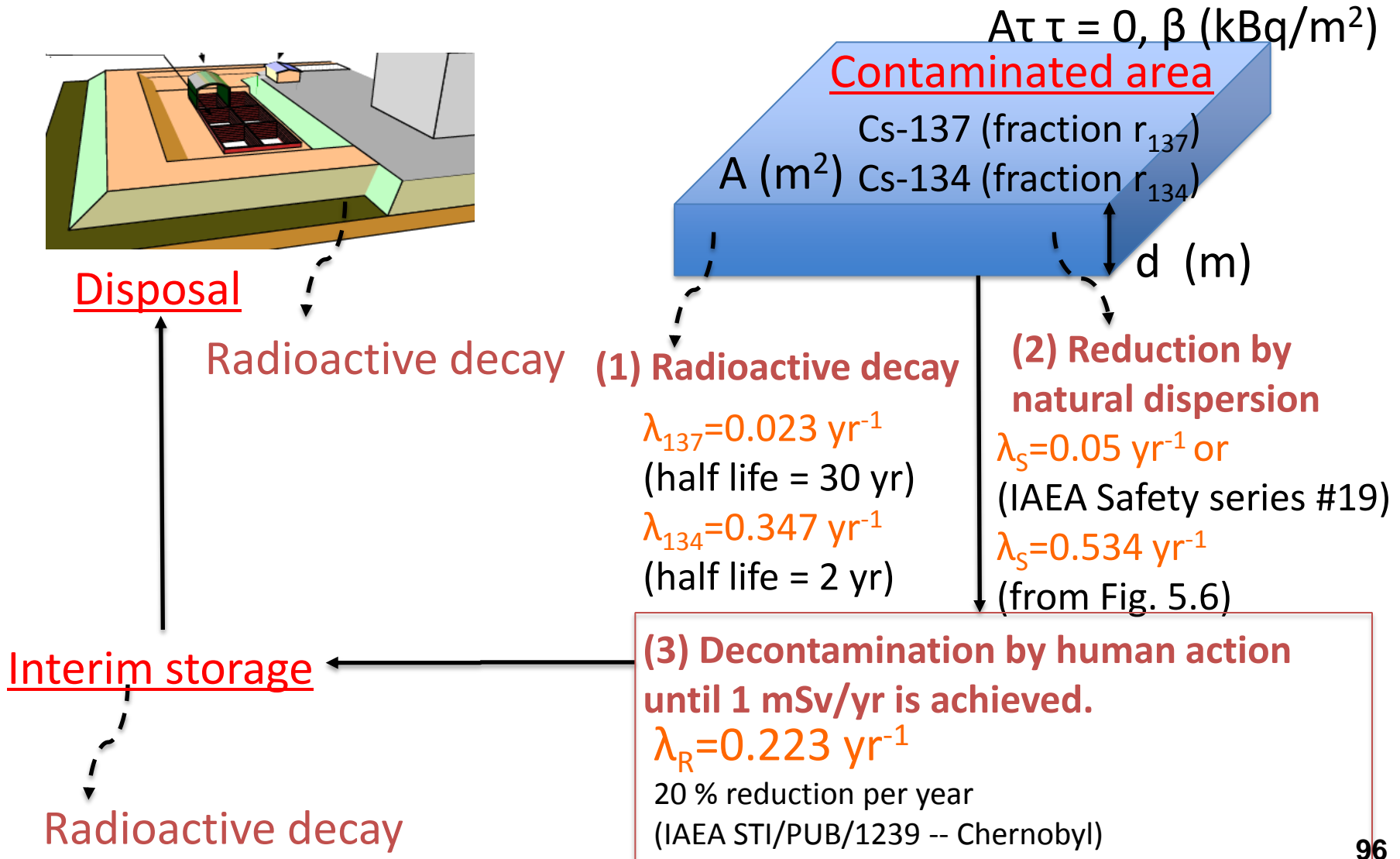

Recent Observations

Correlation between 2011/06 data and 2011/12 data

✓ Approximately 30% reduction in 6 months

• Observations

– Decrease by Radioactive Decay

- 17% decrease in 6 months

- Cs-134: Half life of 2 years

- Cs-137: Half life of 30 years

– Natural Dispersion

- 13%

- $\lambda=0.534 \text{ yr}^{-1}$

- Compare:

- $\lambda_s=0.05 \text{ yr}^{-1}$ (IAEA Safety series)

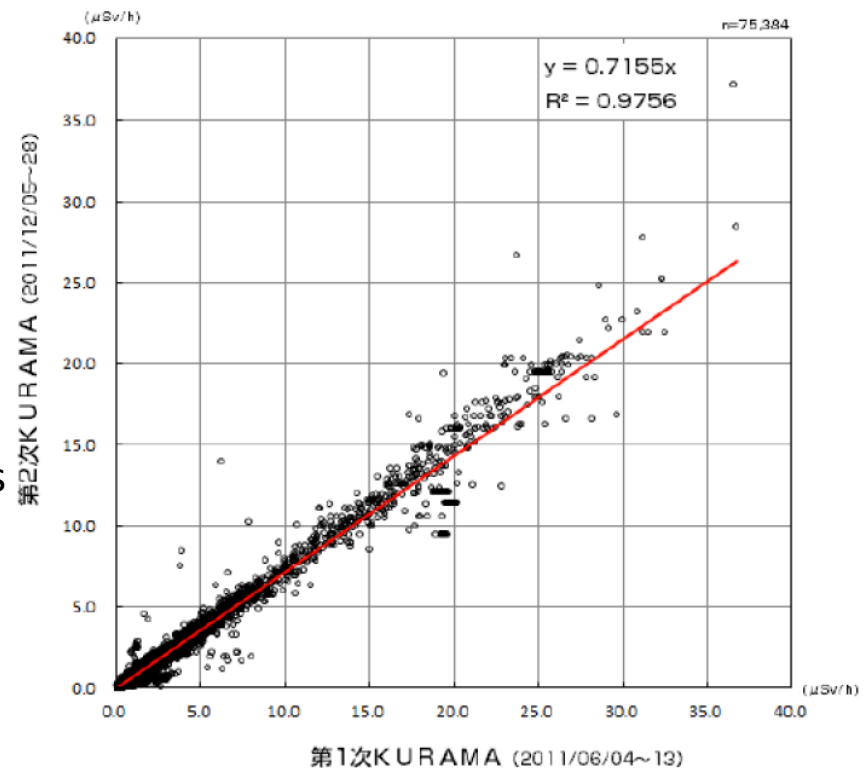

Effects of Decontamination and Natural Dispersion

Initial contamination (kBq/m ²)	Years to reach 20 mSv/yr				Years to reach 1 mSv/yr			
	No decontamination		With decontamination		No decontamination		With decontamination	
	Fast	Slow	Fast	Slow	Fast	Slow	Fast	Slow
> 3000	>1.43	>4.32	>1.10	>2.19	>5.67	>38.4	>4.25	> 9.83
1000 – 3000	0.90	2.52	0.70	1.36	5.06	32.8	3.81	8.62
600 – 1000	--	--	--	--	3.72	20.3	2.83	6.08
300 – 600	--	--	--	--	2.91	13.0	2.23	4.64
100 – 300	--	--	--	--	1.81	5.90	1.40	2.80
60 – 100	--	--	--	--	0.61	1.66	0.48	0.92

The goals set by the law:

- the annual dose is to be made less than 20 mSv/year within 2 years, and
- 1 mSv/year or lower at any location in the long term.

Fast: natural dispersion rate = 0.534 yr⁻¹

Slow: natural dispersion rate = 0.05 yr⁻¹

-- : air dose rates always below 20mSv/yr

Estimated Volume and Cost of Disposal for Radioactive Waste Arising from Decontamination

Initial soil contamination (kBq/m ²)	Area included (km ²)	Waste volume (million m ³)		Estimated cost (trillion yen)	
		<i>Fast dispersion</i>	<i>Slow dispersion</i>	<i>Fast dispersion</i>	<i>Slow dispersion</i>
> 3,000	183	5.6	8.1	3.6	5.3
1,000 – 3,000	368	10.5	15.7	6.8	10.2
Subtotal	551	16.1	23.8	10.5	15.5
600 – 1,000	282	6.6	10.5	4.3	6.8
300 – 600	721	14.1	23.2	9.2	15.1
Subtotal	1,003	20.7	33.7	13.5	21.9
Total	1,554	36.8	57.5	23.9	37.4

Time required for the air dose rate to become < 1 mSv/year

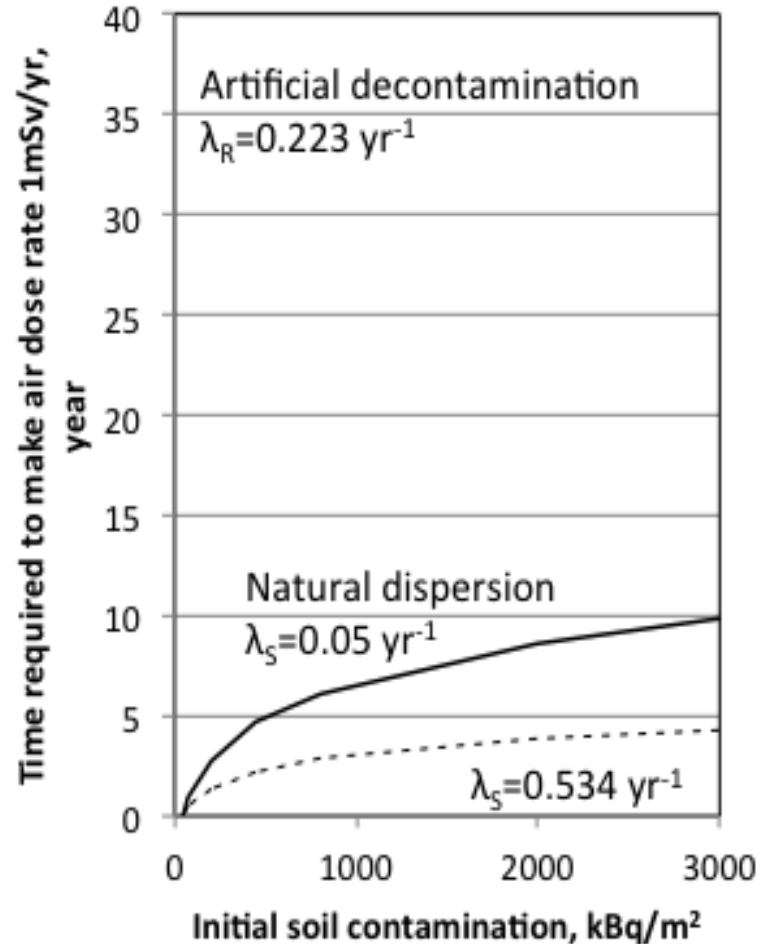
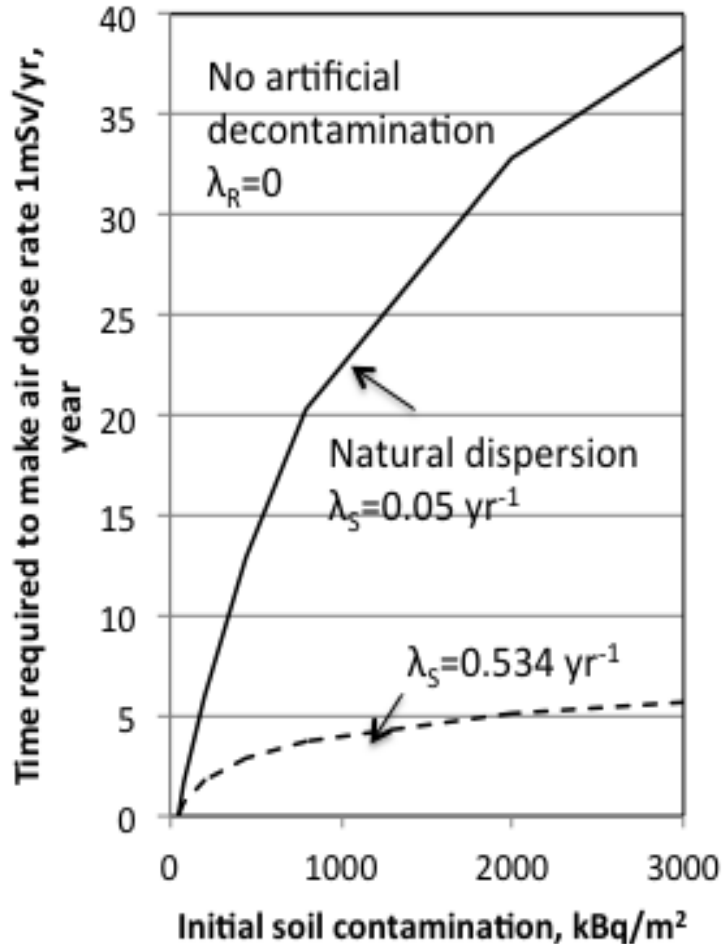

Summary of Fukushima Daiichi Nuclear Power Plant

	<i>Unit 1</i>	<i>Unit 2</i>	<i>Unit 3</i>	<i>Unit 4</i>	<i>Unit 5</i>	<i>Unit 6</i>
	BWR-3	BWR-4	BWR-4	BWR-4	BWR-4	BWR-5
PCV Model	Mark-I	Mark-I	Mark-I	Mark-I	Mark-I	Mark-II
Electric Output	460MWe	784MWe	784MWe	784MWe	784MWe	1100MWe
RPV Operation Pressure	6.89MPa	6.93MPa	6.93MPa	6.93MPa	6.93MPa	6.93MPa
RPV Max. Design Pressure	8.24MPa	8.24MPa	8.24MPa	8.24MPa	8.62MPa	8.62MPa
RPV Max. Operation Temp.	300°C	300°C	300°C	300°C	302°C	302°C
PCV Max. Design Pressure	384kPa	384kPa	384kPa	384kPa	384kPa	279kPa
PCV Max. Pressure *	427kPa	427kPa	427kPa	427kPa	427kPa	310kPa
PCV Max. Temp	140°C	140°C	140°C	140°C	138°C	171°C:D/W 105°C:S/C
Commercial Operation	1971.3.26	1974.7.18	1976.3.27	1978.10.12	1978.4.18	1979.10.24
Emergency DG	2	2 **	2	2 **	2	3 **
Electric Grid	275kV × 4				500kV × 2	
Plant Status on March 11, 2011	In Operation	In Operation	In Operation	Long Outage for Shroud Replacement	Refueling Outage	Refueling Outage

* Typical operating pressure of PCV is about 5 kPa.

** One Emergency DG is Air-Cooled **101**

*) The analysis results after the RPV rupture do not mean w ater levels are kept constant

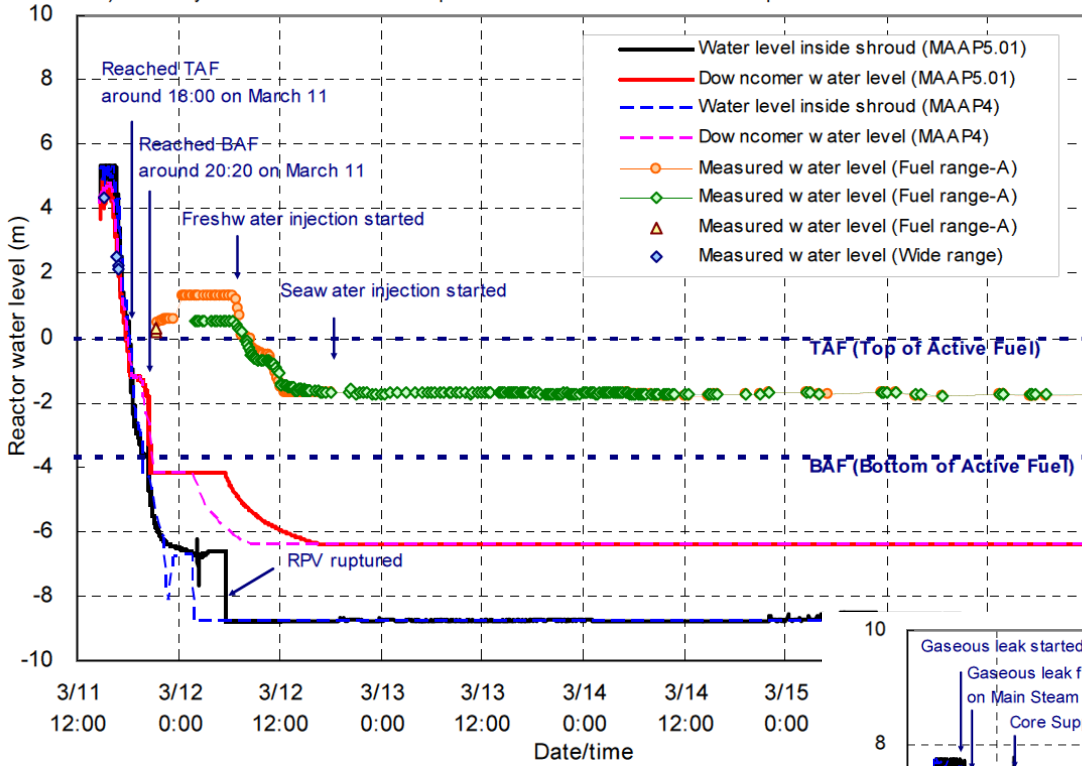

Unit 1

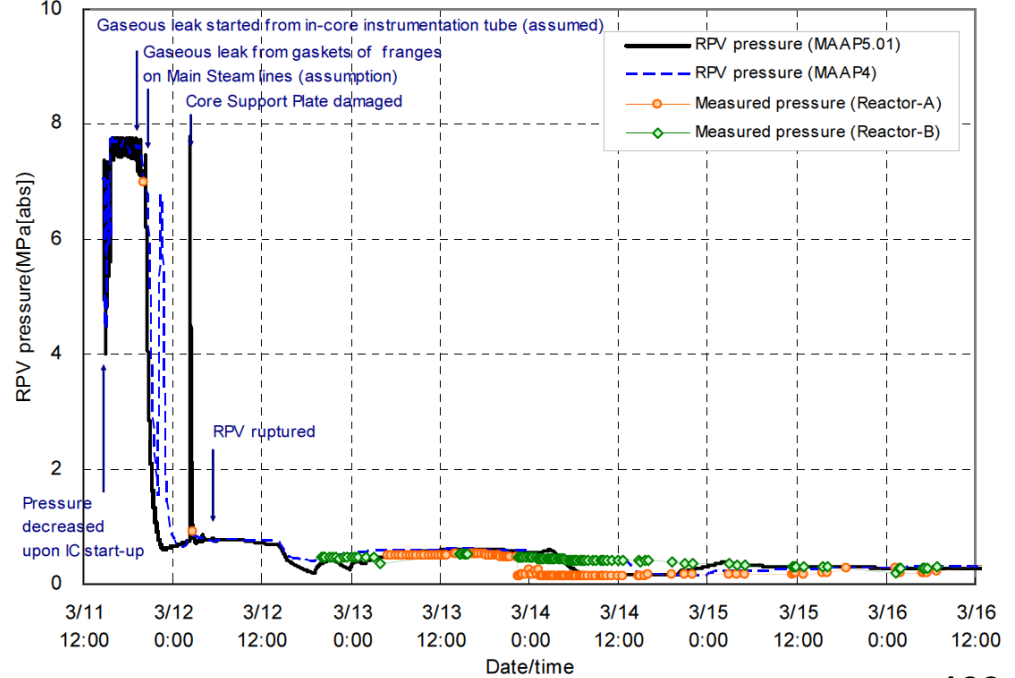

Unit 1

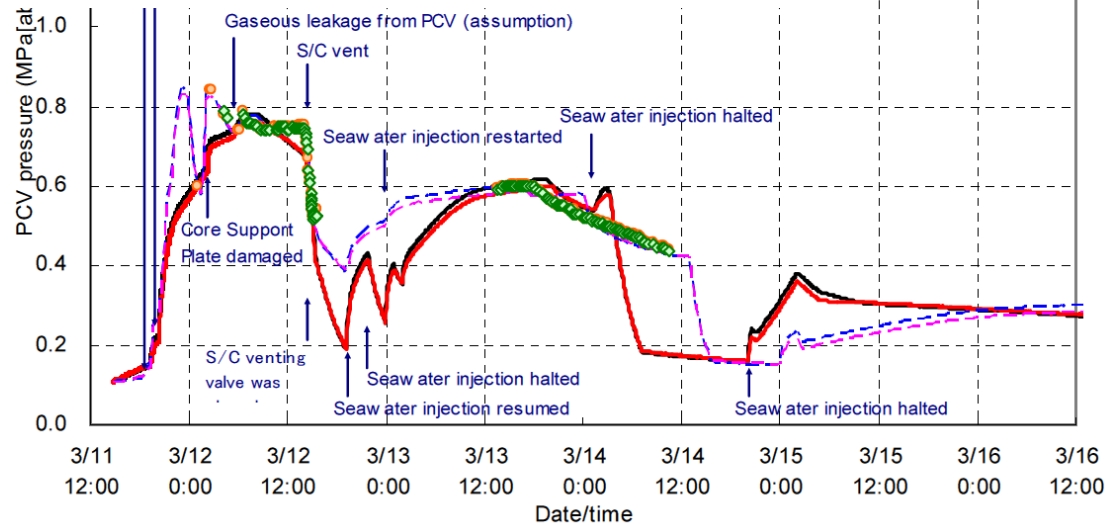
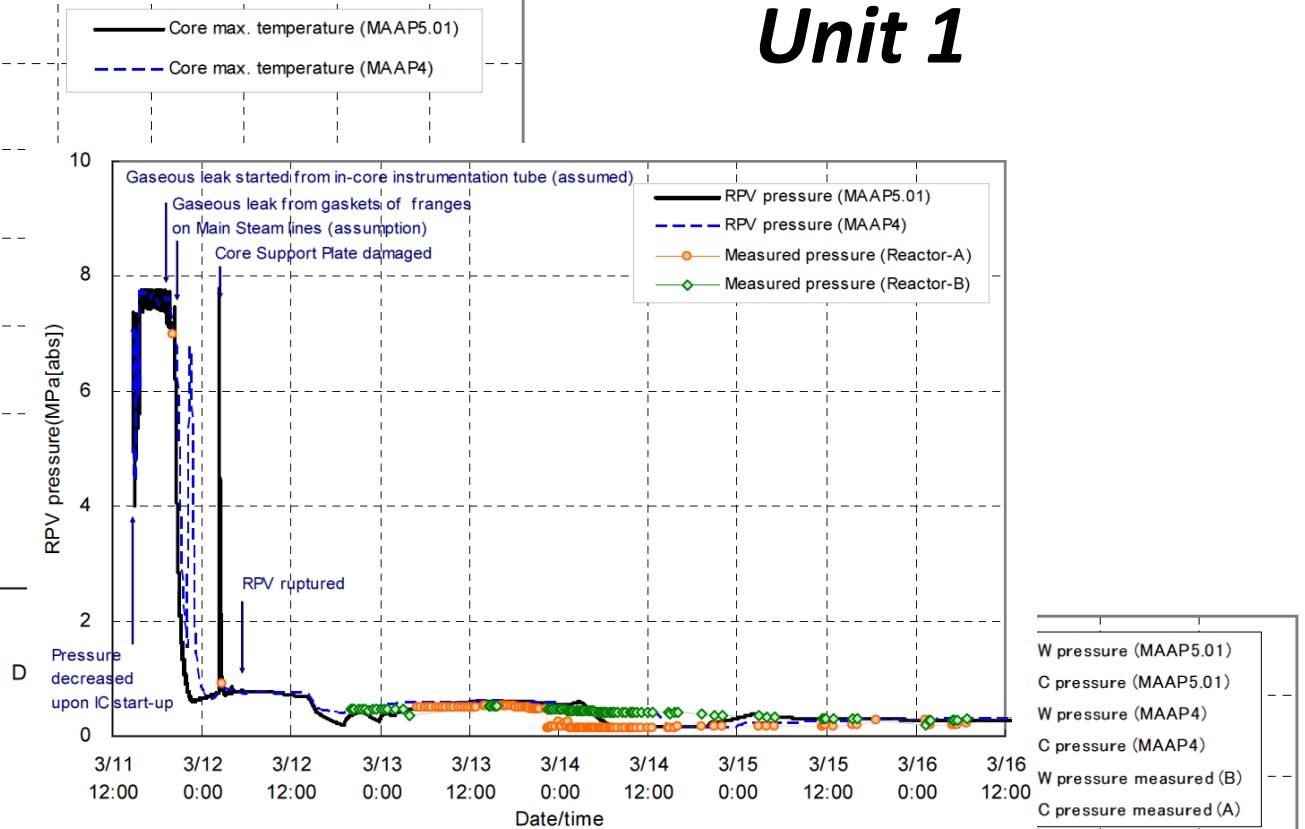
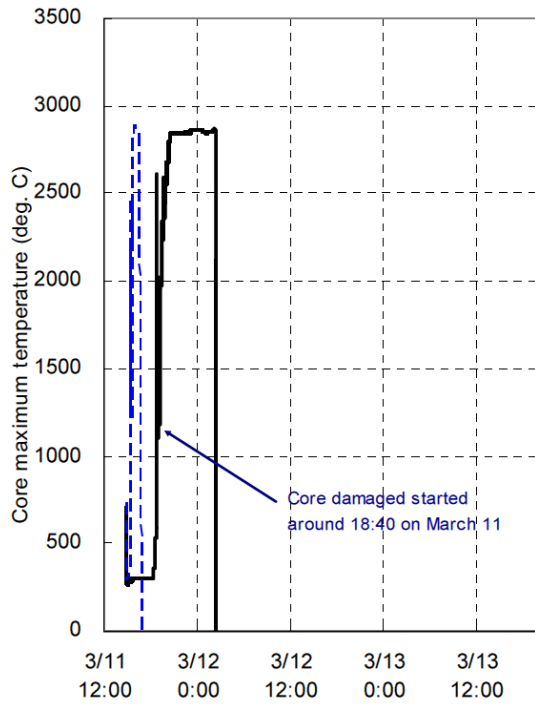

Unit 1

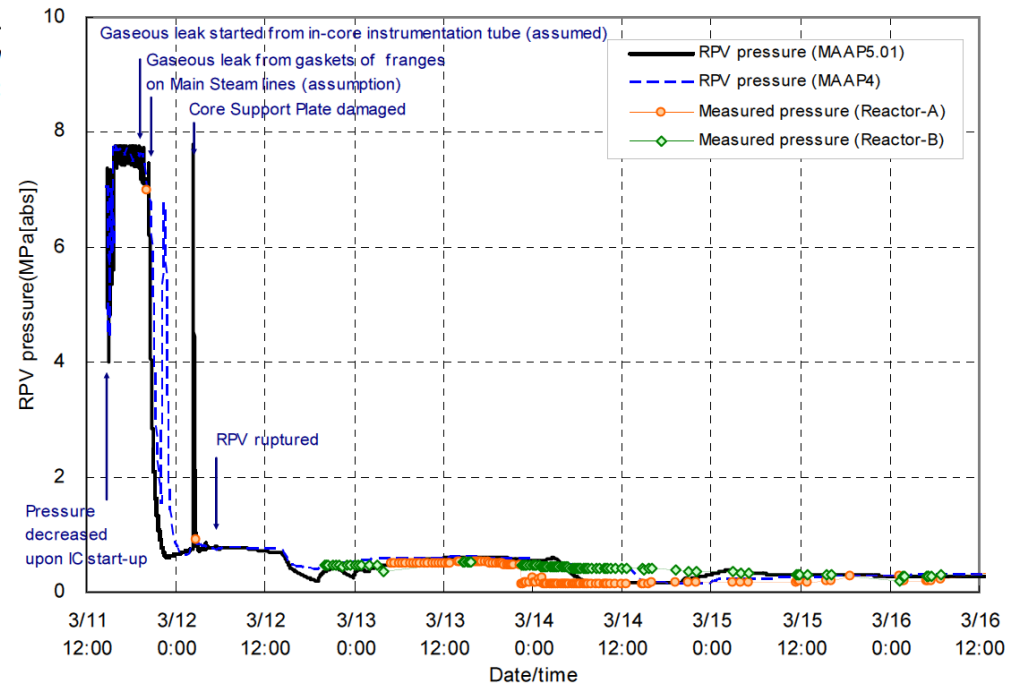
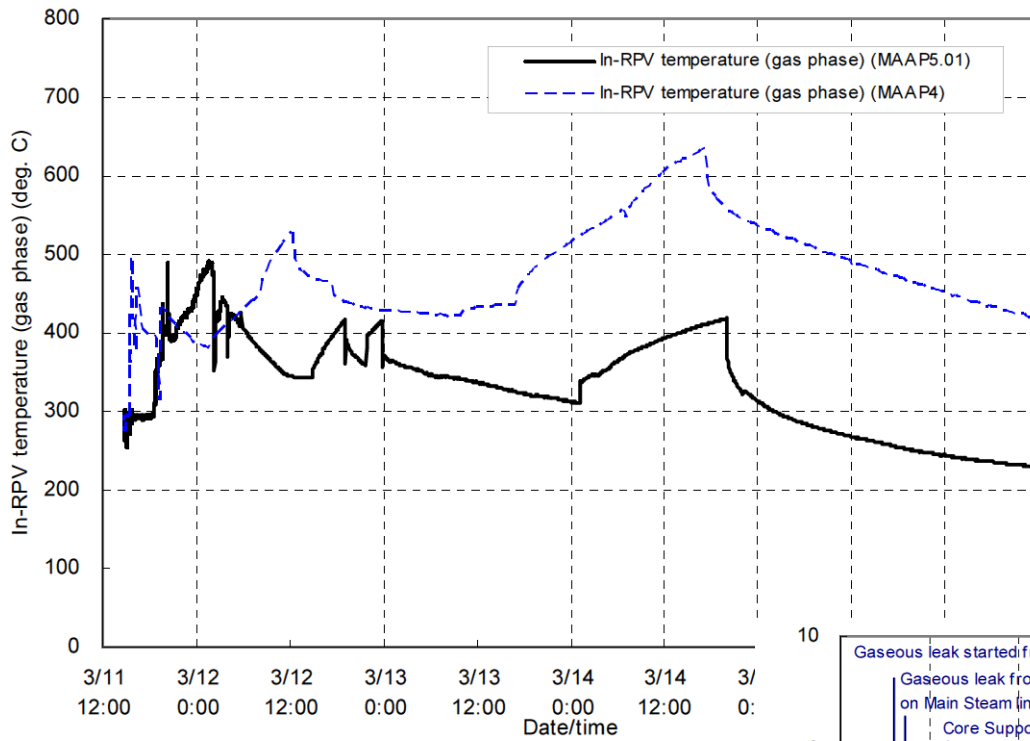

Release Rates of Fission Products in Various Chemical Forms in Unit 1

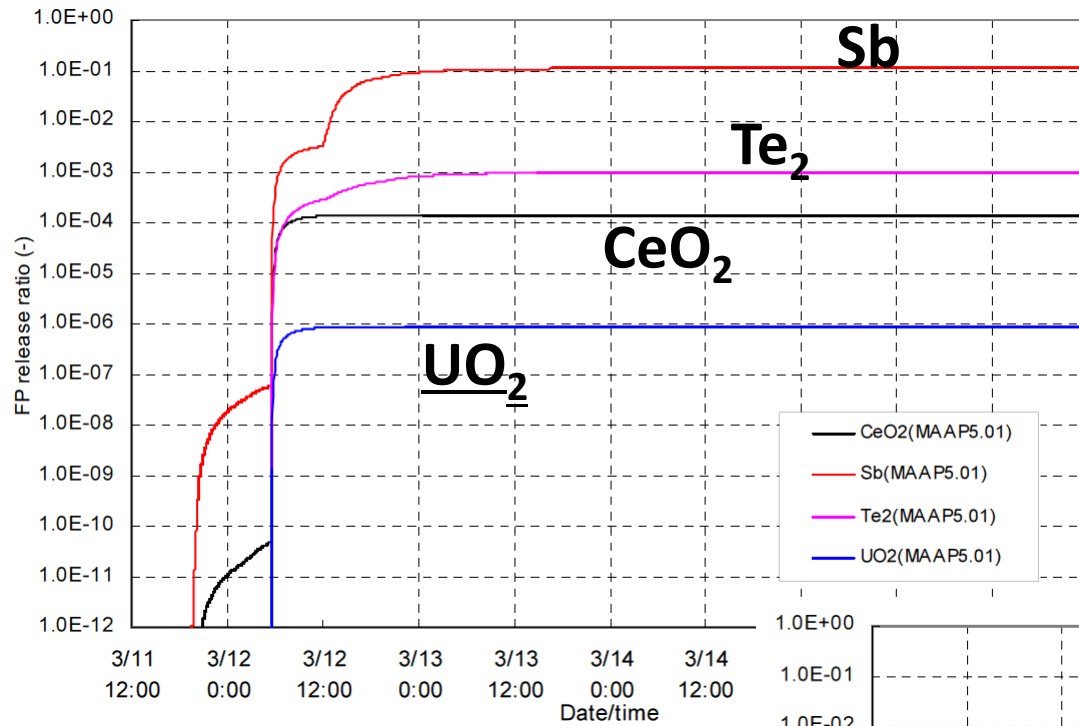

Unit 1

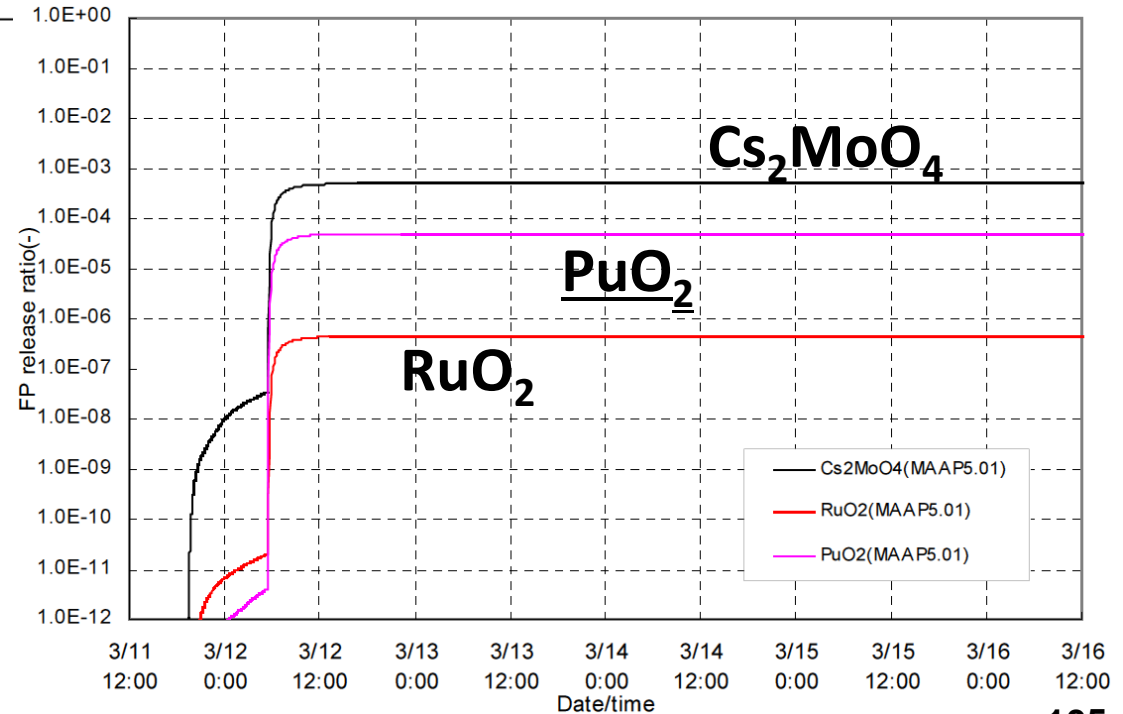

Release Rates of Fission Products in Various Chemical Forms in Unit 2 (MAAP code)

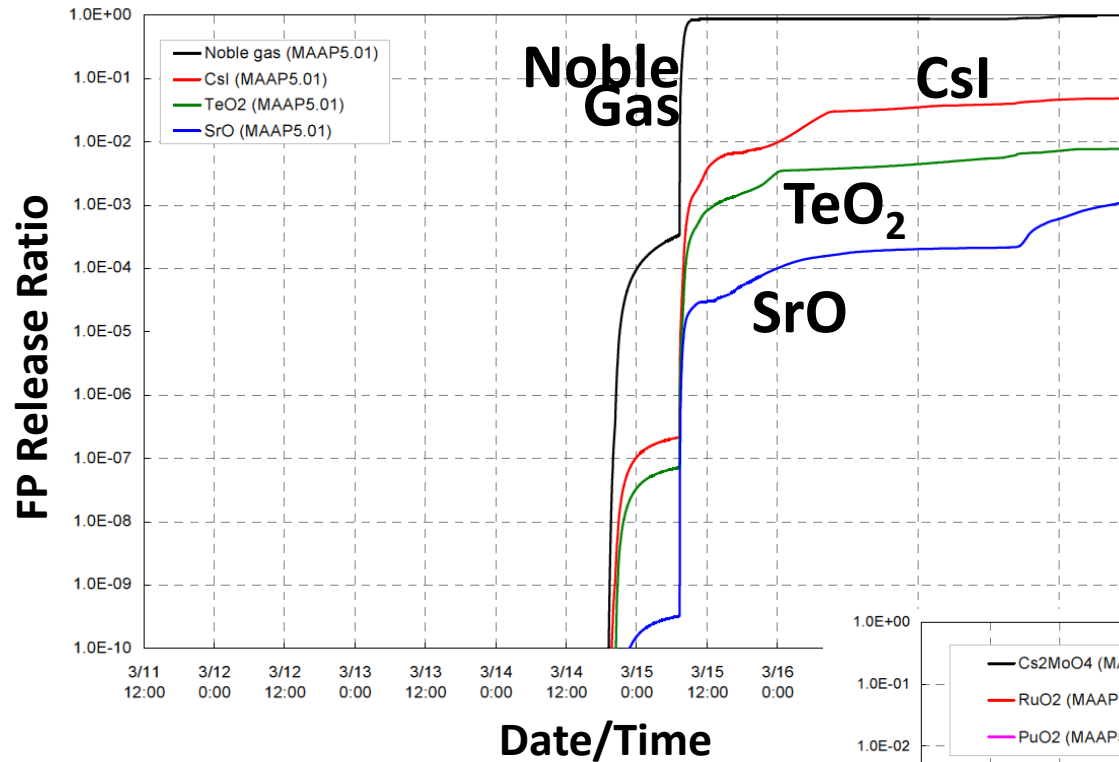

Unit 2

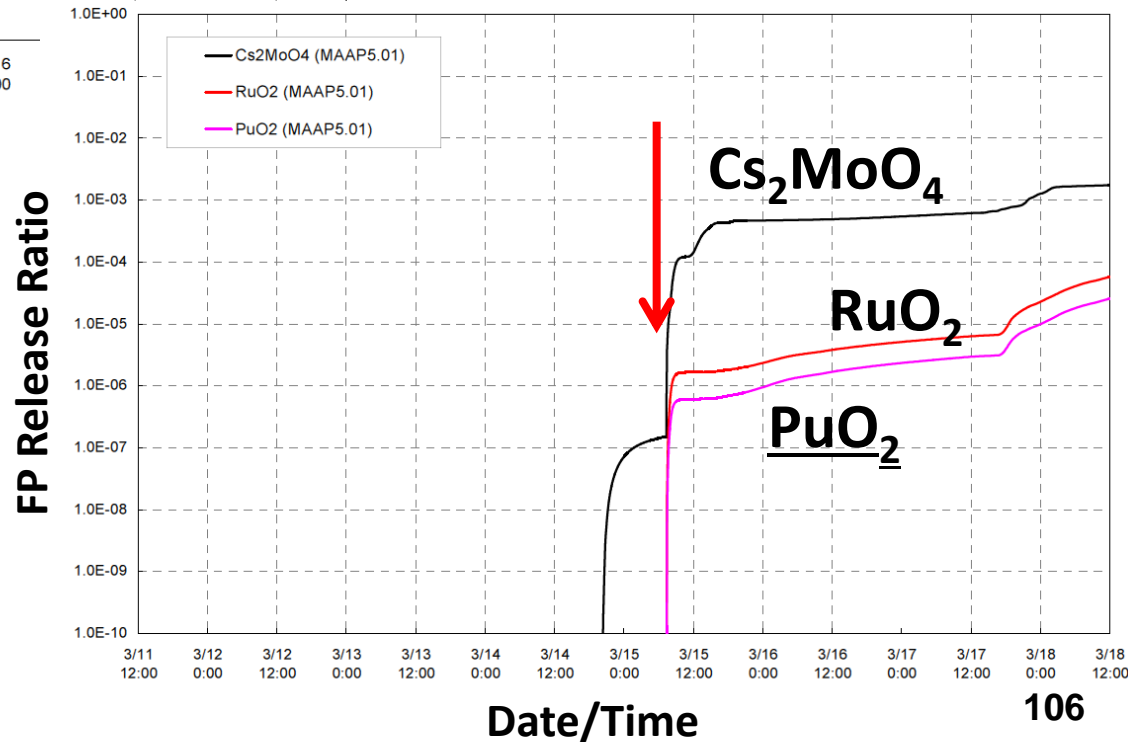

Investigation Result of the Inside of PCV of Unit 2

By investigations using an endoscope system, it was confirmed that:

- Water level in PCV is approx. 60 cm,
- Water temperature is approx. 50°C,
- and
- Dose rate of gas phase is 73 Sv/h.

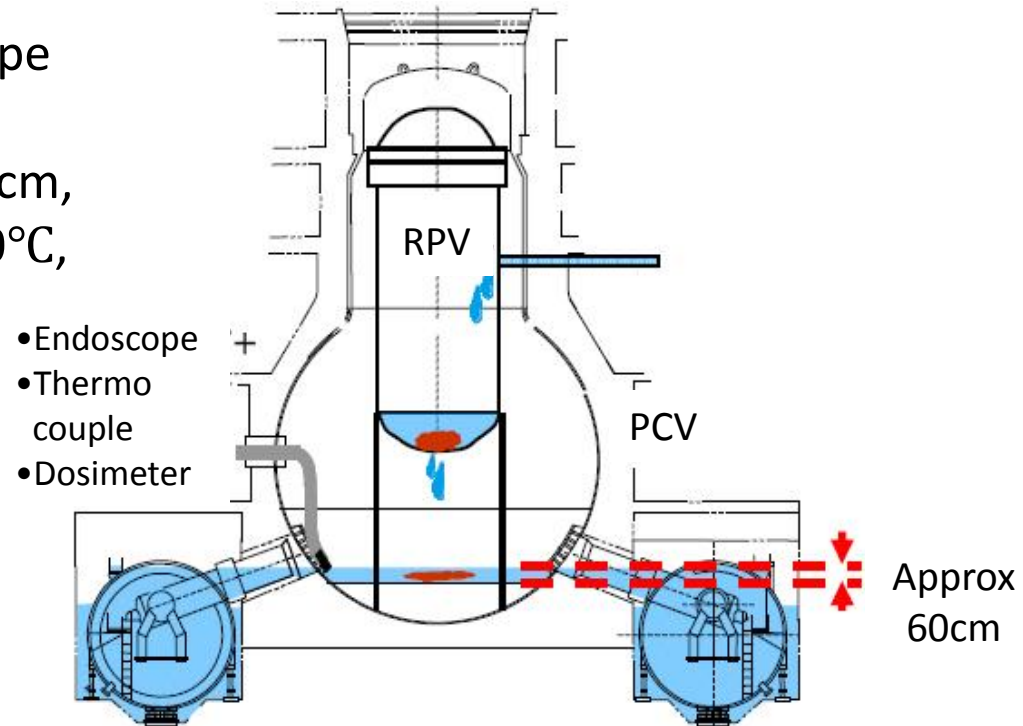

<Industrial endoscope of 20m>

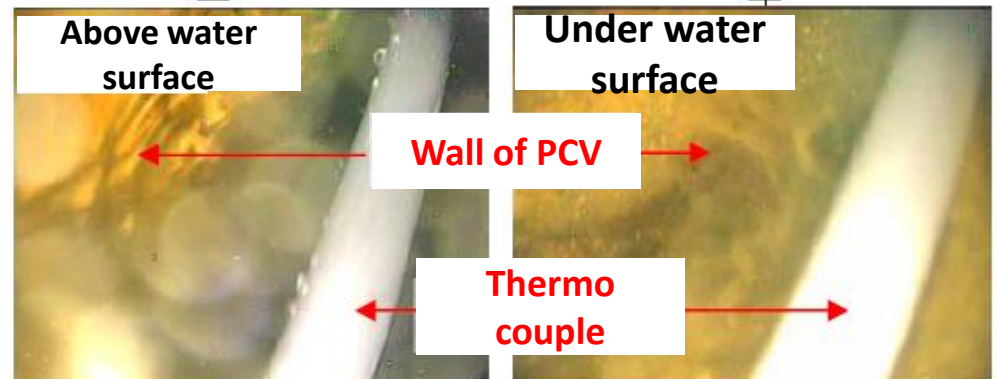
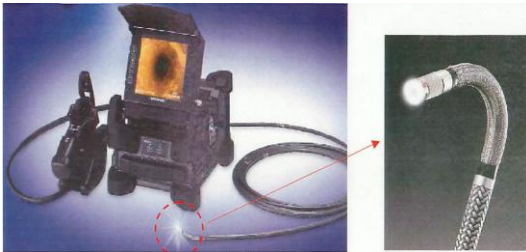

(Source: TEPCO)

Important Lessons Learned from Regulatory Points of View

- **Points to be addressed relevant to regulatory framework**
 - Enhancement of **Defense-in-Depth**
 - **Diversity, Flexibility and Operability** of Measures against Severe Accidents
 - Enhancement of **Consistency with International Standards and Practices**

- **Lessons learned as a regulatory organization**
 - **Lack of System Perusing Safety Enhancement**
 - **Needs for Feedback of Latest Knowledge and Findings, etc.**

Important Lessons Learned (1/2)

■ Design Basis Tsunami:

- DB-Ts was re-evaluated in 2002, but was seriously underestimated.
- New information such as Jyogan Tsunami (869) was not thoroughly considered.

⇒ Continuous efforts to **reduce uncertainty of external hazard** were needed.

■ Beyond Design Basis Tsunami :

- We should have been prepared for **Design Basis Tsunami being exceeded**. Such a risk exists even if the best efforts are made to determine DB-Ts. (preparation for “**Low likelihood, high consequence**” events)

⇒ Protection against **dynamic force** of tsunami, **water tightness** of doors, **diversity in layout** of equipment, etc., were needed to **prevent common cause failures (CCFs)**.

■ Protection against Severe Accidents (SAs):

- **Accident management (AM) measures** implemented against SAs were not effective. No AM measures had been taken for **spent fuel pools (SFPs)**

Important Lessons Learned (2/2)

■ **Emergency Preparedness and Responses:**

- Improvement of preparedness (communication, resources, etc.) assuming **combination of large-scale natural disasters and prolonged nuclear accident.**
- Enhancement of **environmental monitoring** for emergency
- Clarification of roles / responsibilities **between central and local organizations**
- many others

■ **Strengthening of Safety Culture:**

- We need to ask ourselves:
 - ✓ Were we vigilant enough to the plant vulnerabilities?
 - ✓ Were we careful enough for new technical findings?
- **There's no “continuous improvement of safety” without “safety culture”.**

Nuclear Power Plants in Japan

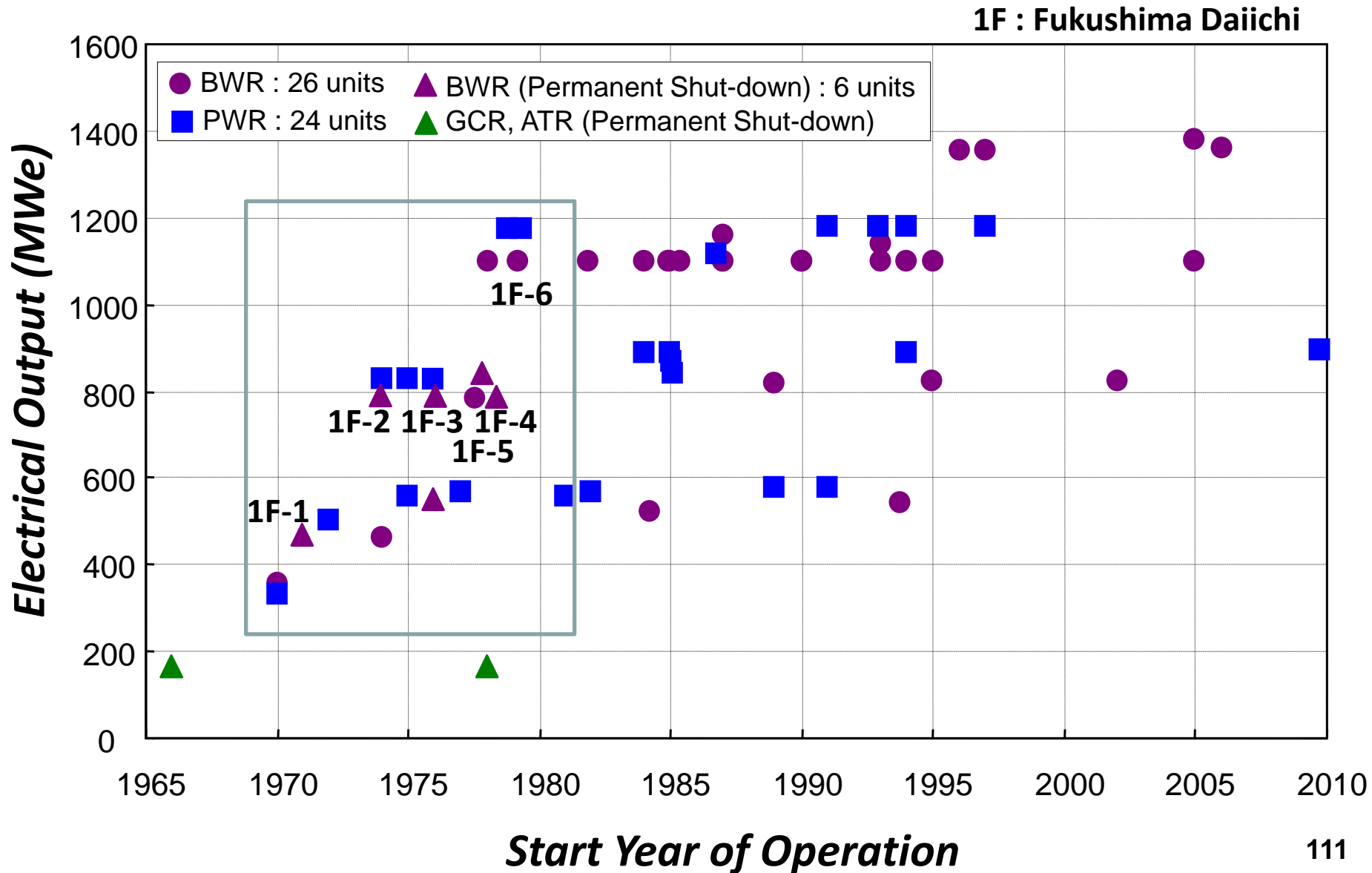

Effects of Ageing in the Fukushima Accident ?

- **As the results of the evaluation based on the knowledge obtained so far, it is quite unlikely that there was an effect of ageing degradation on loss of functions in SSCs important to safety due to the ground motion by the earthquake.**
- **It is also unlikely that ageing degradation phenomena have caused the occurrence and enlargement of the Fukushima Daiichi accident.**
- **However, as it is difficult to confirm the status of equipment at this moment, additional investigation will be needed, when new knowledge is obtained in the future.**

**Report of the Expert Meeting on Ageing Management in NISA
(February 7, 2012)**

Maximum Acceleration Observed in Fukushima Daiichi

Location of Seismometer (bottom floors of the reactor buildings)		Records			Max. Response Acceleration to the Design Basis Ground Motion, S _s (Gal)		
		Max. Acceleration (Gal)			NS	EW	UD
		NS	EW	UD			
Fukushima Daiichi	Unit 1	460※ ¹	447※ ¹	258※ ¹	487	489	412
	Unit 2	348※ ¹	550※ ¹	302※ ¹	441	438	420
	Unit 3	322※ ¹	507※ ¹	231※ ¹	449	441	429
	Unit 4	281※ ¹	319※ ¹	200※ ¹	447	445	422
	Unit 5	311※ ¹	548※ ¹	256※ ¹	452	452	427
	Unit 6	298※ ¹	444※ ¹	244	445	448	415

※¹: Each recording was interrupted at around 130-150(s) from recording start time

※²: 1 Gal=0.01m/s² , 981 Gal=1G

Source: Added to “The impact of the 2011 off the Pacific coast of Tohoku Earthquake to Nuclear Reactor Facilities at Fukushima Dai-ichi Nuclear Power Station” (Sep. 9, 2011, revised Sept. 28, 2011, TEPCO)

Evaluation of Additional Effect of the Earthquake on Low Cycle Fatigue of Main Steam Line Piping of Unit 1

Cumulative Fatigue Coefficient for 60 years	Fatigue Coefficient considering Earthquake		
	Due to Seismic Load		Total
0.064	S_2	0.252	0.316
	S_s	0.269	0.333
	Earthquake on March 11, 2011	0.264	0.328

Equivalent number of cycle due to seismic load is conservatively assumed to be 100.
 S_2 , S_s : Design basis seismic ground motion

Evaluation of Effect of the Earthquake on March 11, 2011 on Structural Integrity of Important Pumps considering General Corrosion of Anchor Bolts

	Pumps Evaluated	Shear Stress [MPa]		Allowable Stress [MPa]
		Without Corrosion	With Corrosion for 60 years	
Unit 1	Reactor Shut Down Cooling System Cooling Pumps	8	9	127
Unit 2	Residual Heat Removal System Pumps	34	36	202
Unit 3	Residual Heat Removal System Pumps	23	24	202

- The corrosion of the anchor bolts was evaluated by multiplication of cross-section decrease rate (6.0%/y) in consideration of the corrosion amount for 60 years of 0.3 mm.
- The shear stress with consideration of the amount of corrosions for 60 years was confirmed that there was sufficient margin to the allowable stress.

Summary of the 10-Unit Simultaneous Accidents

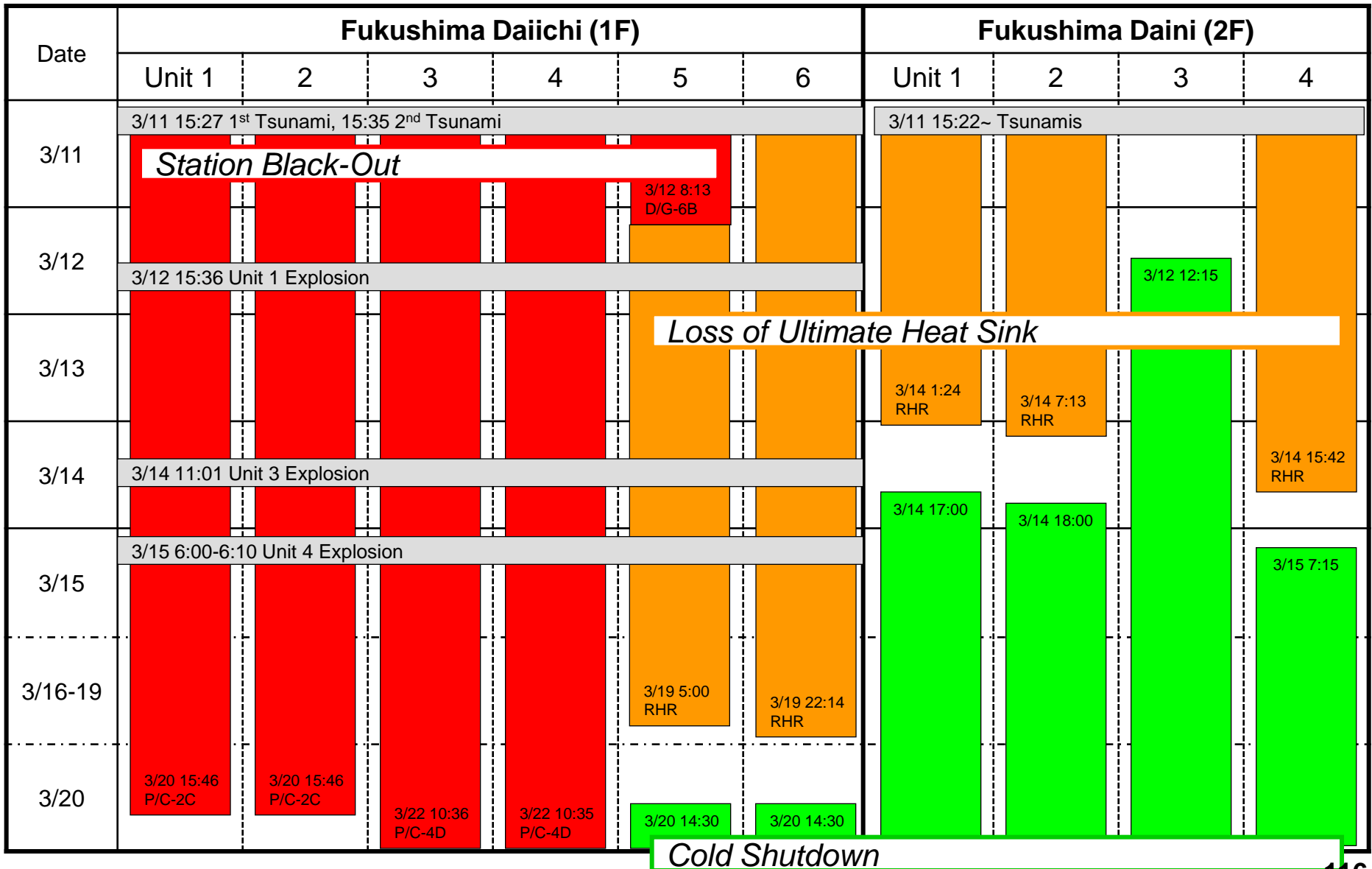

Macroscopic Balance between Decay Heat and Heat Removal in Unit 1

Decay Heat > Heat Removal

- Total decay heat before sea water injection greatly exceeds the amount of heat which reactor water and structural materials could absorb.
- All molten core moved to RPV bottom and they damaged RPV and run down to PCV.

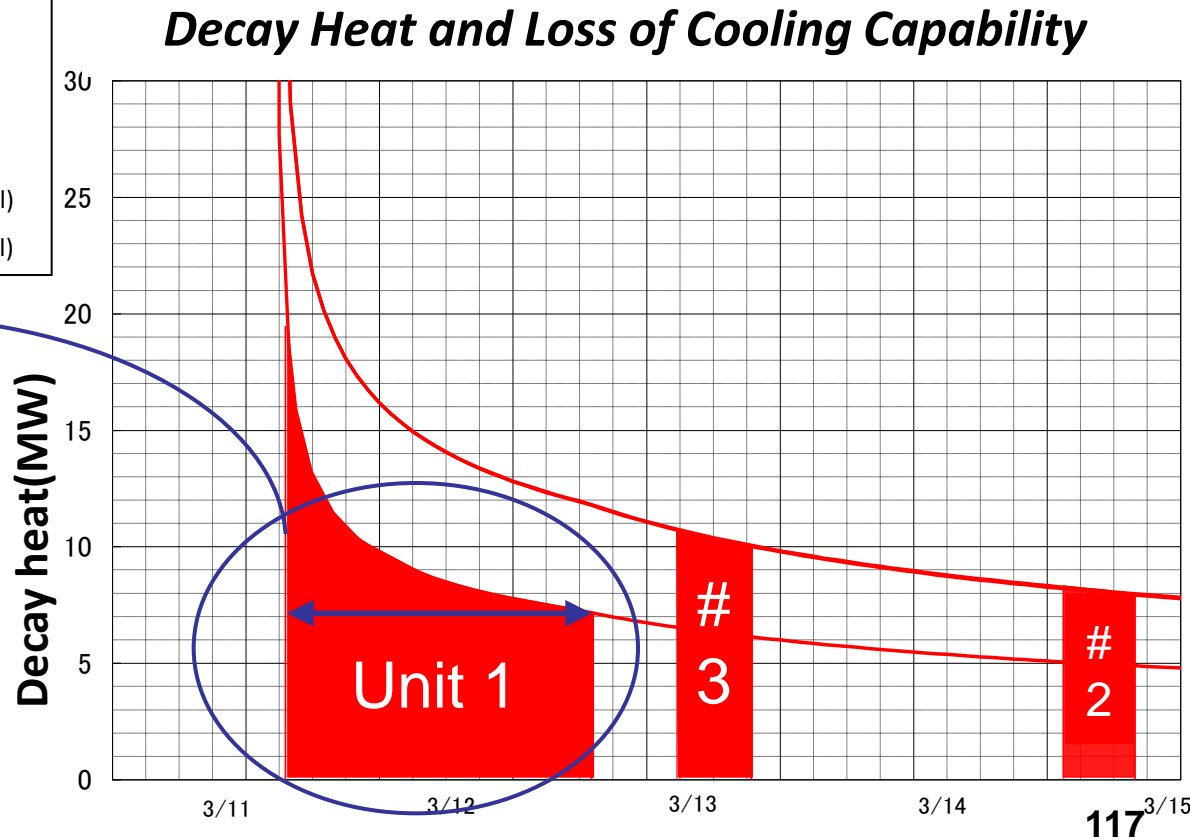
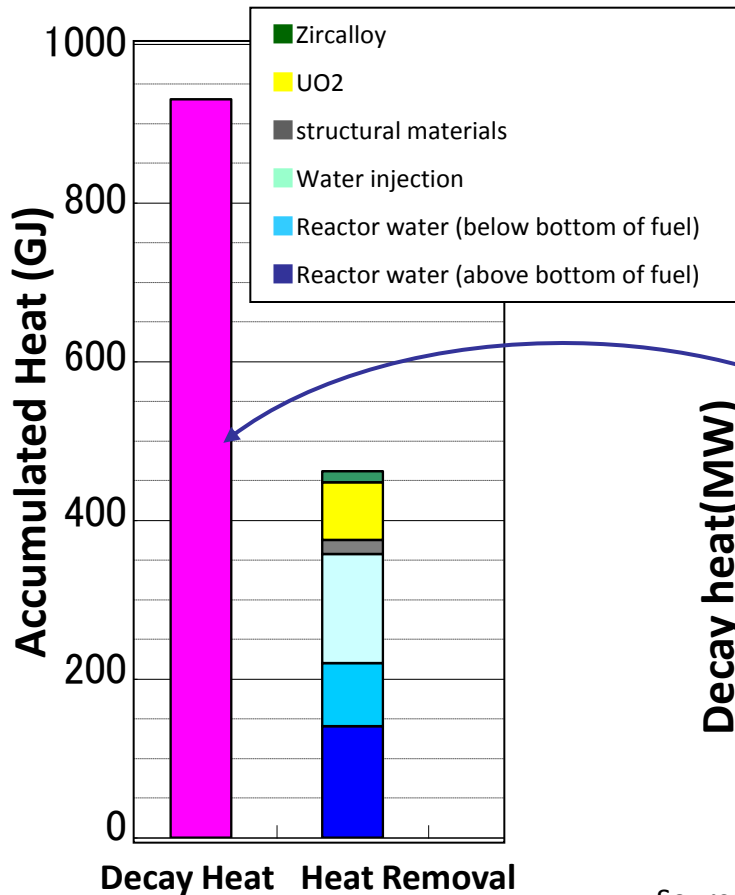

Reactor Water Level and Core Temperature in Unit 1

- Simulation Trial by the MAAP code -

Assuming that IC lost its function by the Tsunami

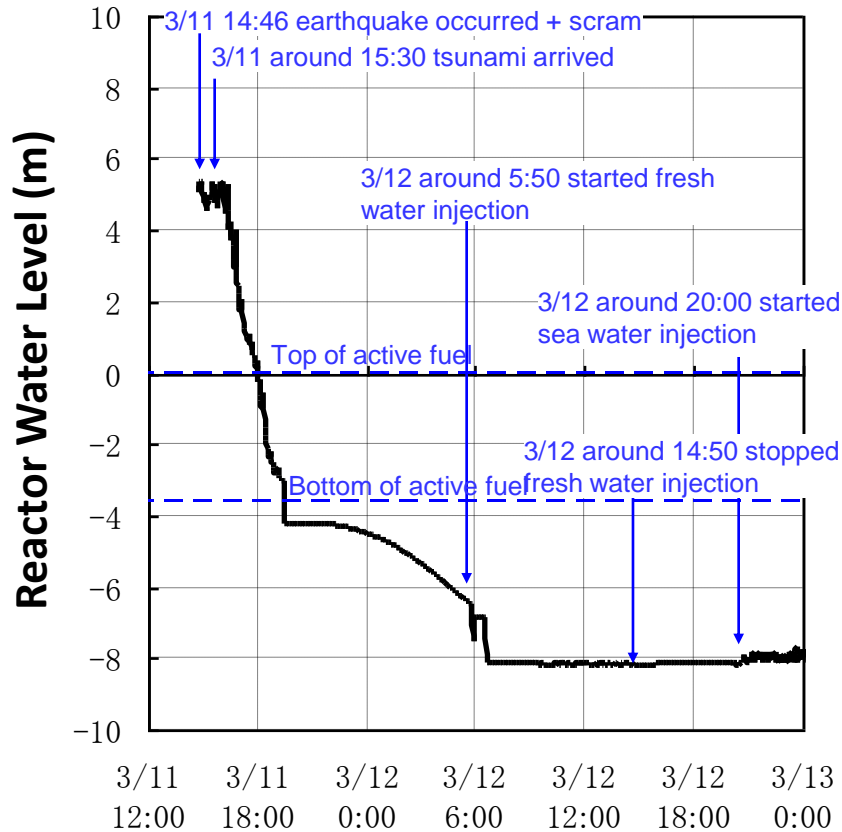

- reached top of active fuel in 3 hours (around 18:00) after the scram
- reached bottom of active fuel in 4 and a half hours (around 19:30) after the scram

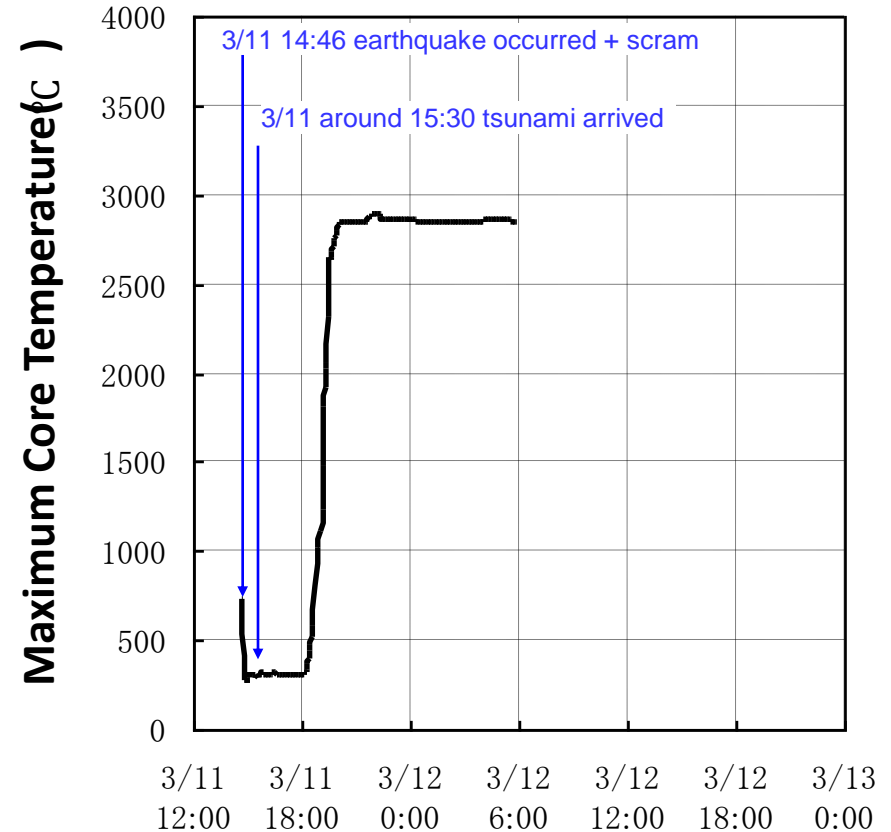

The core temperature started increasing when the reactor water level became lower than top of active fuel, then reached the core melting temperature.

Failure of Power Supply and Cooling Systems

The reactors shut down automatically due to the **Earthquake**, loss of external power supply.

Power supply equipment such as D/Gs was not unavailable due to the **Tsunami**, loss of all AC power supply

Units 1 & 2

Loss of function of DC power supply due to the **Tsunami**

Unit 3

Function of DC power supply maintained

Unit 1

IC was unavailable to check status and operate. HPCI was unavailable to start up.

Unit 2

RCIC continued cooling.

Unit 3

RCIC or HPCI continued cooling until battery ran out.

Led to accident at early time

RCIC continued to operate until 13:25 on March 14.

After RCIC stopped at 11:36 on March 12, HPCI started up automatically due to low level of water in reactor.

Fission Products

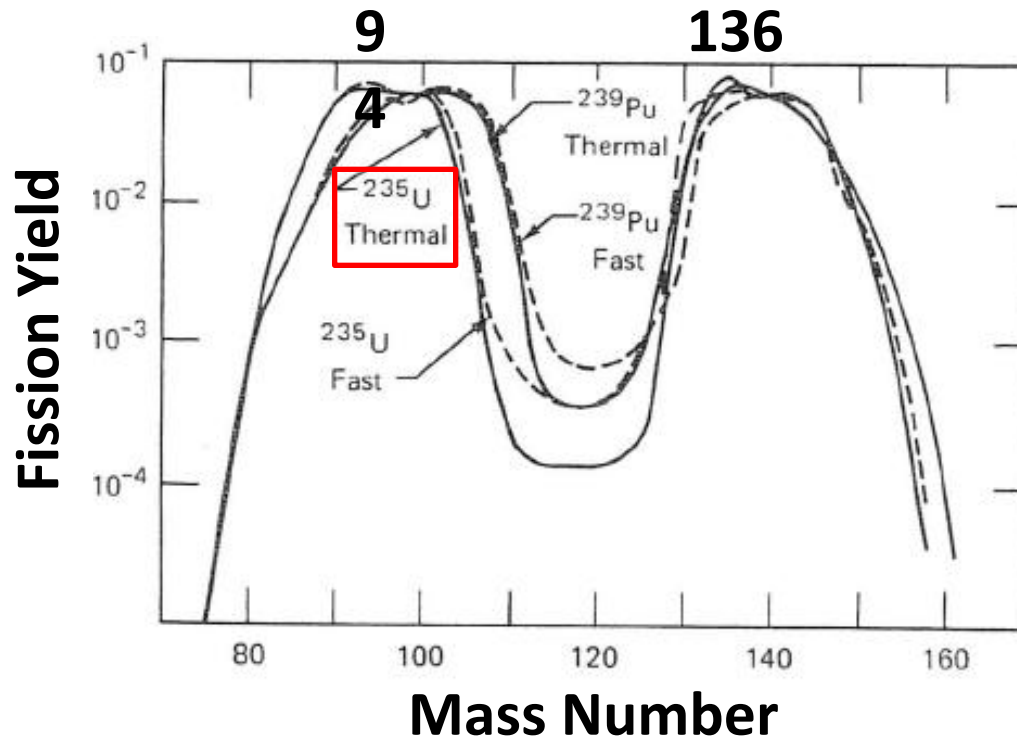

- More than 30 chemical elements are produced by fission reaction
- Chemical state of fuel can evolve substantially during burn-up
- 20-25% of fission products are gas atoms (Kr, Xe)

Groups of Radionuclides from Nuclear Fuel

<i>Group #</i>	<i>Designation</i>	<i>Elements</i>
1	Noble Gases	Xe, Kr
2	Halogens	I, Br
3	Alkali Metals	Cs, Rb
4	Tellurium Group	Te, Sb, Se
5	Barium, Strontium	Ba, Sr
6	Noble Metals	Ru, Rh, Pd, Mo, Tc, Co
7	Lanthanides	La, Zr, Nd, Eu, Nb, Pm, Pr, Sm, Y, Cm, Am
8	Cerium Group	Ce, Pu, Np

Radionuclides considered Important in the Reactor Safety Study Consequence Analysis (1)

3,200 MWth PWR case

Radionuclides	Half-life [days]	Shutdown inventory [MCi]
1) Noble gases		
⁸⁵ Kr*	3950	0.56
^{85m} Kr*	0.183	24
⁸⁷ Kr*	0.0528	47
⁸⁸ Kr*	0.117	68
¹³³ Xe	5.28	170
¹³⁵ Xe	0.384	34
2) Halogens		
¹³¹ I	8.05	85
¹³² I	0.0958	120
¹³³ I	0.875	170
¹³⁴ I	0.0366	190
¹³⁵ I	0.28	150
3) Alkali metals		
¹³⁴ Cs	750	7.5
¹³⁶ Cs	13	3
¹³⁷ Cs	11000	4.7
⁸⁶ Rb*	18.7	0.026

4) Tellurium group		
¹²⁷ Te*	0.391	5.9
^{127m} Te	109	1.1
¹²⁹ Te*	0.048	31
^{129m} Te	0.34	5.3
^{131m} Te	1.25	13
¹³² Te	3.25	120
¹²⁷ Sb	3.88	6.1
¹²⁹ Sb	0.179	33
5) Barium and strontium group		
⁸⁹ Sr	52.1	94
⁹⁰ Sr	11030	3.7
⁹¹ Sr	0.403	110
¹⁴⁰ Ba	12.8	160

*** Indicates negligible contribution to health effects**

Radionuclides considered Important in the Reactor Safety Study Consequence Analysis (2)

Radionuclides	Half-life [days]	Shutdown inventory [MCi]
6) Noble metals		
⁵⁸ Co*	71	0.78
⁶⁰ Co*	1920	0.29
⁹⁹ Mo	2.8	160
^{99m} Tc*	0.25	140
¹⁰³ Ru	39.5	110
¹⁰⁵ Ru*	0.185	72
¹⁰⁶ Ru	366	25
¹⁰⁵ Rh*	1.5	49

7+8) Lanthanides and cerium group		
⁹⁰ Y*	2.67	3.9
⁹¹ Y	59	120
⁹⁵ Zr	65.2	150
⁹⁷ Zr	0.71	150
⁹⁵ Nb	35	150
¹⁴⁰ La	1.67	160
¹⁴¹ Ce	32.3	150
¹⁴³ Ce*	1.38	130
¹⁴⁴ Ce	284	85
¹⁴³ Pr	13.7	130
¹⁴⁷ Nd*	11.1	60
²³⁹ Np	2.35	1640
²³⁸ Pu	32500	0.057
²³⁹ Pu	8.90E+06	0.021
²⁴⁰ Pu	2.40E+06	0.021
²⁴¹ Pu	5350	3.4
²⁴¹ Am*	1.50E+05	0.0017
²⁴² Cm	163	0.5
²⁴⁴ Cm	6630	0.023

3,200 MWth PWR case

*** Indicates negligible contribution**

Examples of Decay Chains containing Cs from Fission Reaction of ^{235}U by Thermal Neutrons

133

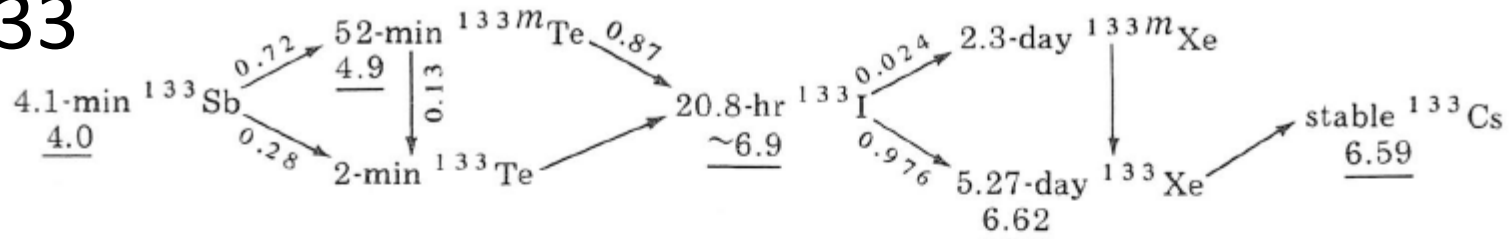

135

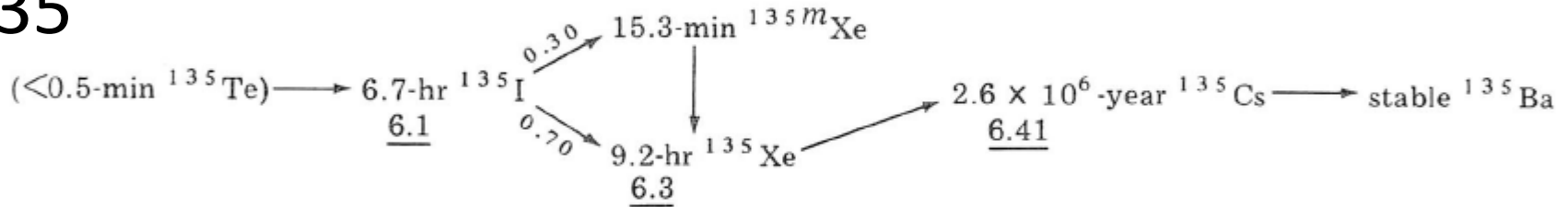

137

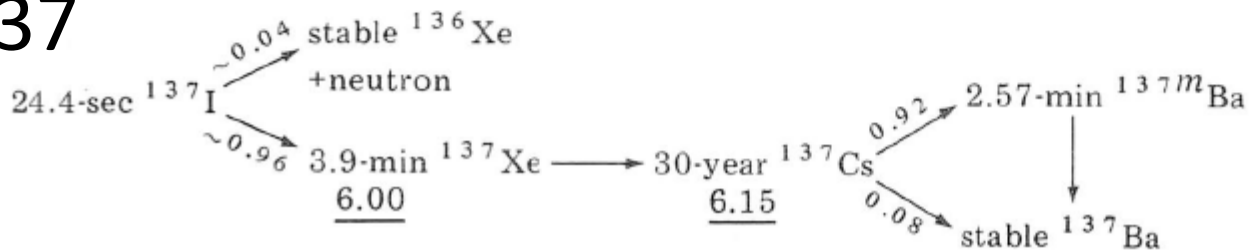

Fission Gas Yield

Isotopes	²³⁵ U	²³⁹ Pu
⁸³ Kr	0.40	0.30
⁸⁴ Kr	0.85	0.50
⁸⁵ Kr	0.15	0.13
⁸⁶ Kr	1.40	0.80
Total Kr	2.8	1.7
¹³¹ Xe	3.2	3.8
¹³² Xe	4.7	5.3
¹³⁴ Xe	6.6	7.5
¹³⁶ Xe	5.9	6.6
Total Xe	20.4	23.2

- Minor actinides (Am, Cm) also produce significant quantities of He during further irradiation by (n,α) reaction

Tsunami on March 11, 2011



Source: TEPCO